

※ W/ SUN ROOF

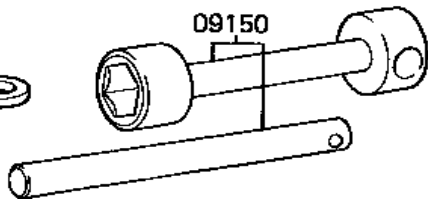

22R#

11400

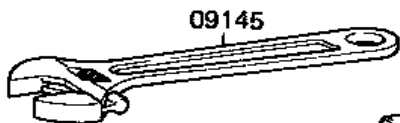
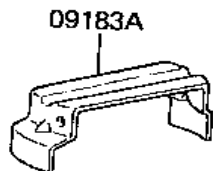
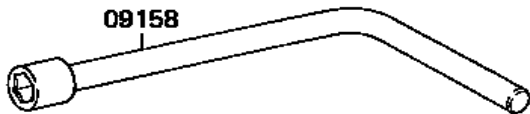
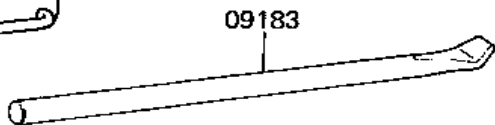
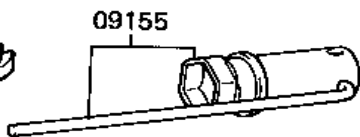
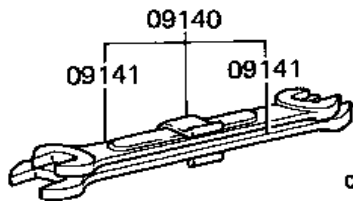
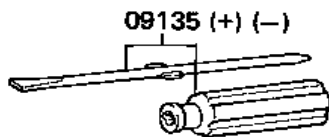
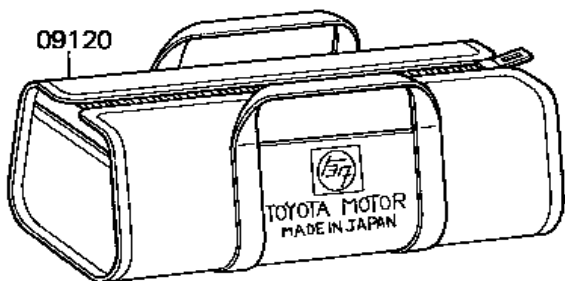
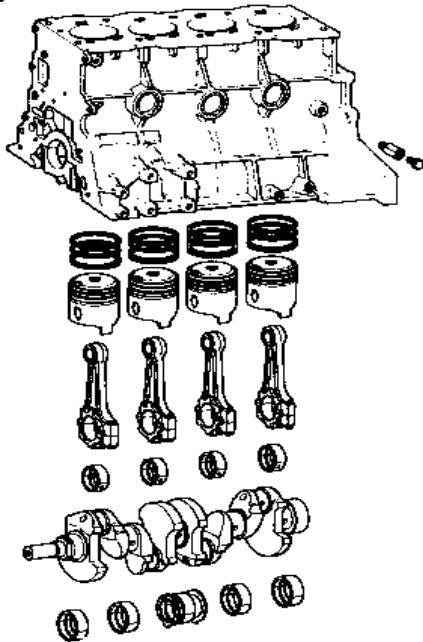

2L#

11400

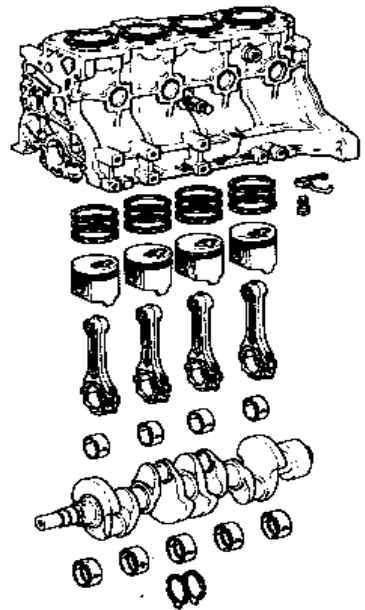

3B, 13BT

11400

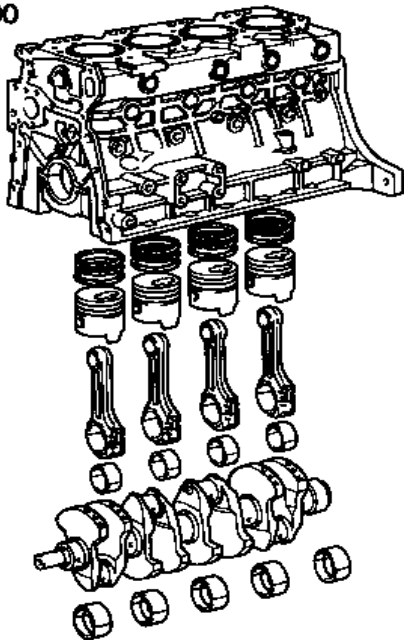

22R#

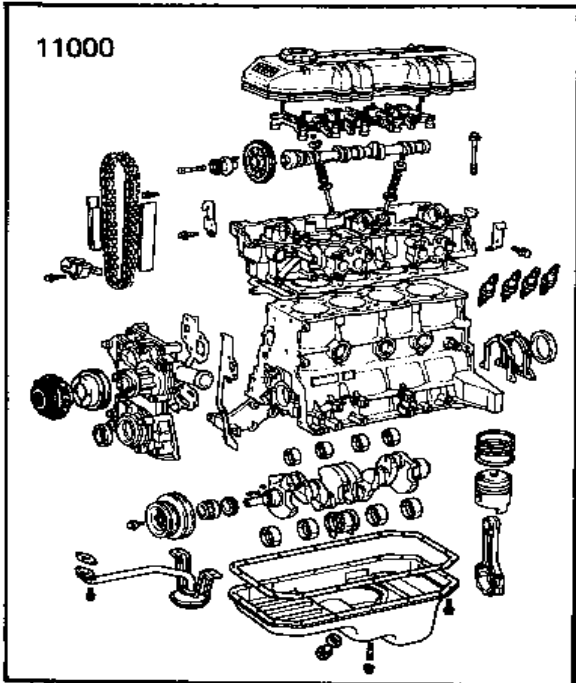

2L#

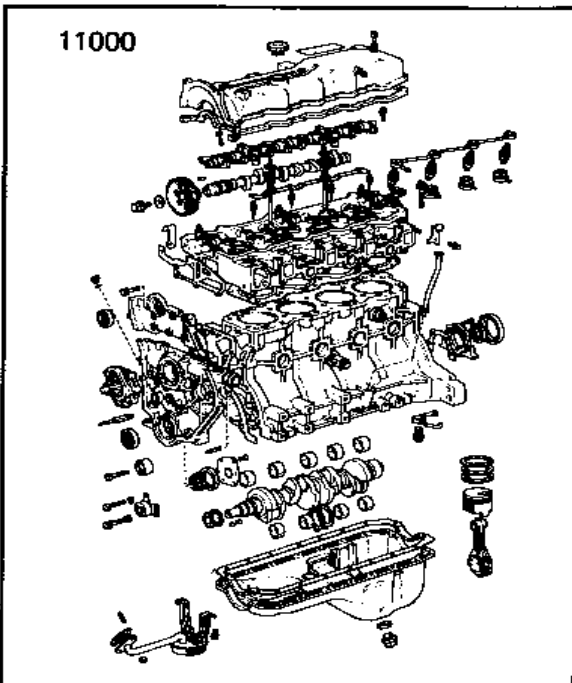

3B, 13BT

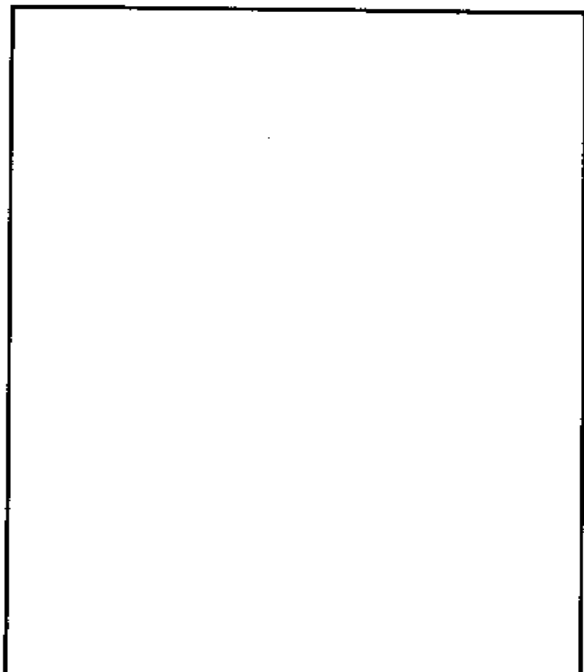
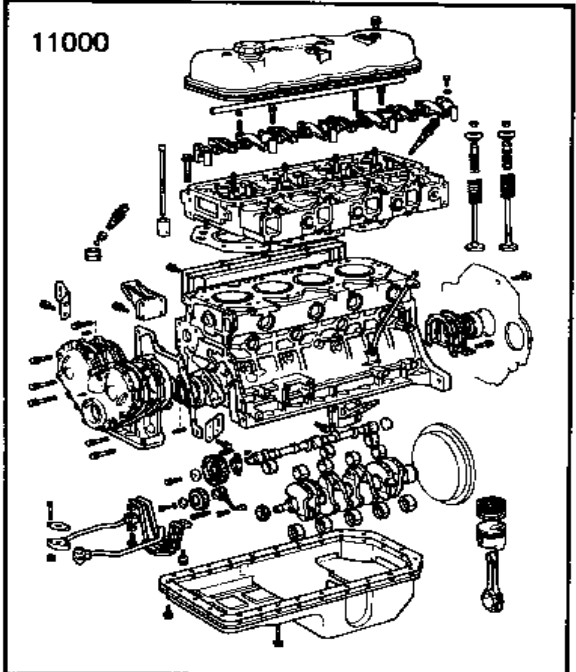

04111

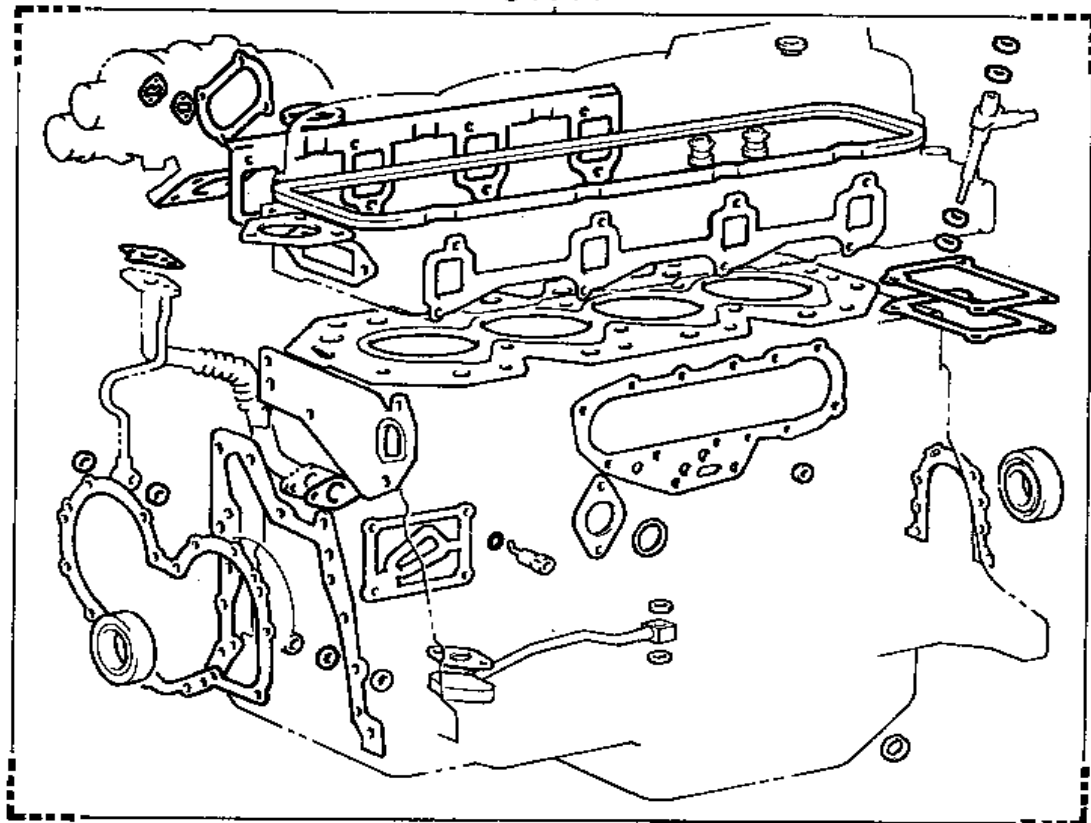

04112

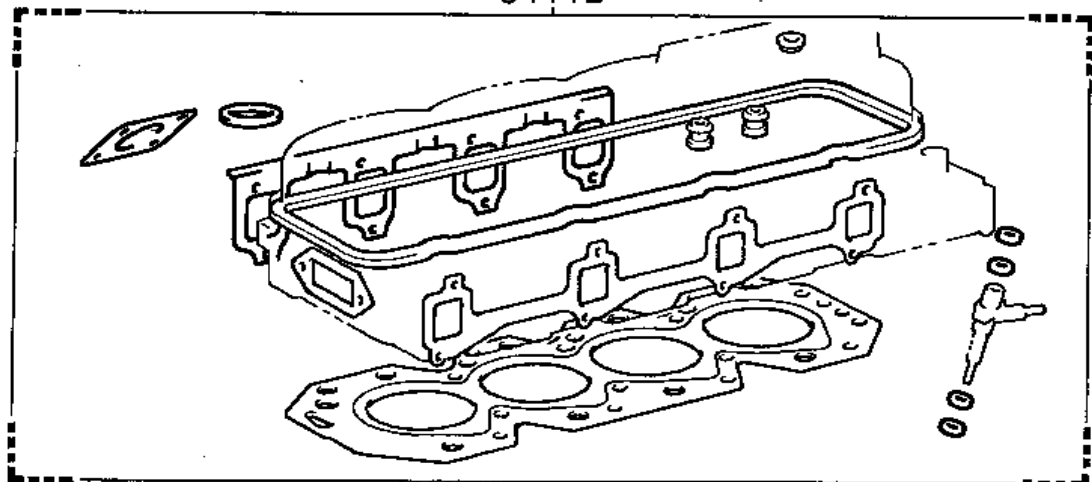

MA 7753-A

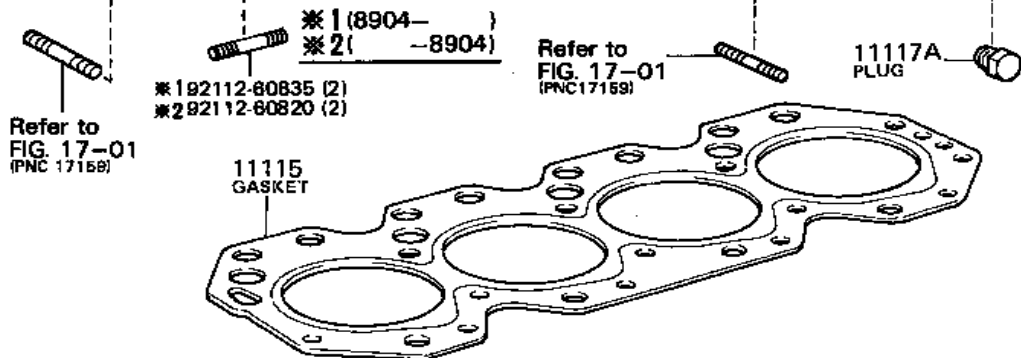
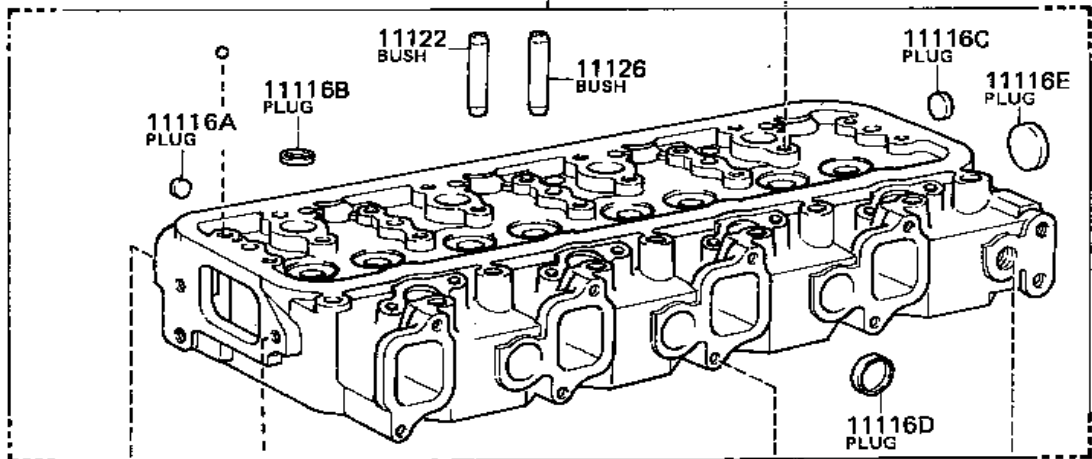
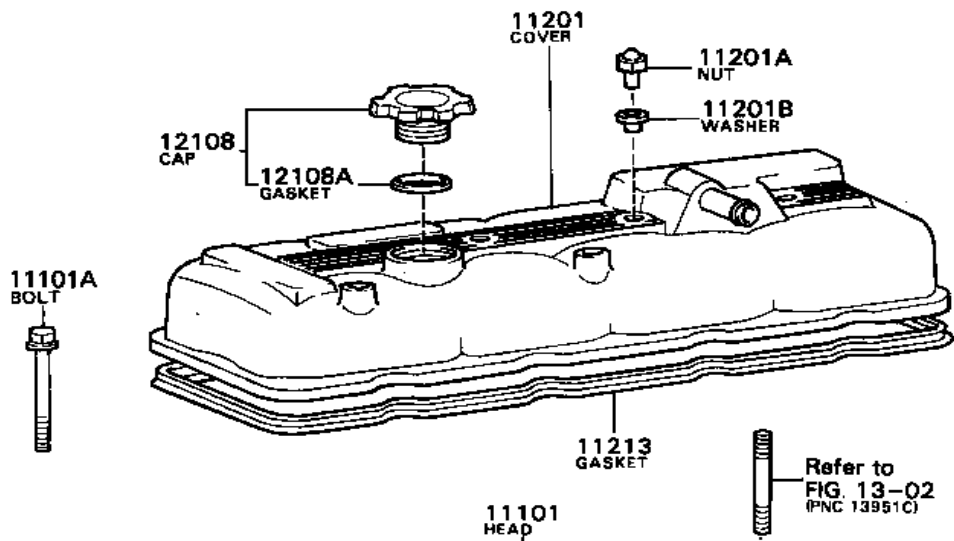

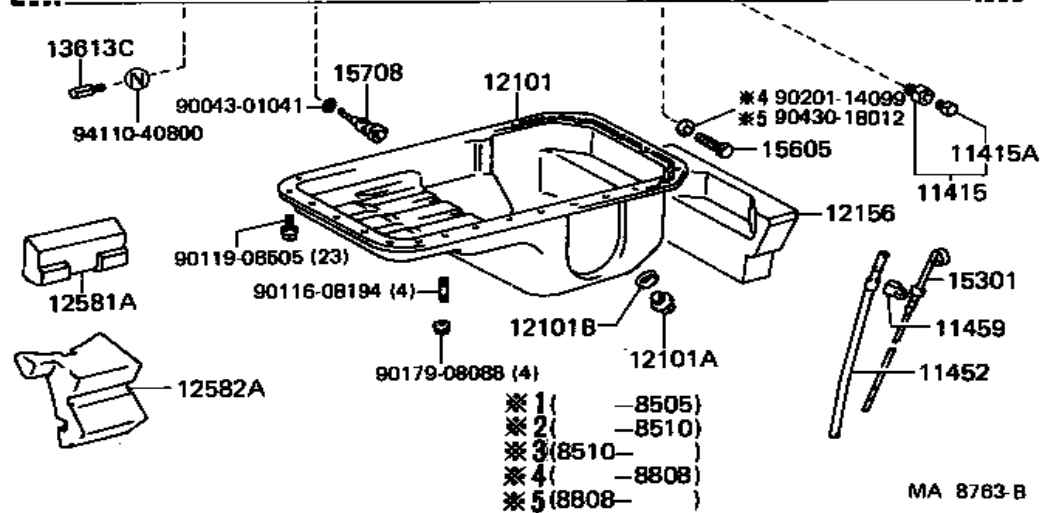
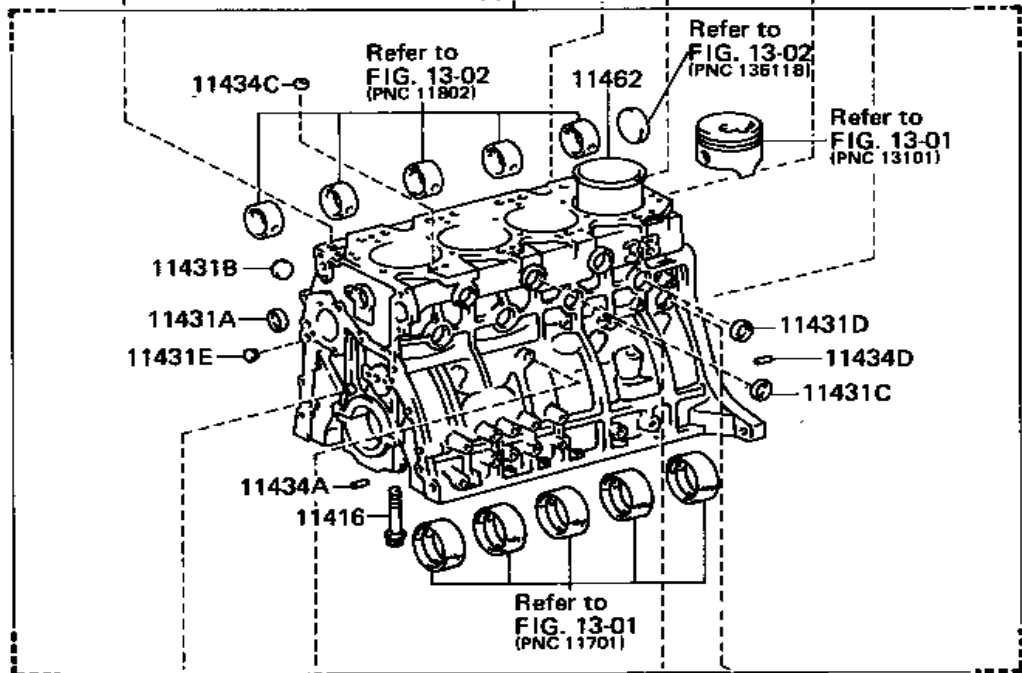
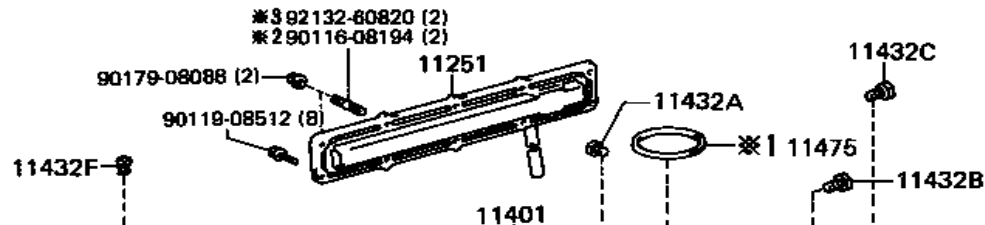

91611-61016 (2)

11301
CASE

11346
BEARING

Refer to
FIG. 15-01

11301A
PIN
*3 11302C 11328
GASKET
*3
11302C

11391
POINTER

11302A
SEAL

11302
COVER

*1 11348
SPACER

11301B
BOLT

11312
GASKET

*1 13BT
*2 (8910 -) 3B

91611-60814 (1)

11355
PLATE

11383
GASKET

11381
RETAINER



11381A
SEAL

91611-61018 (2)

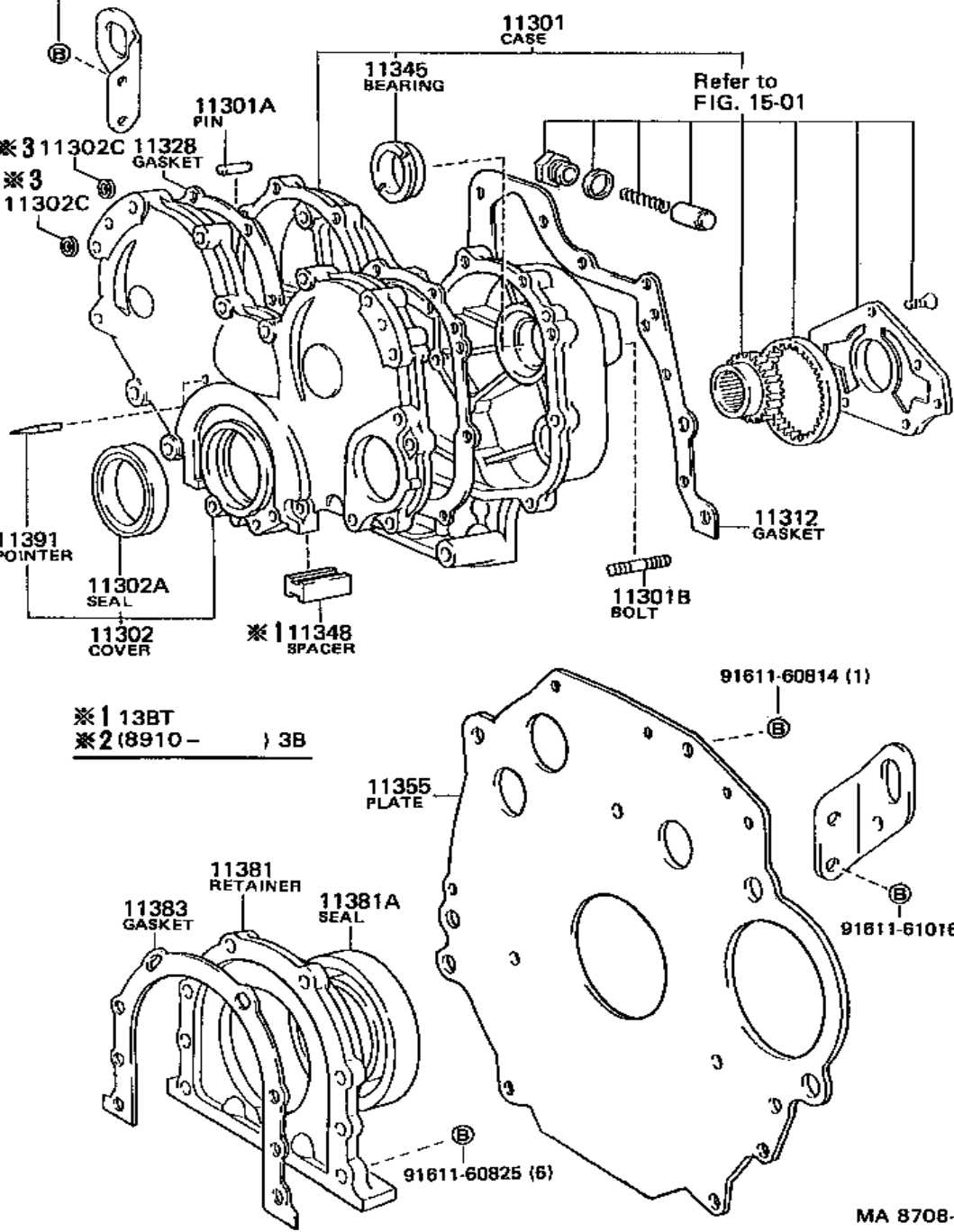
91611-60825 (6)

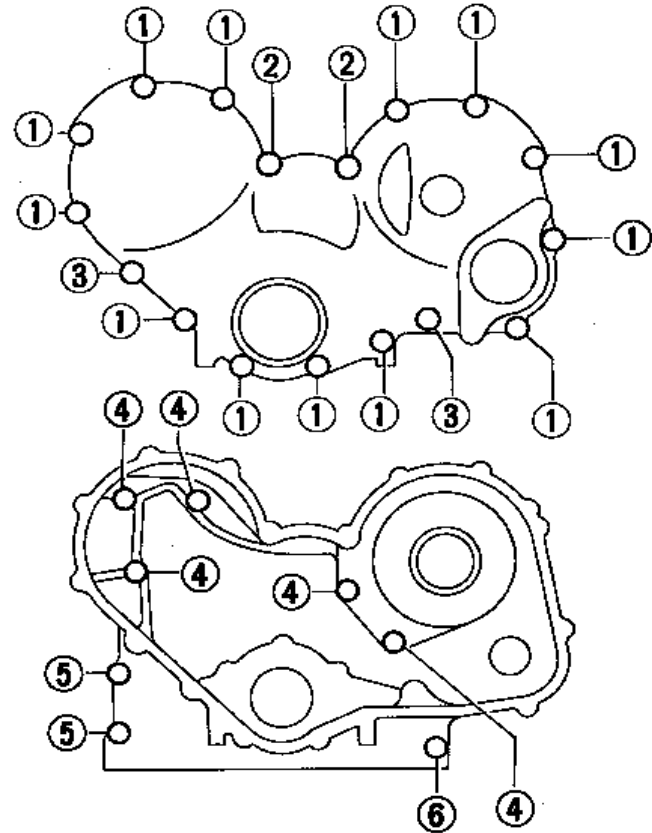



①	ⓐ	91611-60835 (13)
②		90119-08145 (2)
③		90119-10073 (2)

④	ⓐ	91611-60825 (5)
⑤	ⓐ	91611-61060 (2)
⑥		90119-10073 (1)

MA 8694

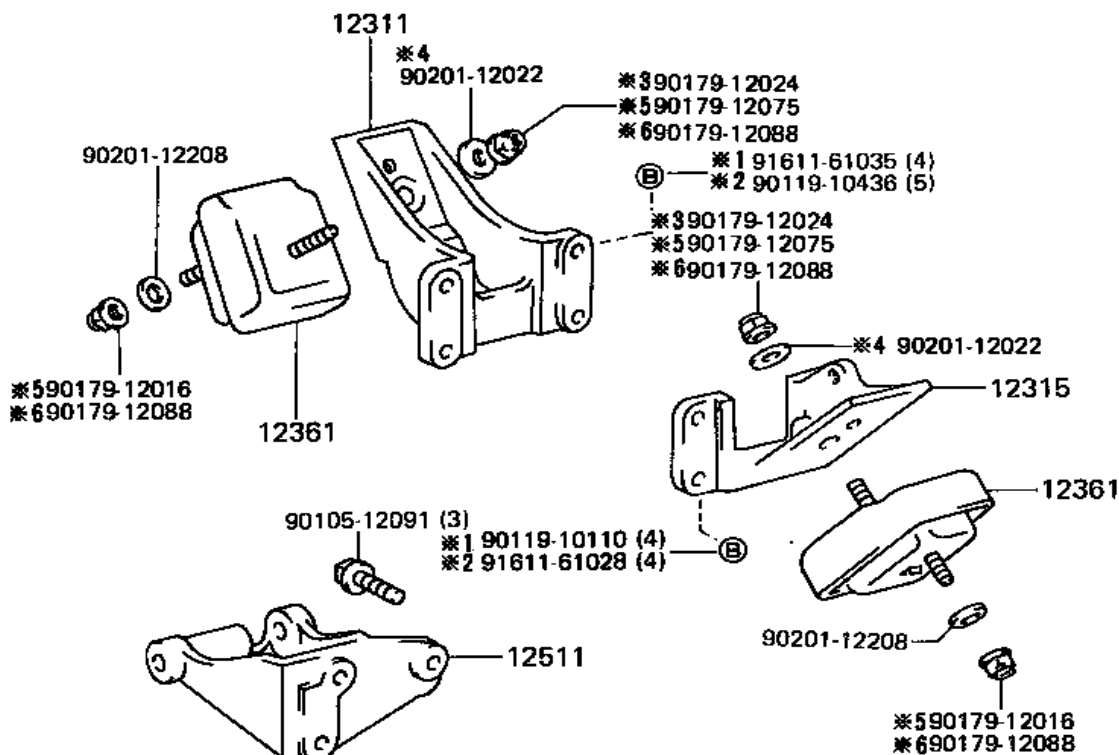

- *1 (-8510)
- *2 (8510-)
- *3 (-8808)
- *4 (8808-)
- *5 (8808-8812)
- *6 (8812-)
- *7 (-8901)
- *8 (8901-)

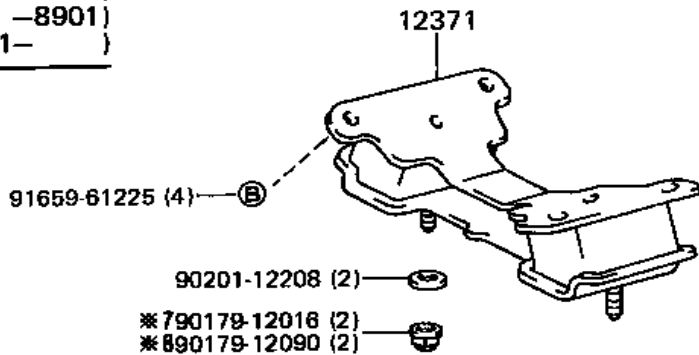

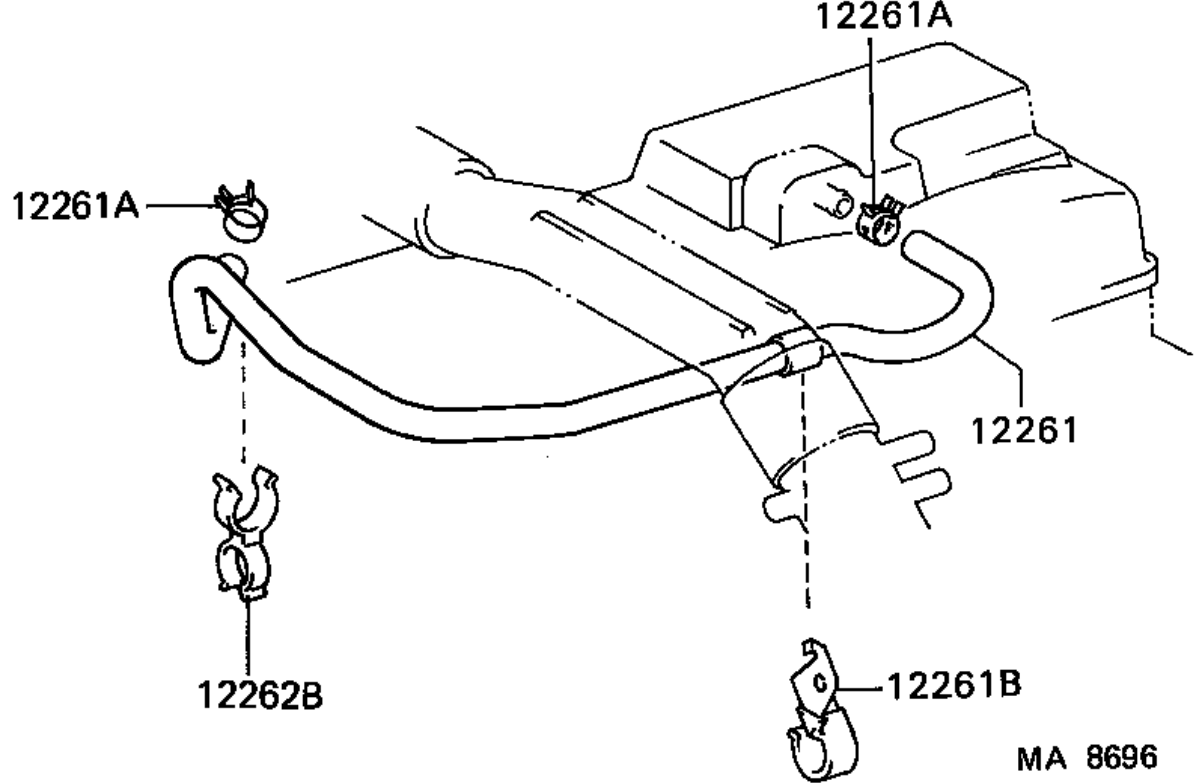

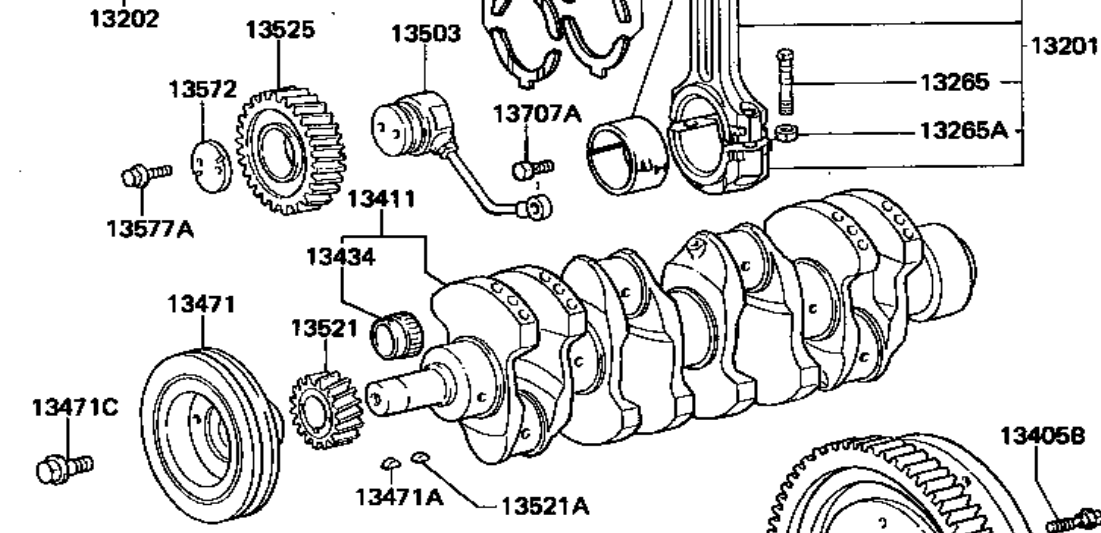
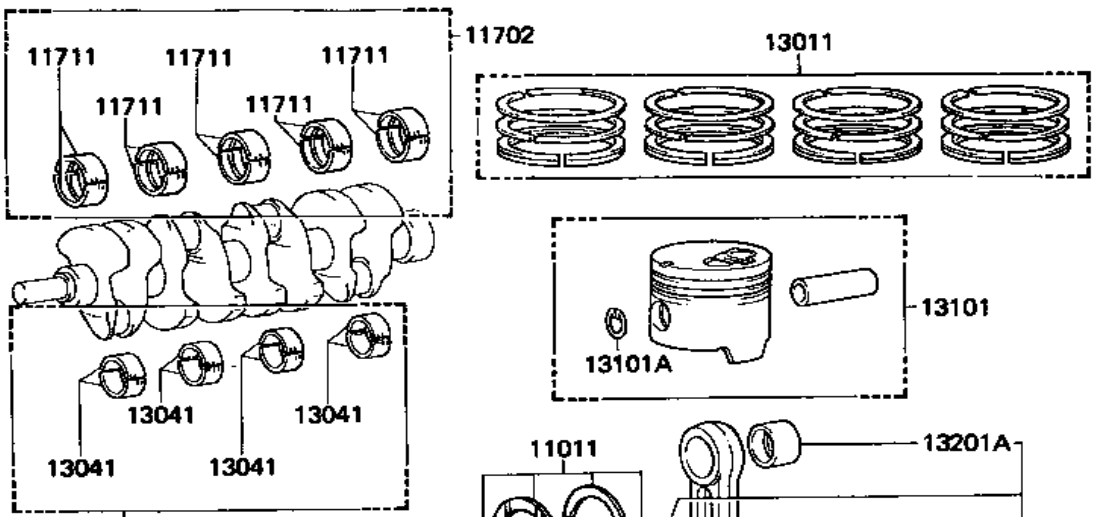

W/ PS (8608-) W/ COOLER

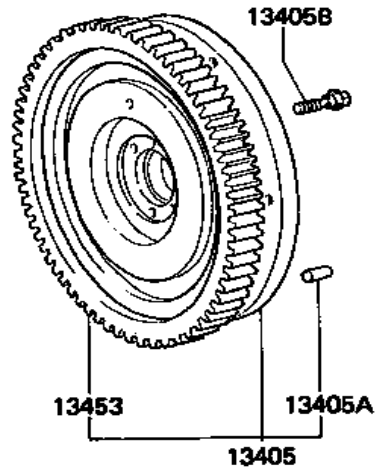
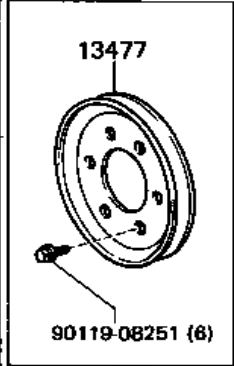
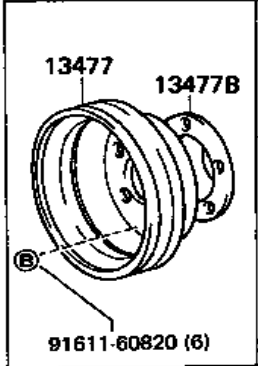

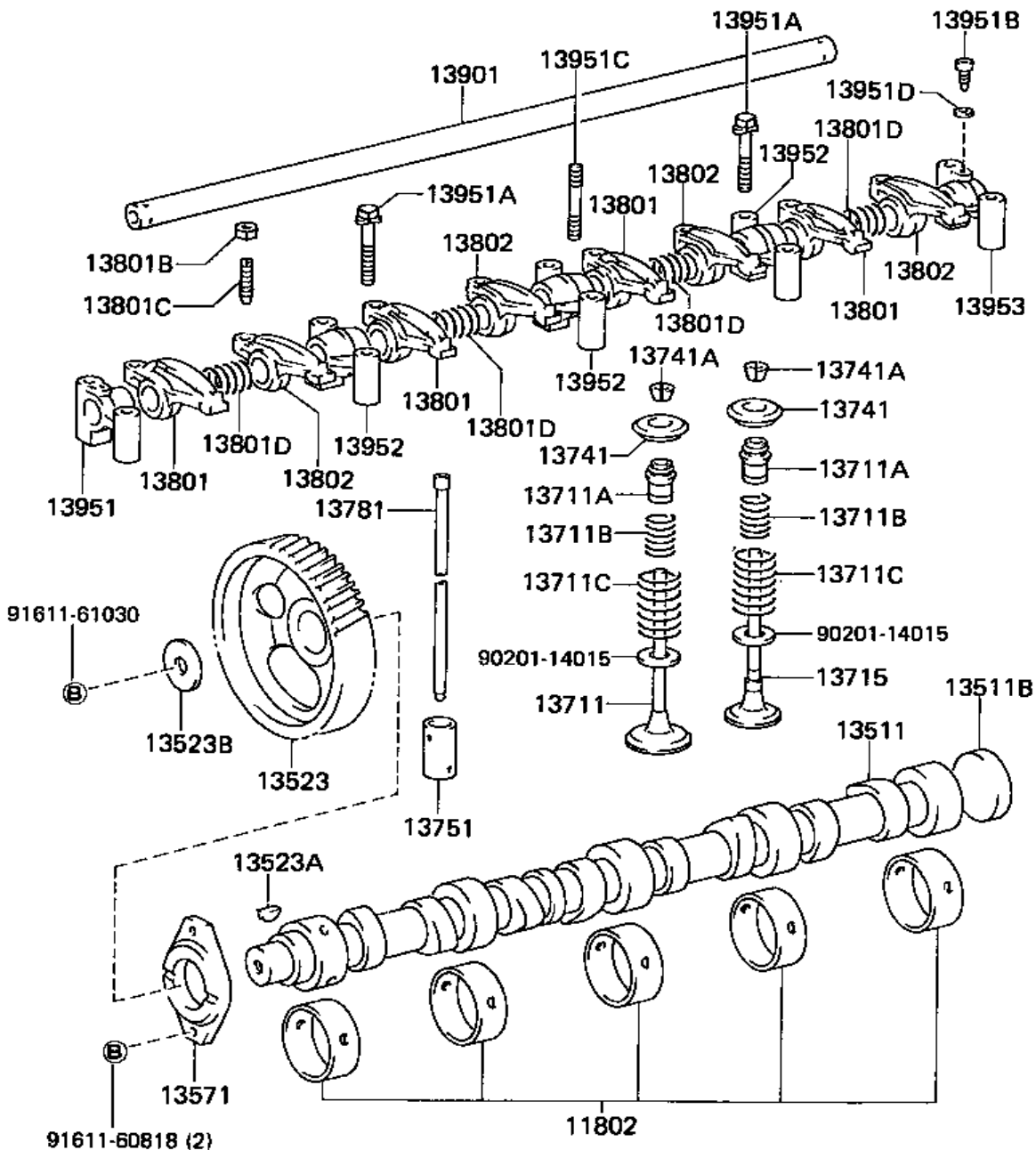

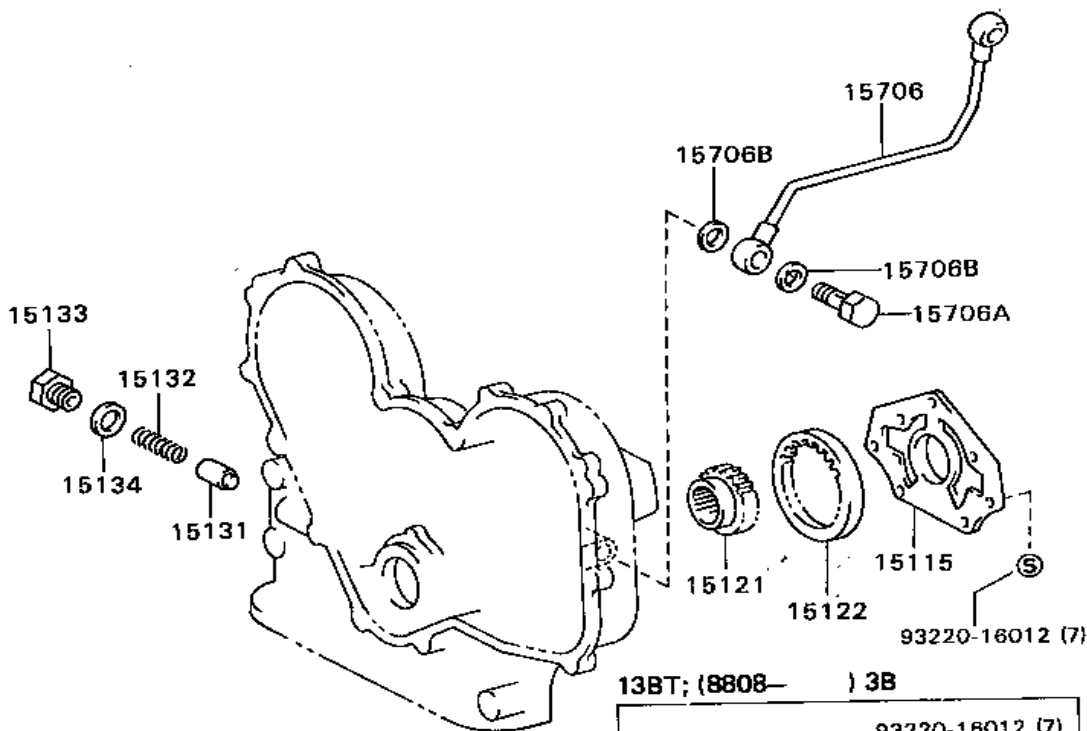

13BT; (8808-) 3B

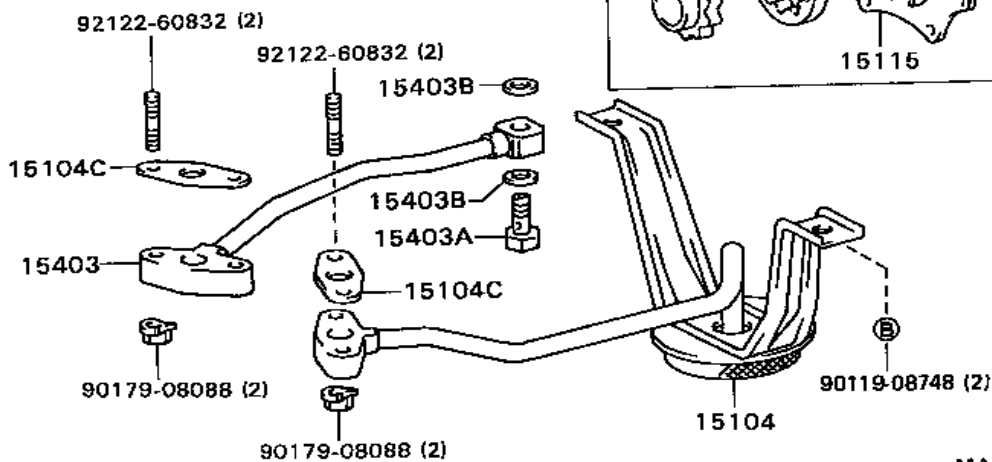
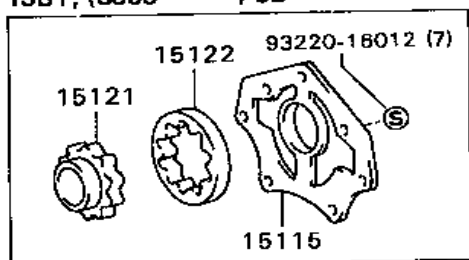

MA 8705-B

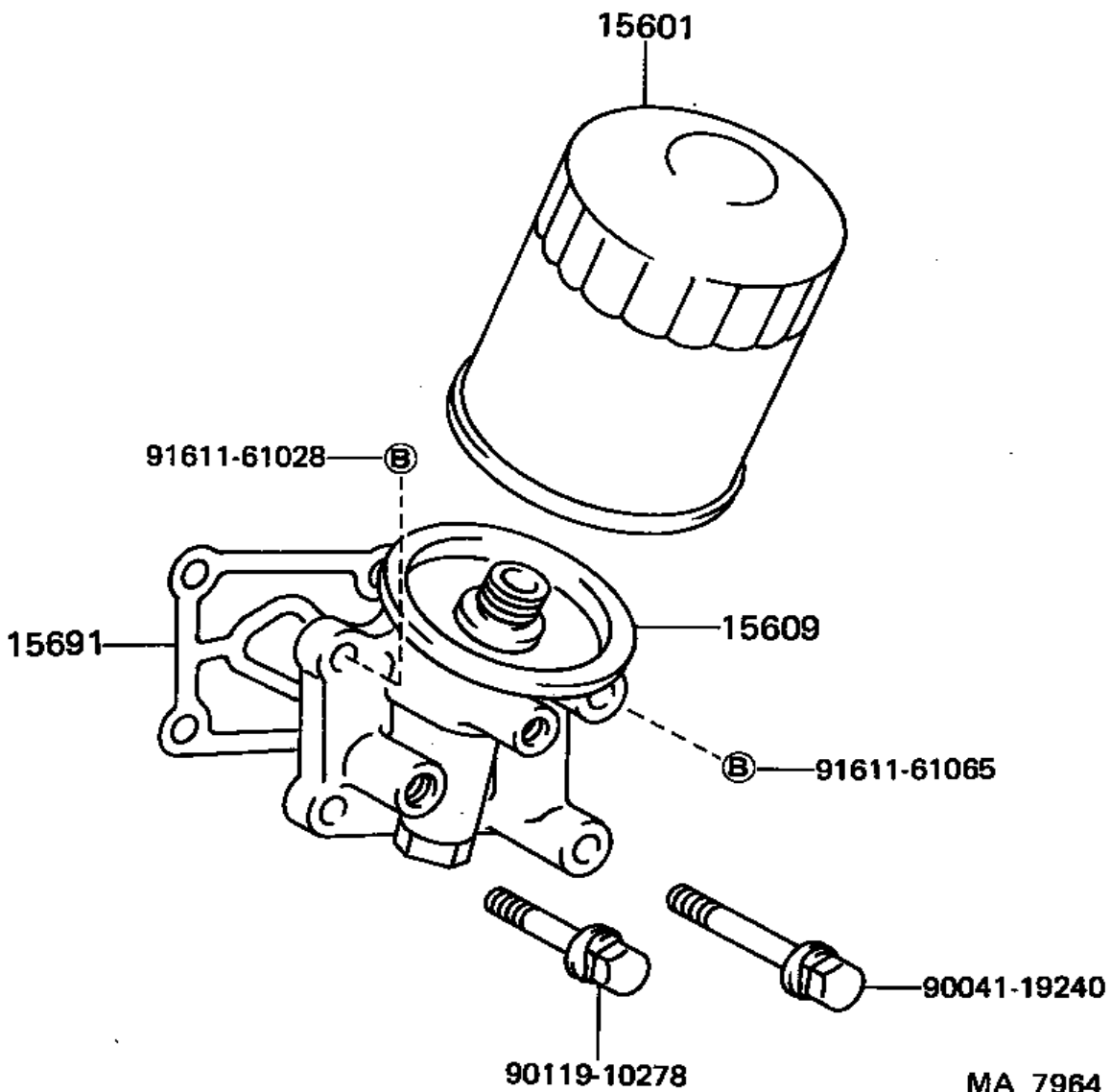

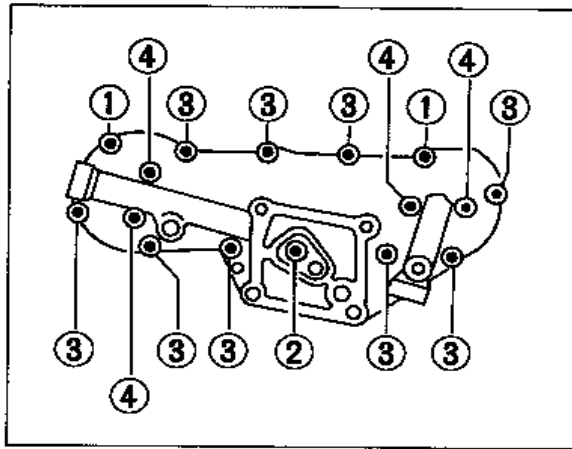

①		90179-08088 (2)
		92122-60828 (2)
②		90110-08004
		94531-00800
③		91611-60835 (9)
		90179-08088 (4)
④		

※1 (-8704)
 ※2 (8704-)

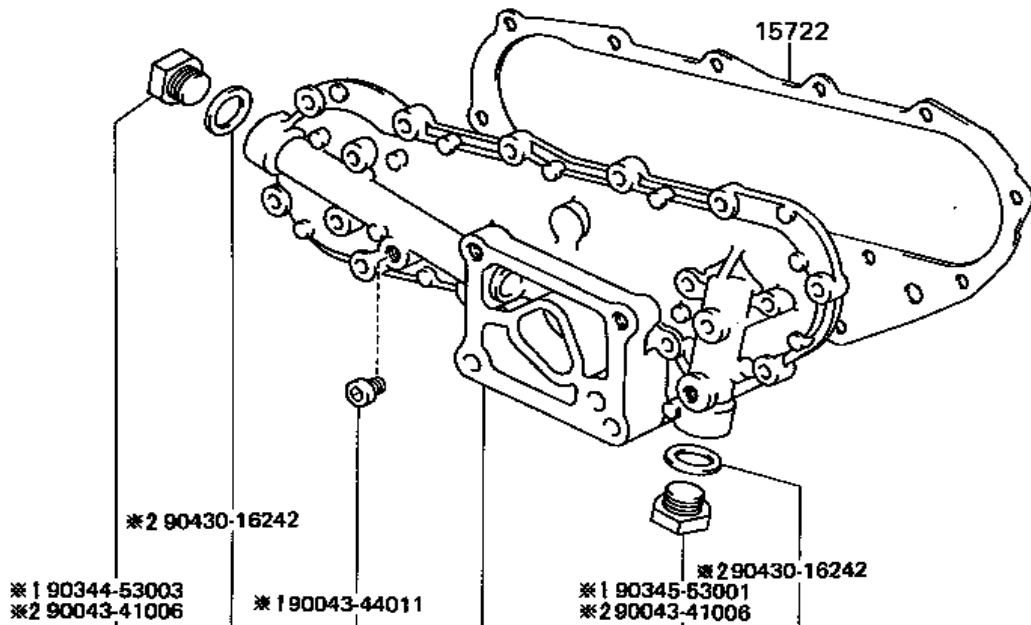
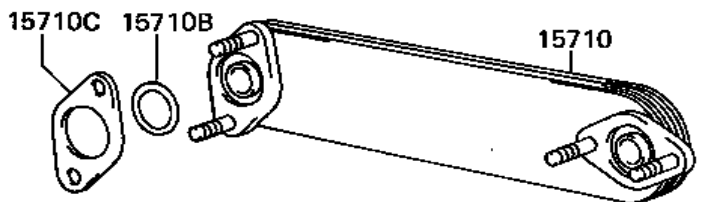

15791

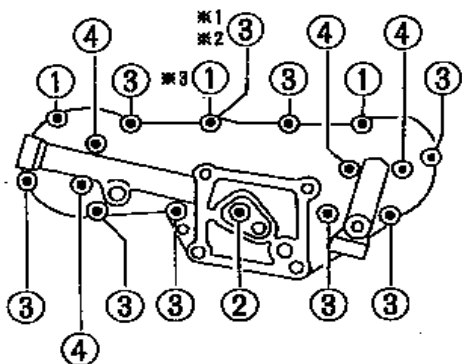

①		90179-08088*2(2), *3(3)
		92122-60828*2(2), *3(3)
②		90110-08004
		94631-00800
③		*191521-60830 (9)
		91611-60835*2(9), *3(8)
④		91611-60835

※1(8808-8904)
 ※2(8904-8912)
 ※3(8912-)

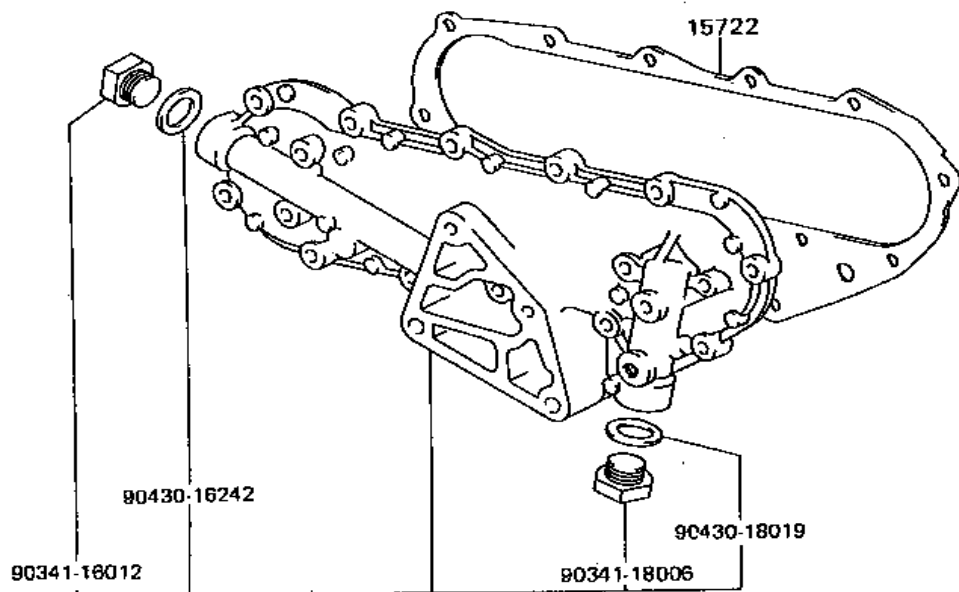
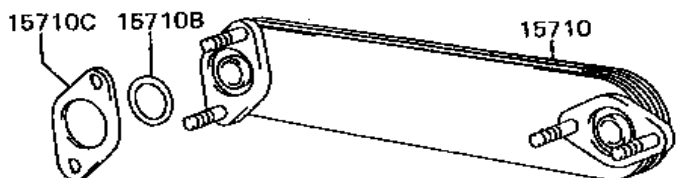

15791

MA B258-B

TEMPERED TYPE

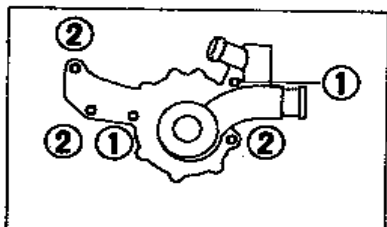
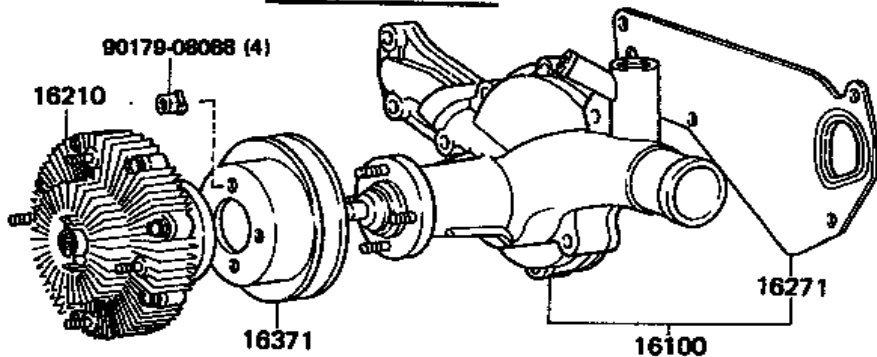

①		90119-08273 (2)
②		90119-08272 (3)

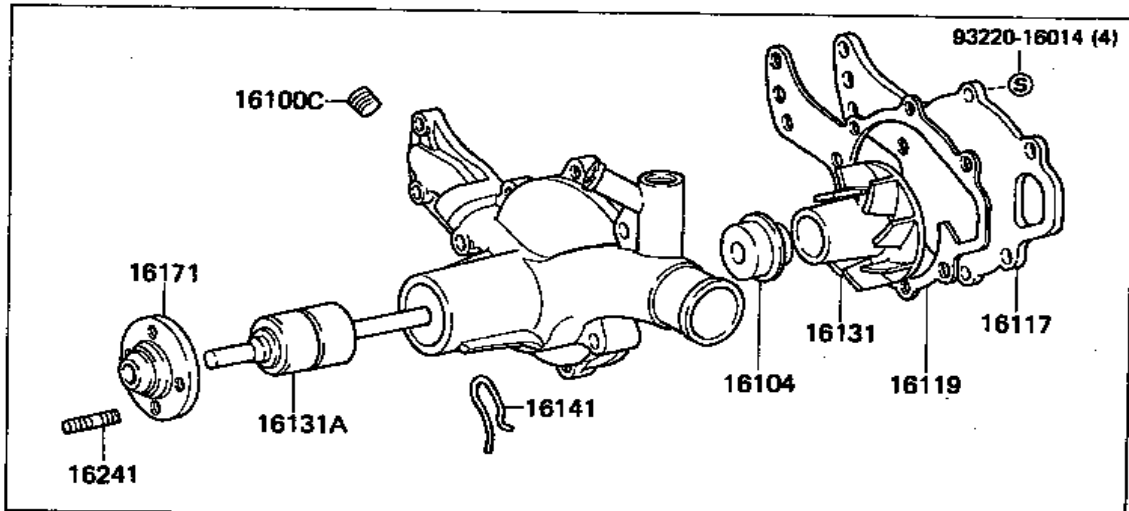
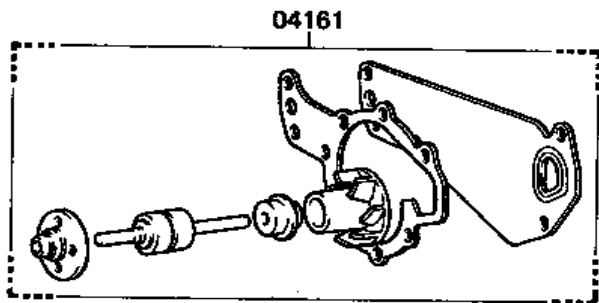

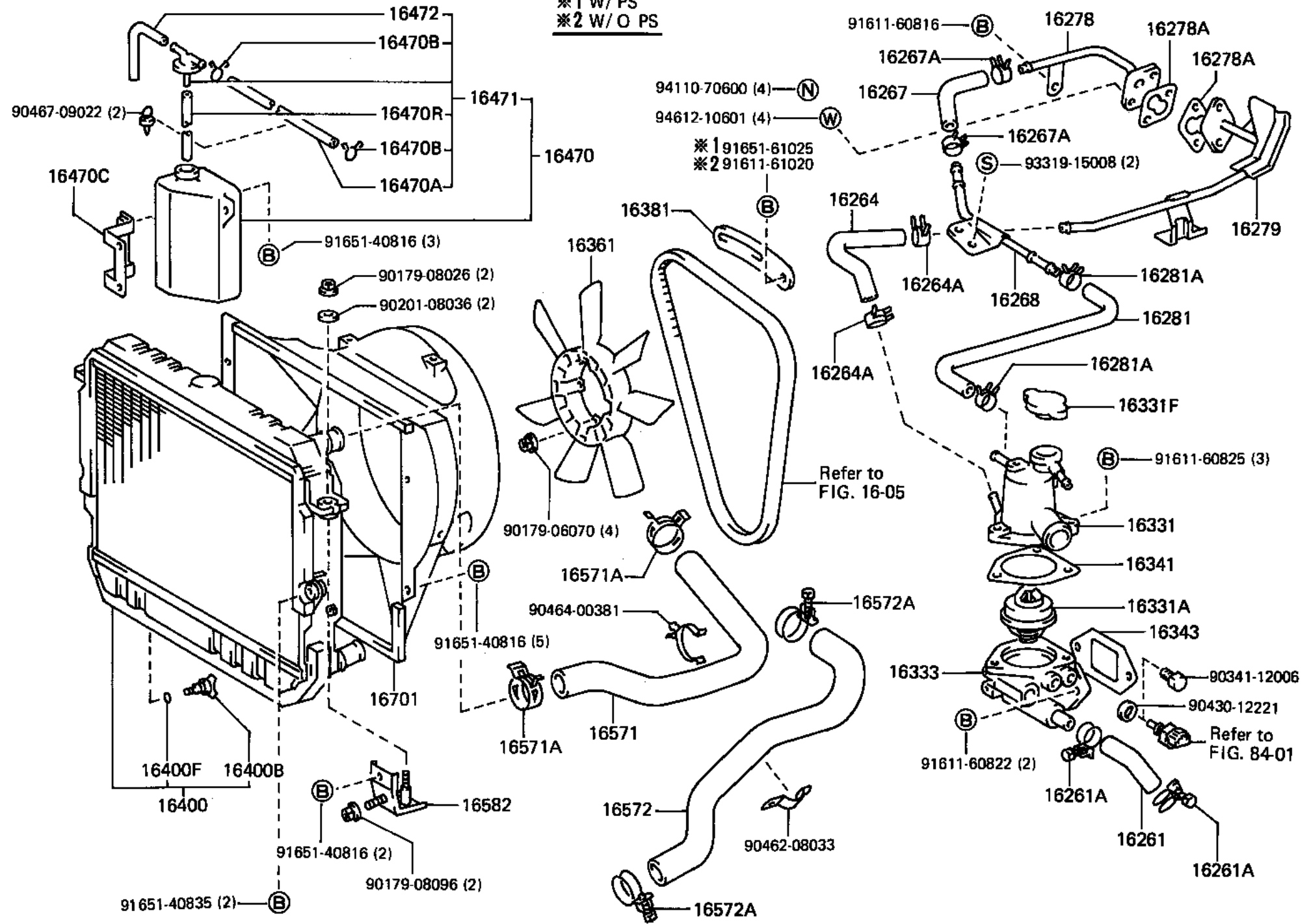

※1 W/ PS
 ※2 W/ O PS



IP : Idle Pulley
 VP : Vane Pump
 WP : Water Pump
 AL : Alternator
 CK : Crankshaft
 CC : Cooler Compressor

AP : Air Pump

	PNC		
	16361A		
	44310A		
	88310A		

22R#

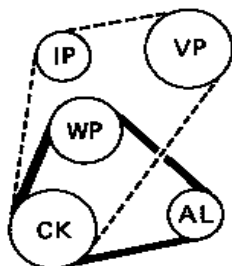

2L, 2LT

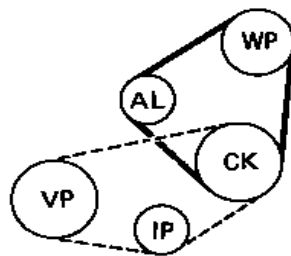

3B, 13BT

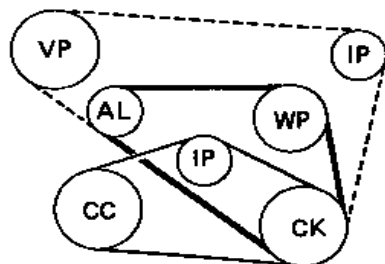

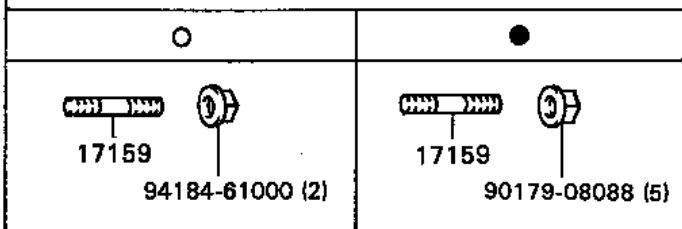
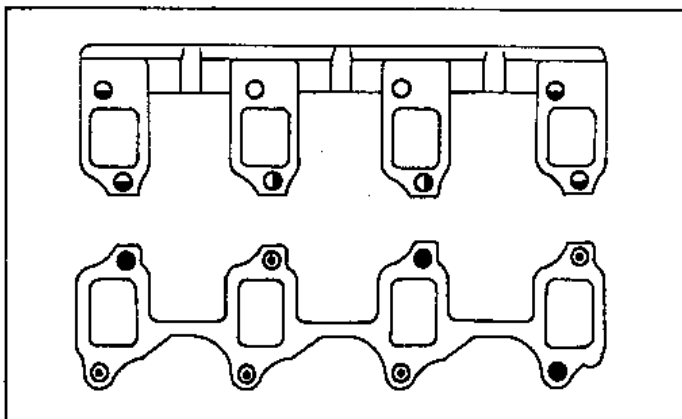
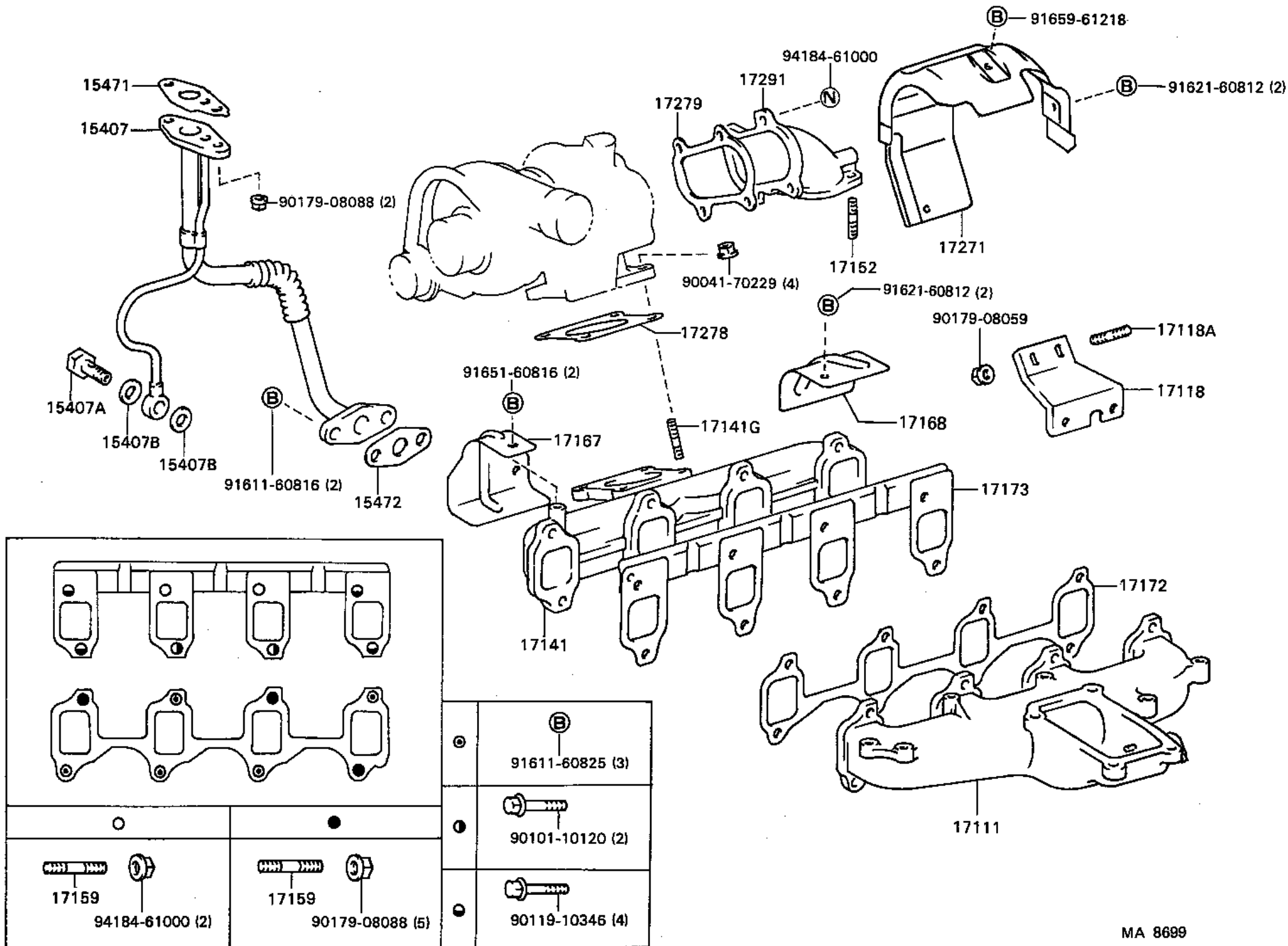

●	ⓑ	91611-60825 (3)
●	ⓐ	90101-10120 (2)
●	ⓐ	90119-10346 (4)

17201

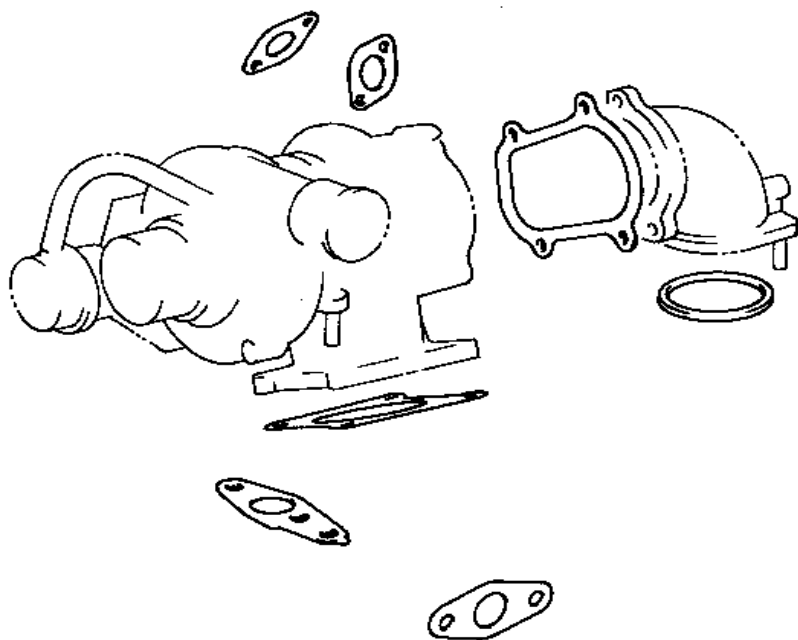
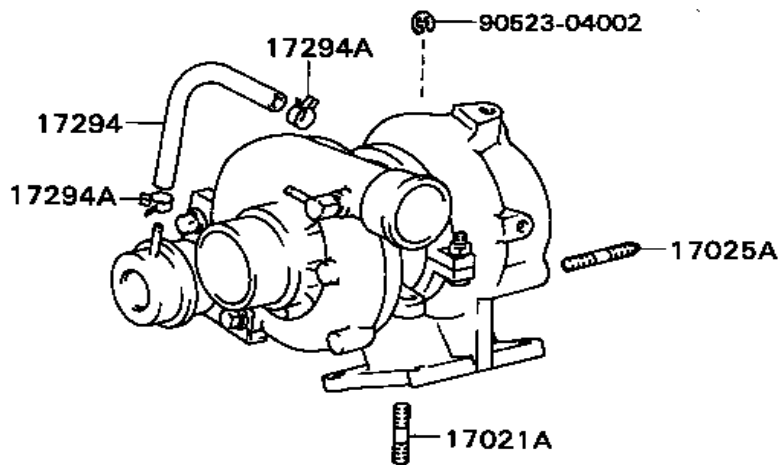

04175

MA 7739-B

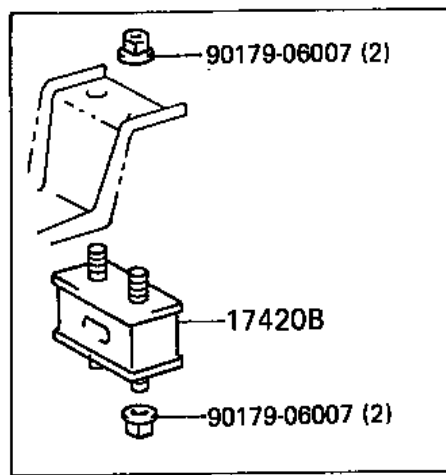

①

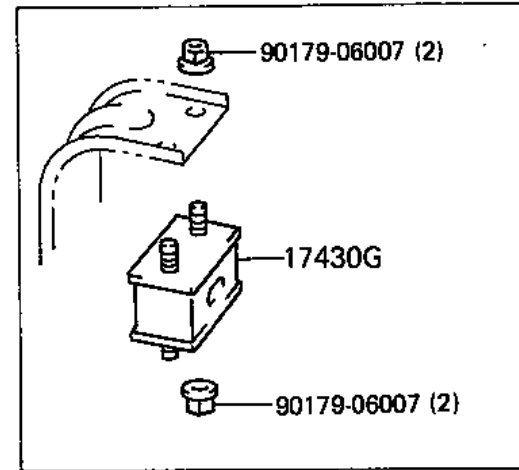

②

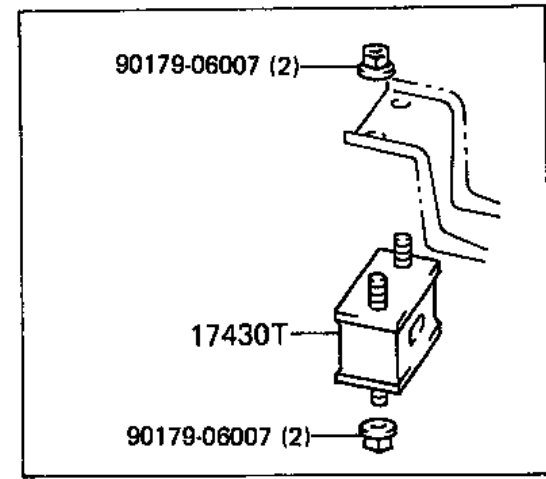

③

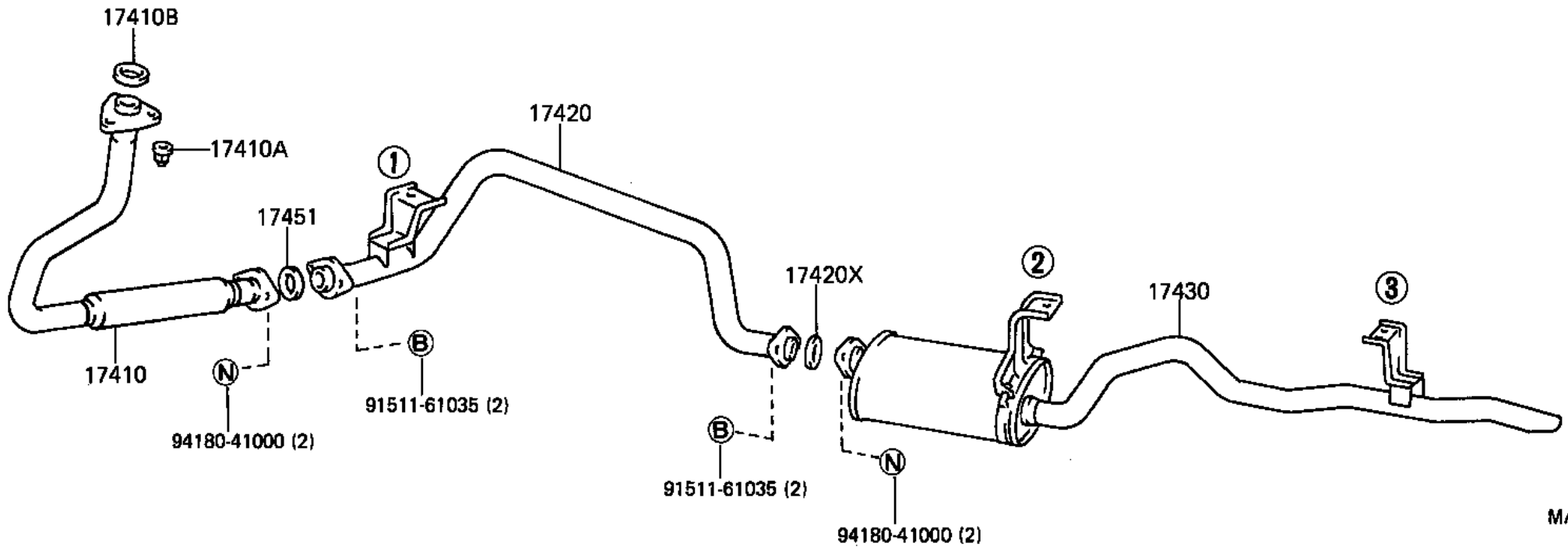

17700

17700A

17705

17845

17841

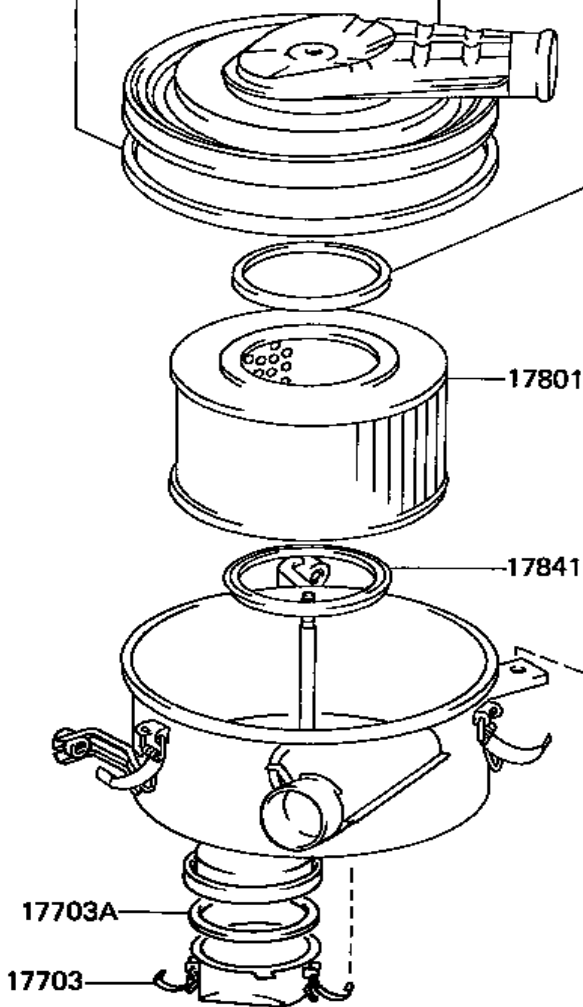

90179-08096

90119-08171 (2)

MA 8700-A

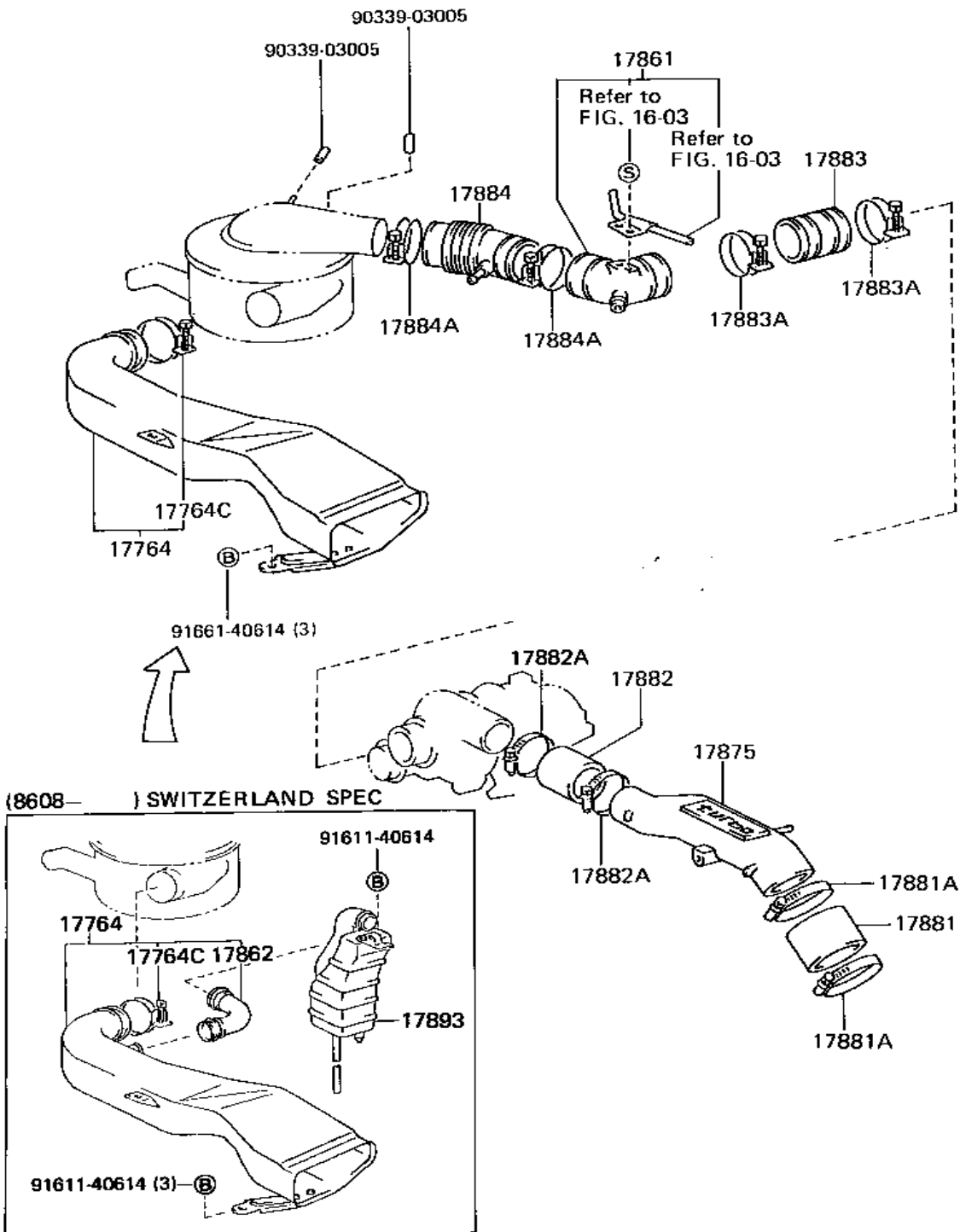

Vacuum Hose Supply Method

Supply of Vacuum Hose is determined in length specified below.

Necessary Length	Part Number	Length available
Below 300 mm	90999-92002	300 mm
301 to 600 mm	90999-92003	600 mm
601 to 950 mm	90999-92004	950 mm
951 to 1300 mm	90999-92006	1300 mm
1301 to 1650 mm	90999-92007	1650 mm
1651 to 2600 mm	90999-92008	2600 mm

1. Actual replacement to vehicle could be made by cutting the hose into desired length.
2. Unlike the vacuum hose already installed in the vehicle, this replacement vacuum hose does not have the hose number printed on it. Accordingly, before installing this vacuum hose, write on it the same hose number as that written on the vacuum hose to be removed as shown below.

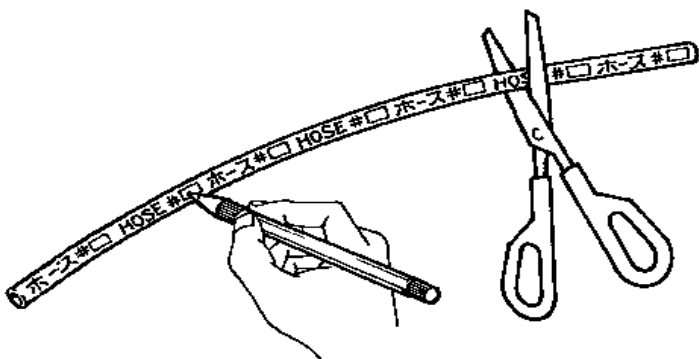
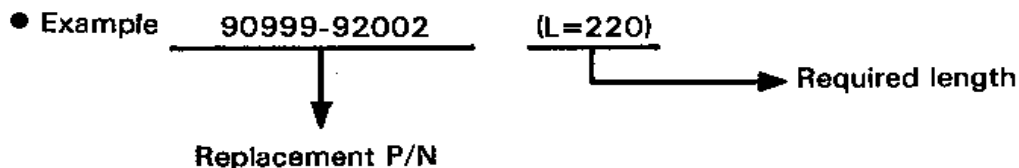

1. As hose is supplied in 300 mm length, cut off excess to meet desired length of 220 mm.
2. Using an oil-based marking pen or a ball-point pen, write the hose number at both ends of the hose, in accordance with the original hose number.

※ | W/ PS

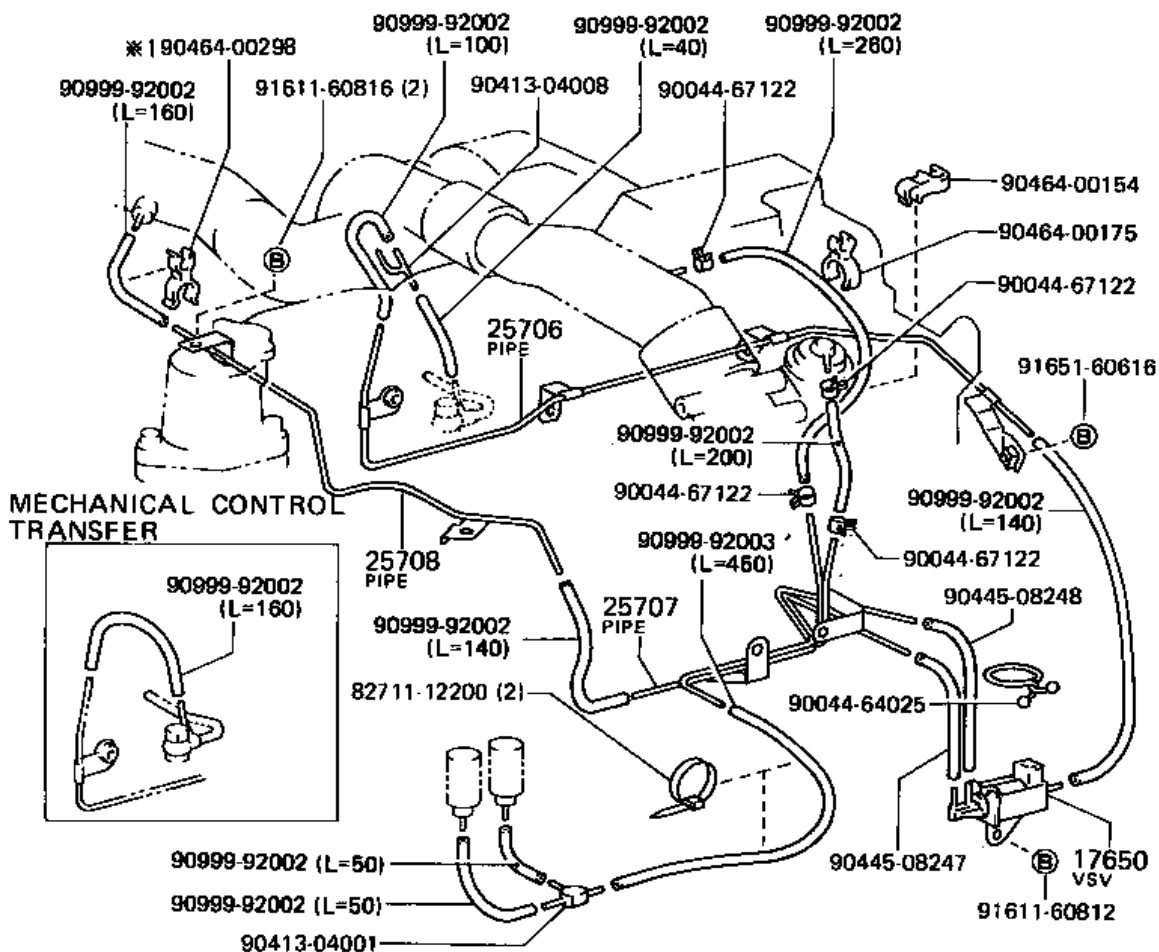

MA 8765-B

11283
PLATE

CAUTION FOR TURBOCHARGED ENGINE

11284



11291
PLATE

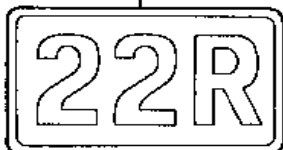

11293
PLATE



17792
PLATE

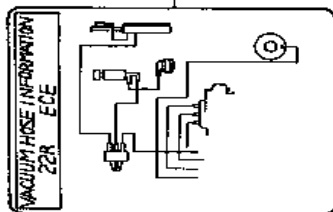

11293A
PLATE

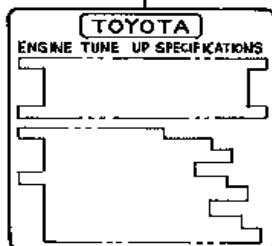

17700C
PLATE



11294

NOTICE DO NOT FILL ENGINE OIL ABOVE "F" LEVEL.

HINWEIS

NOTICE

11298

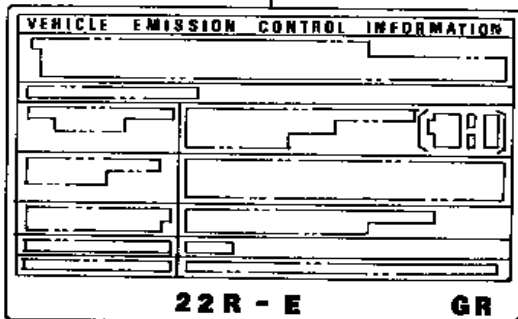

17791

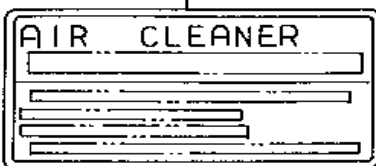

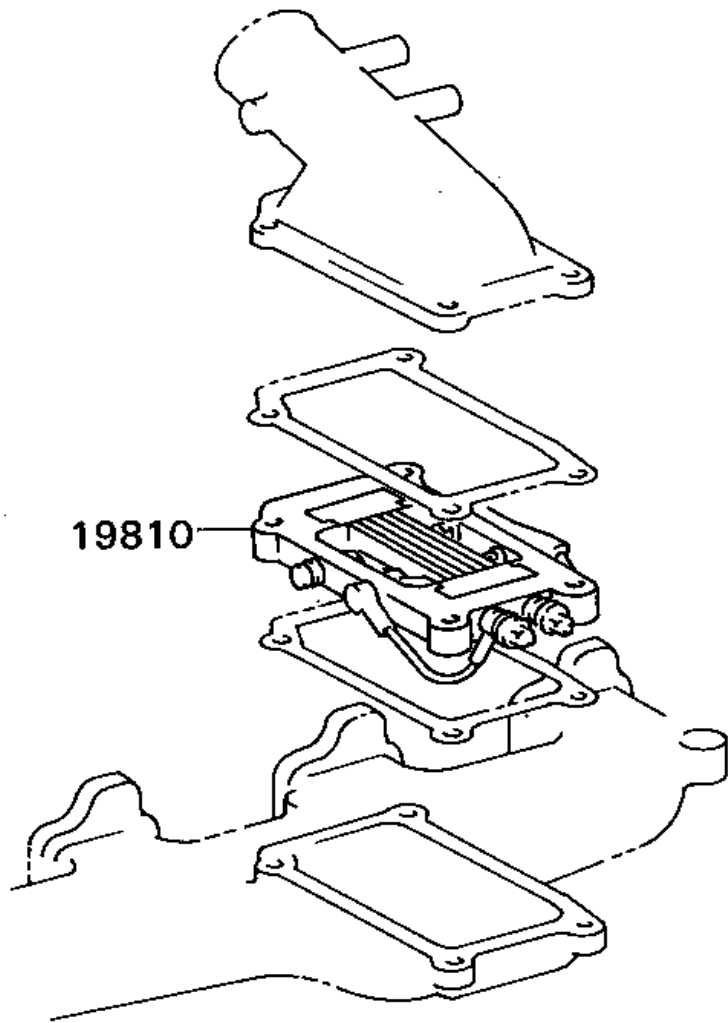

ME G719

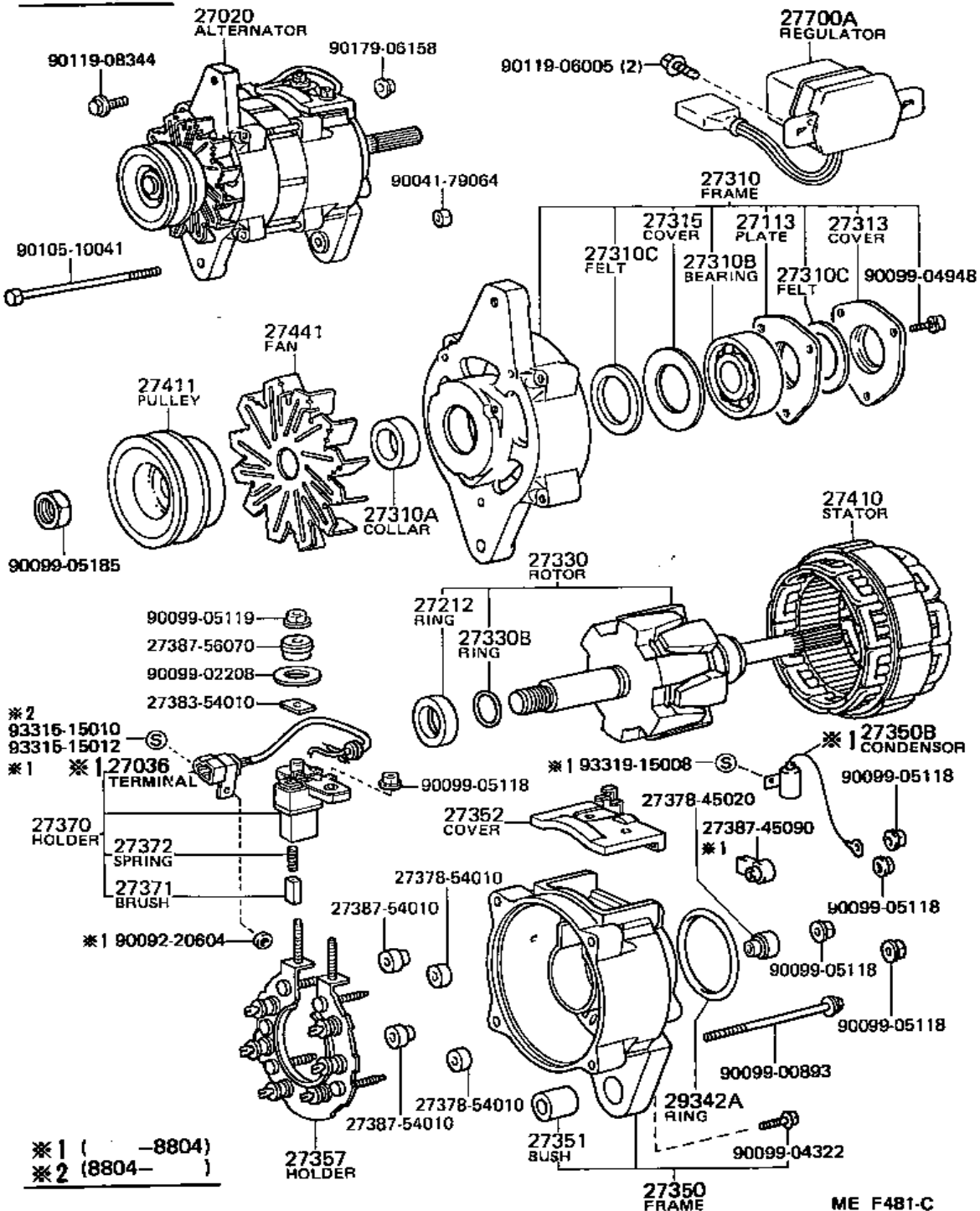

12V 2.5 KW
24V 4.5 KW

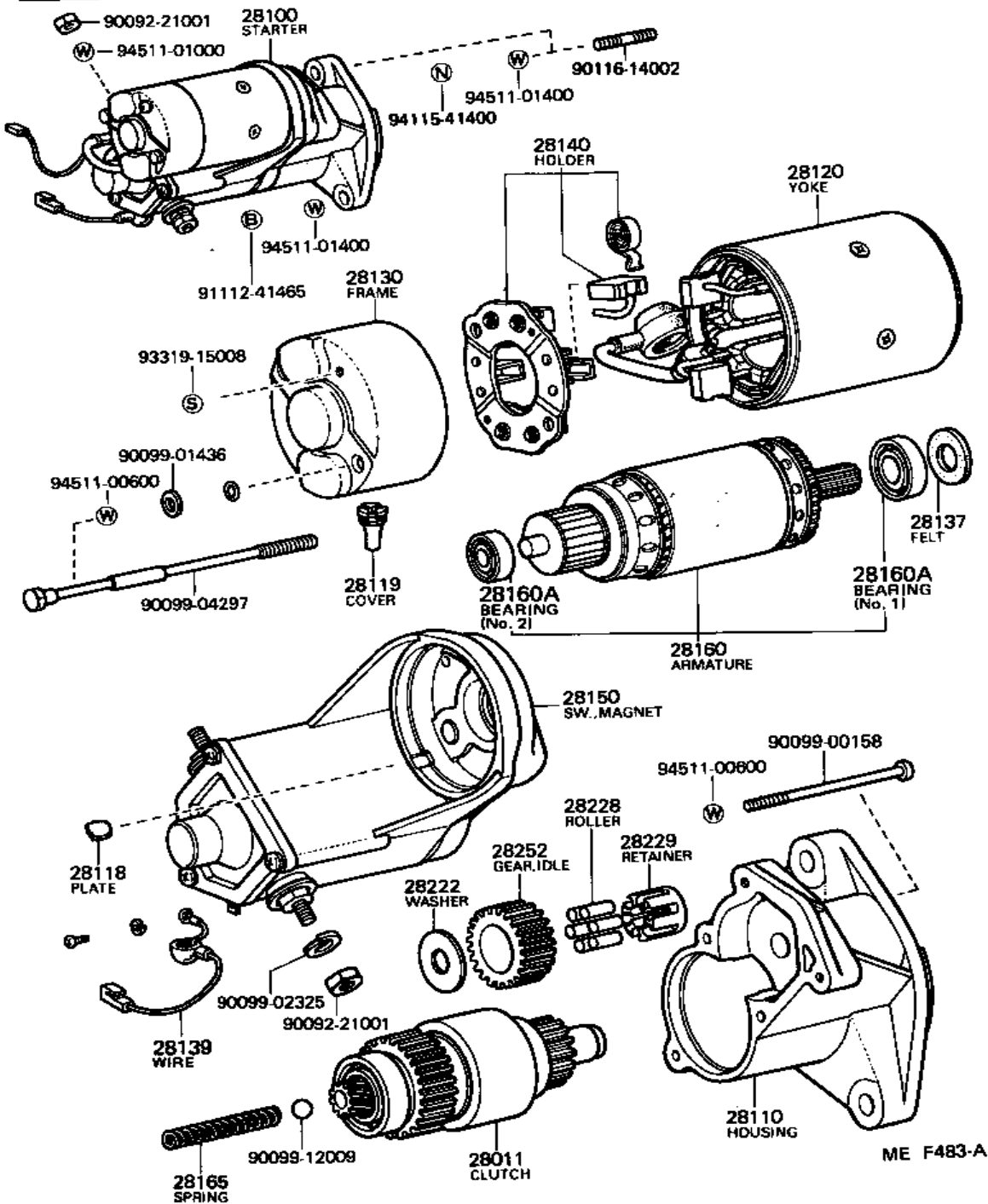

ME F483-A

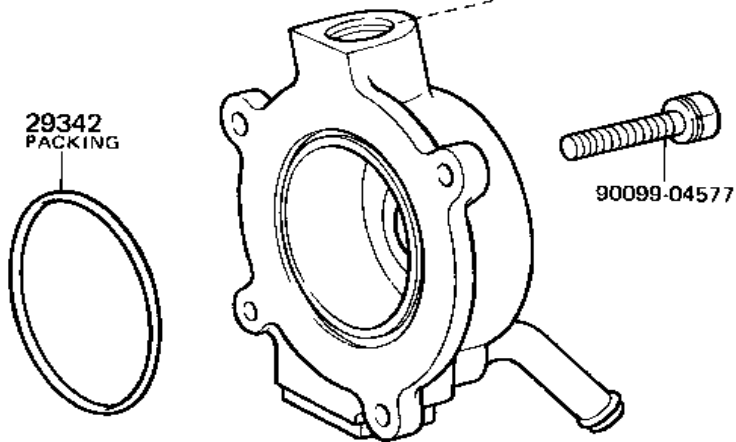
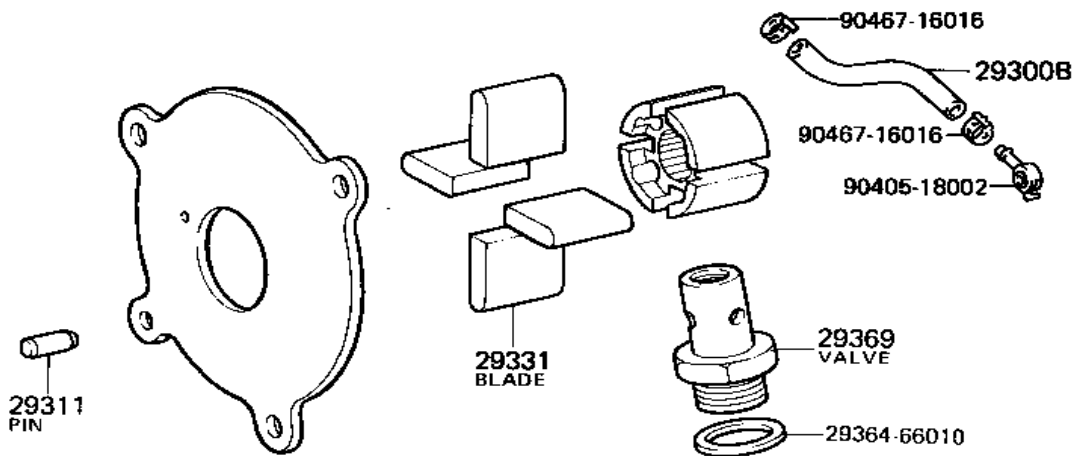
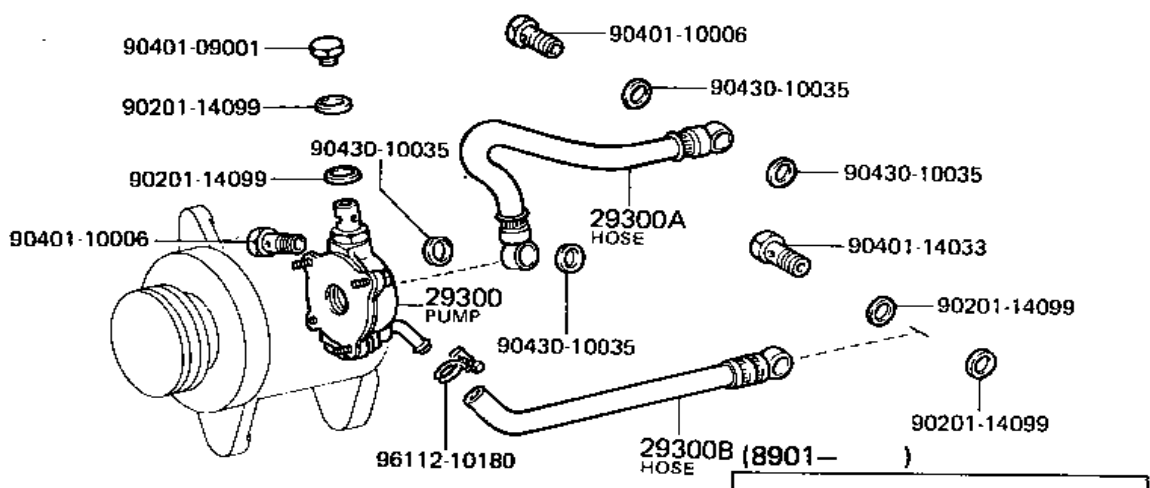

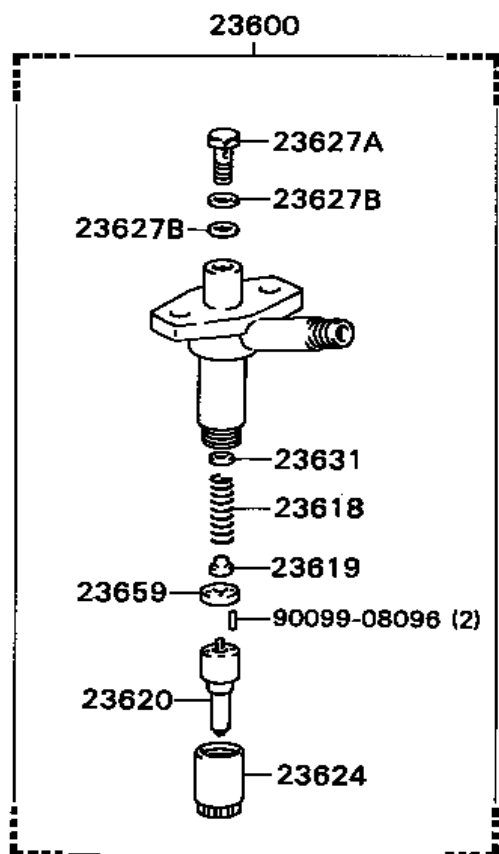
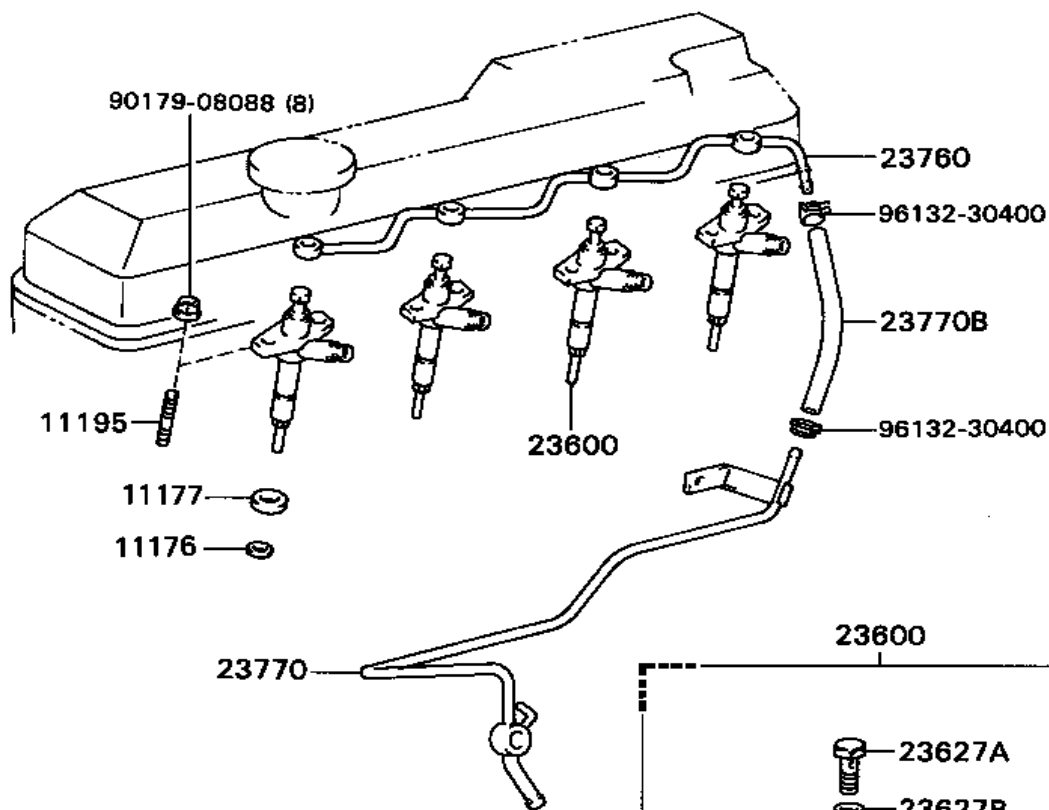

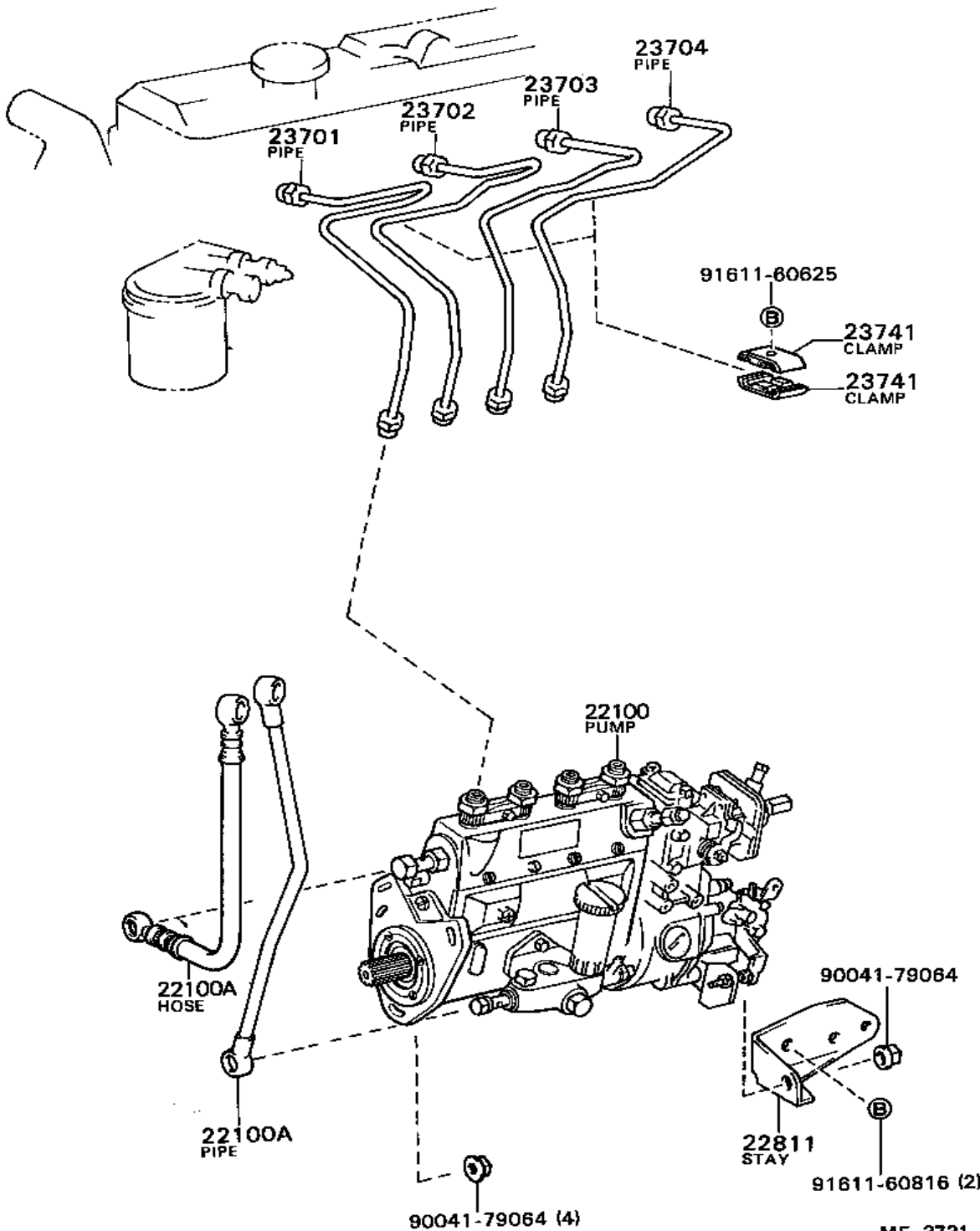

22131 HOLDER
22102 PLATE SET

22194 STOPPER
90099-14070

22148 SPRING

22149 GASKET

22104 VALVE

22105 ELEMENT

22156 SCREW

22155 PINION

22142 SLEEVE

22143 SEAT

22144 SPRING

22145 SEAT

22182 PLATE

22106 TAPPET

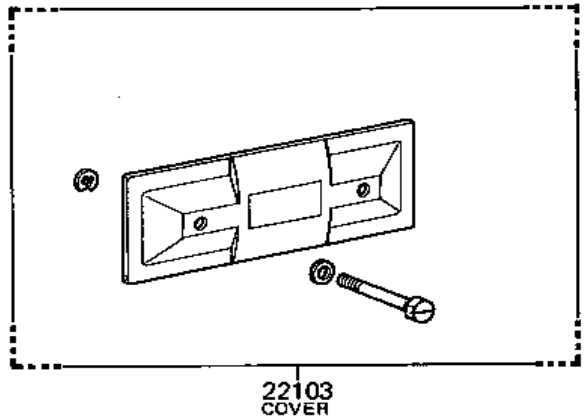

22103 COVER

22160 SCREW

22119 WASHER

22119 WASHER

22115 SCREW

22114 RACK

94712-77121

90099-18010

94712-77121

22116 COVER

90201-08106

22181 FLANGE

22195 GASKET

22174A KEY

90099-10151

22147 RING (No. 2)

22161 PLATE (No. 2)

90099-01451

90099-00894

22173 WASHER

90099-01451

90401-10006

22611 NUT

22174 SHAFT

22181A SEAL

90033-66011

22161 PLATE (No. 1)

22147 RING (No. 1)

22146 CAMSHAFT

22157 PLUG

Refer to FIG. 22-06

Refer to FIG. 22-06

Refer to FIG. 22-06

90099-00928 (4)

MF 3397

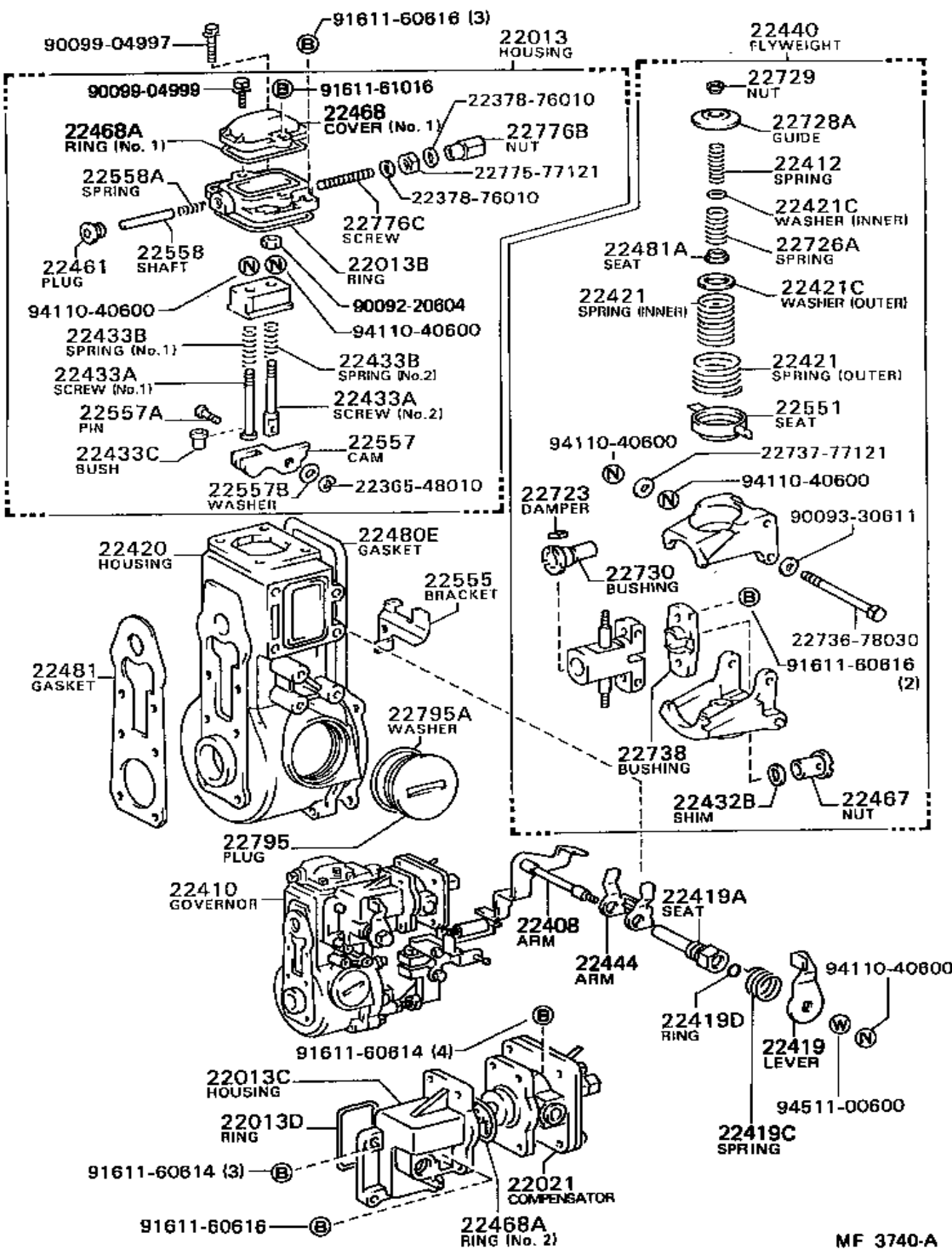

91611-60616 (2)

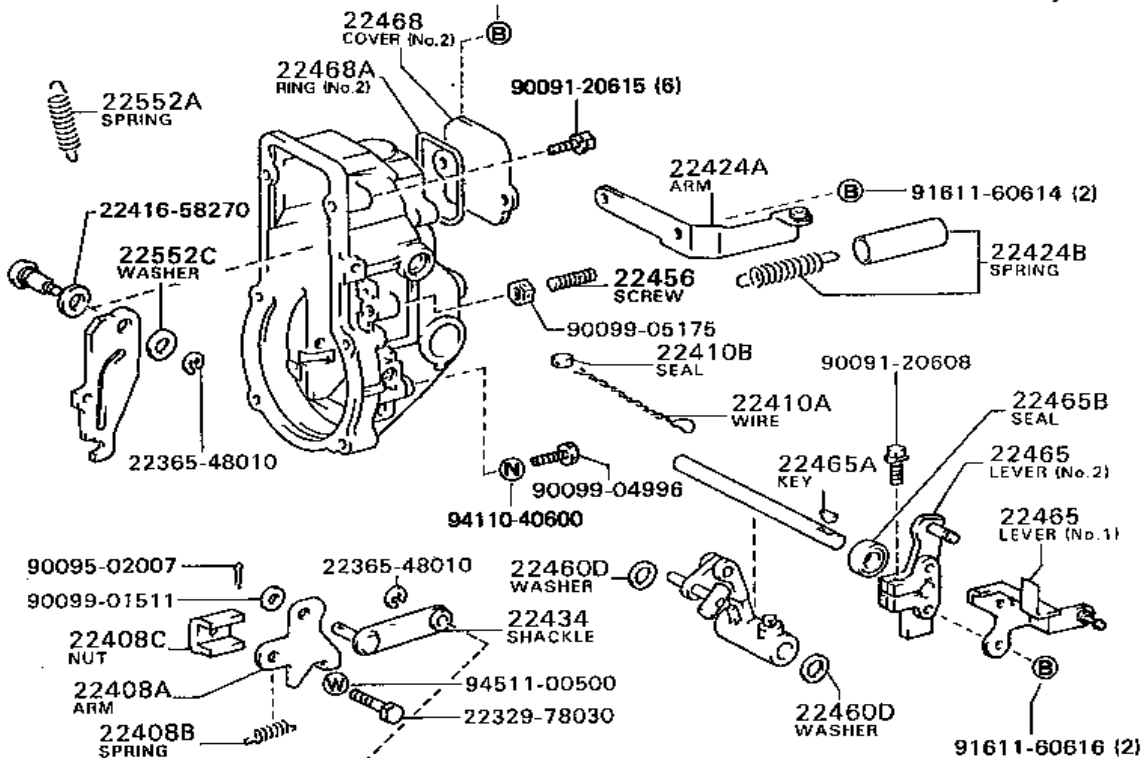

INJECTION PUMP HOUSING
X GOVERNOR HOUSING

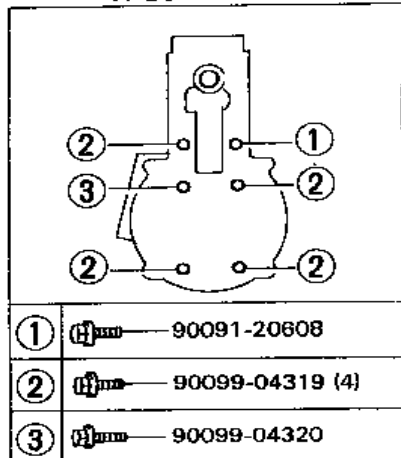

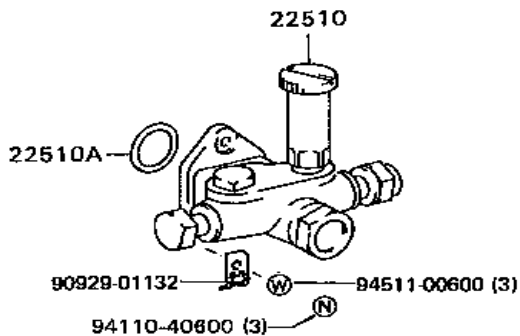

※ 113BT

22510

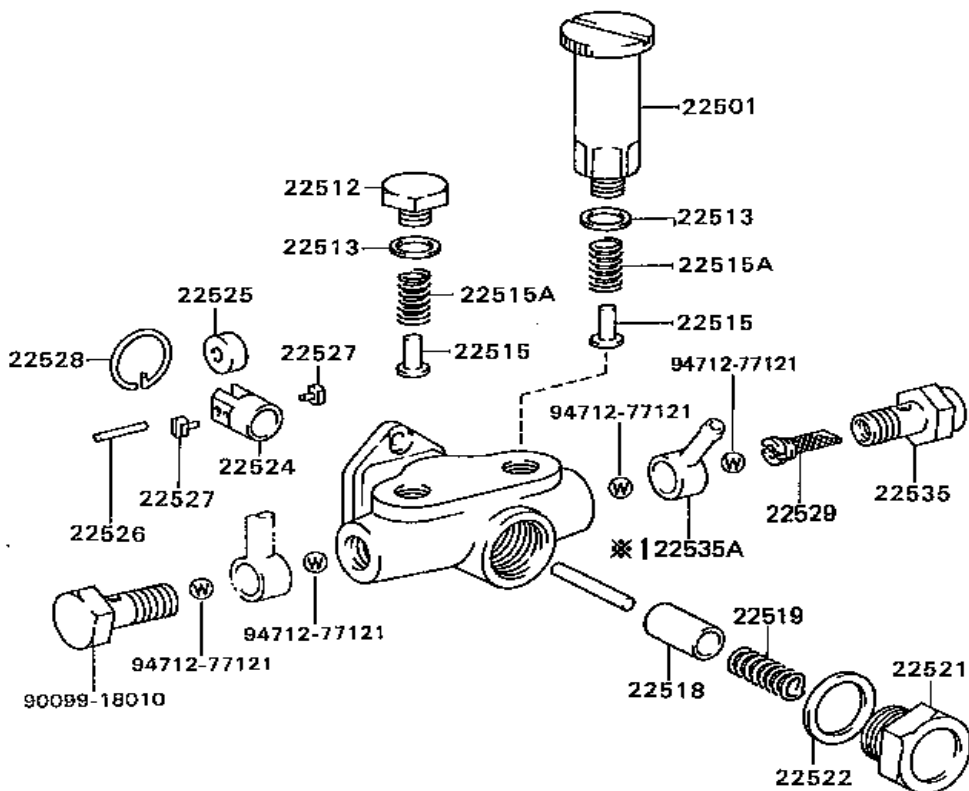

MAE434

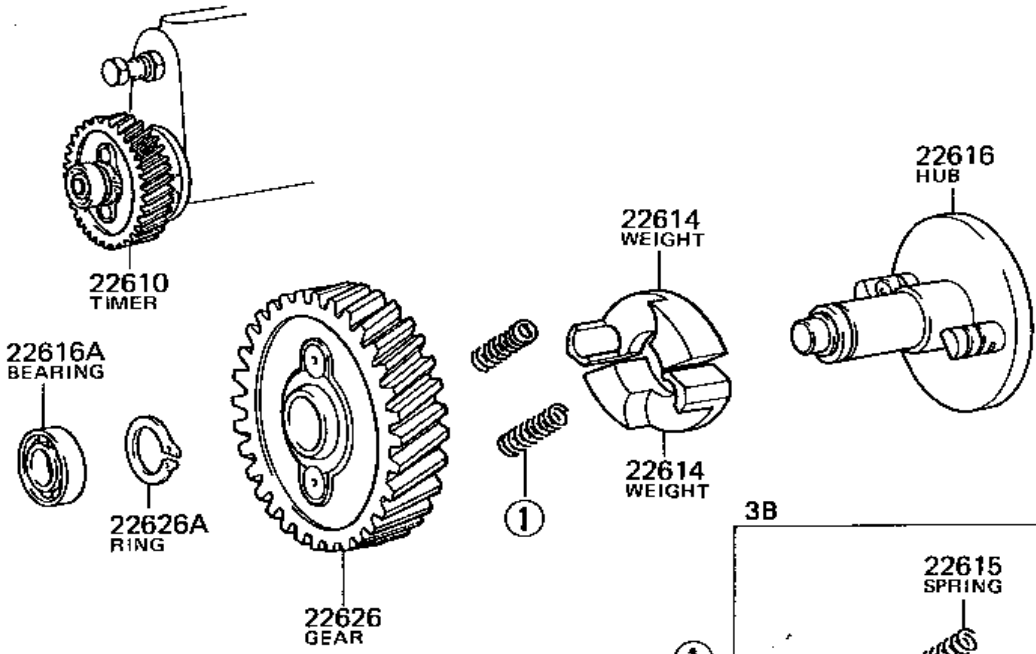

3B

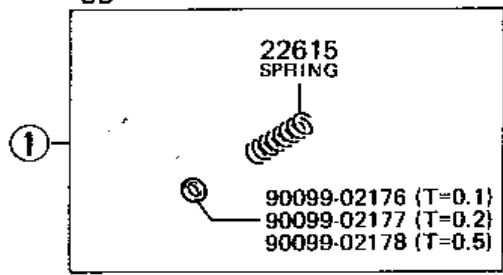

13BT

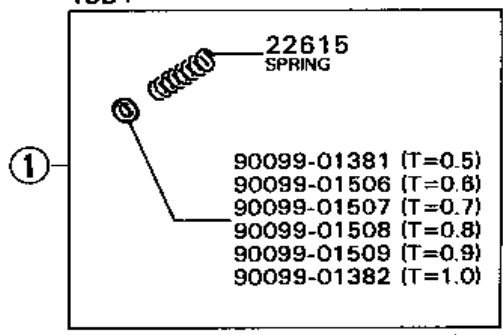

91611-61045 (2) **B**

23300D

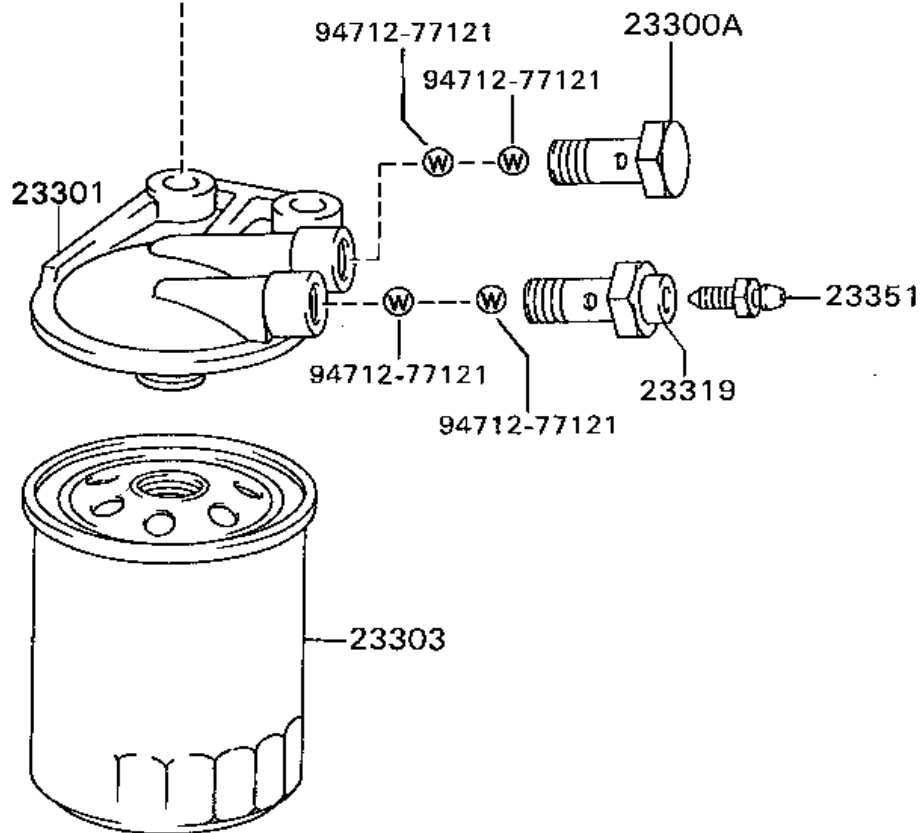

MF 3732

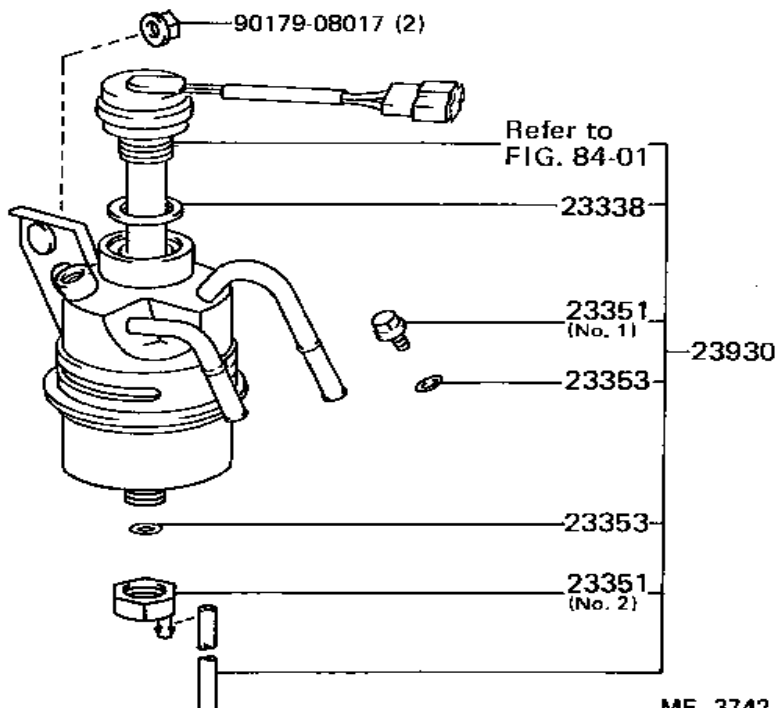
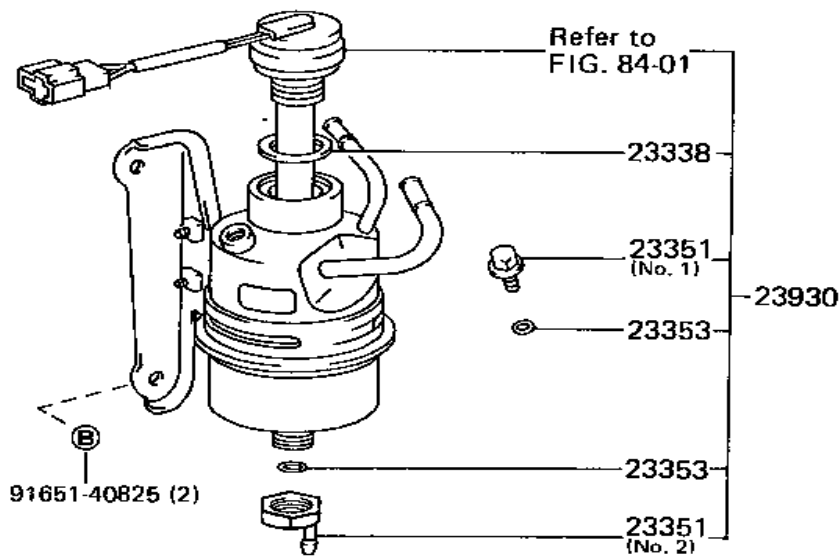

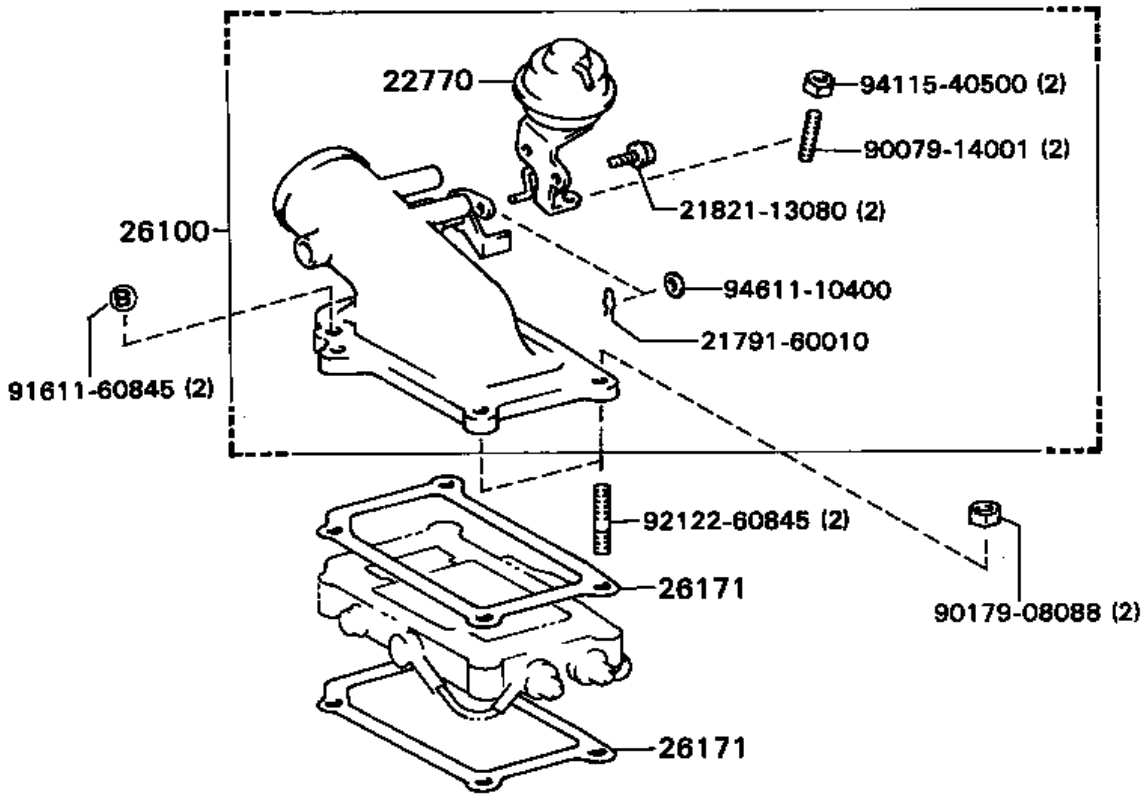

MF 3404-A