

1HZ

11000

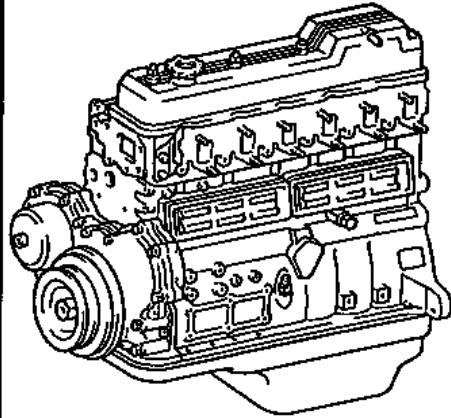

2LT

11000

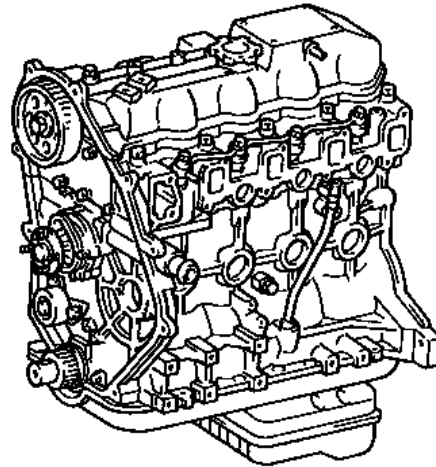

22R#

11000

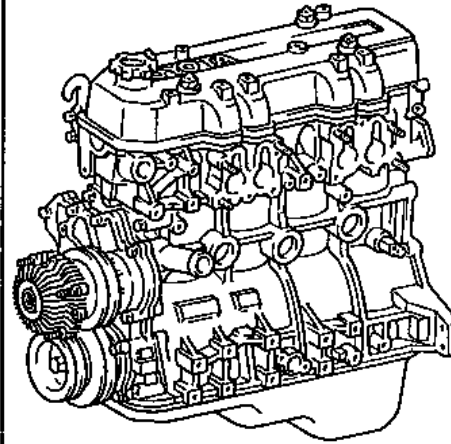

1PZ

11000

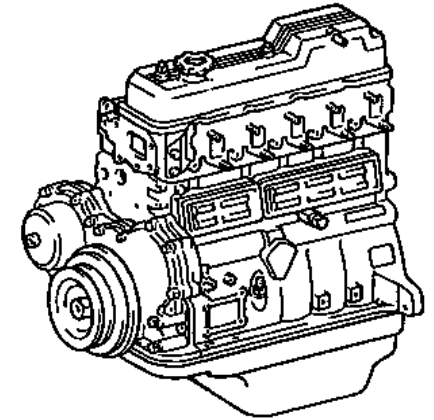

1KZT

11000

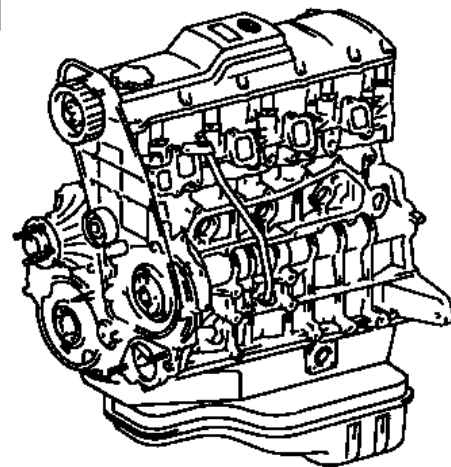

1HZ

11400

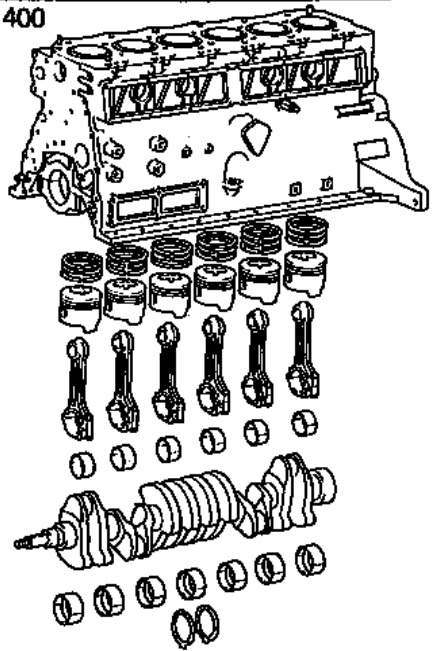

2LT

11400

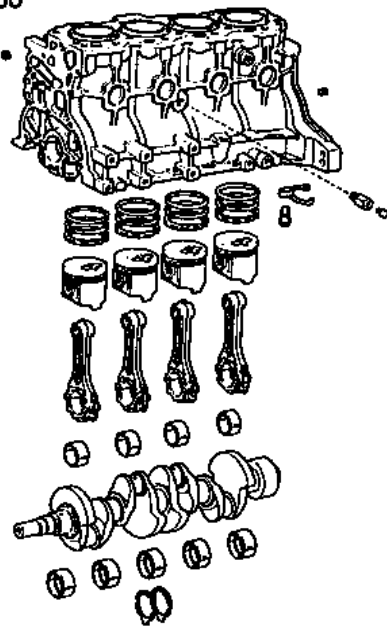

1PZ

11400

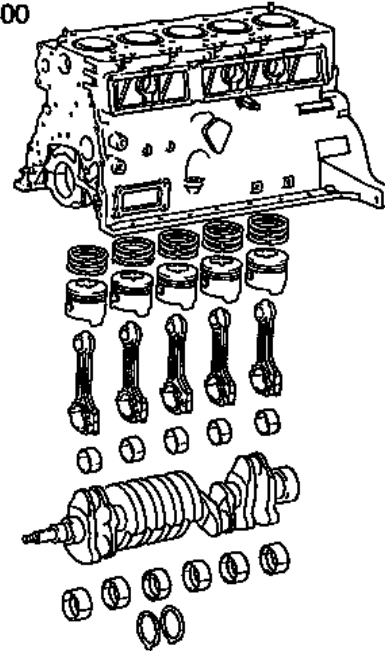

22R#

11400

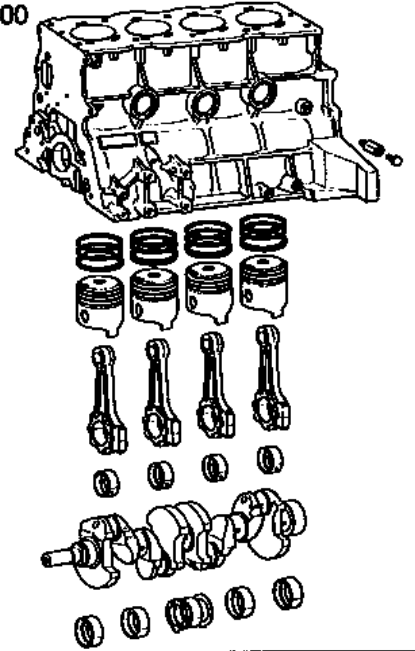

1KZT

11400

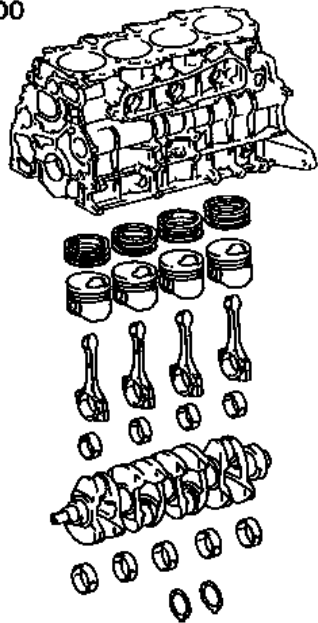

04111

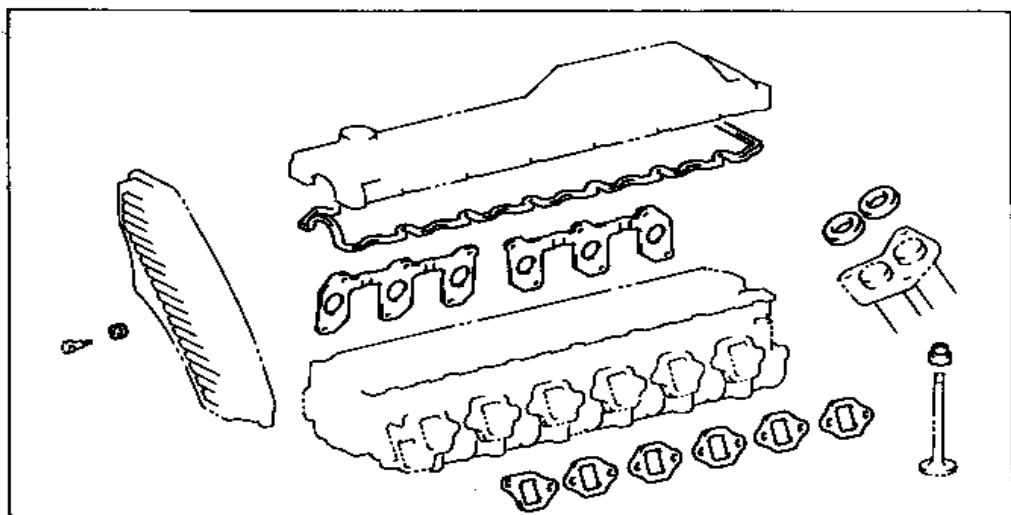

04112

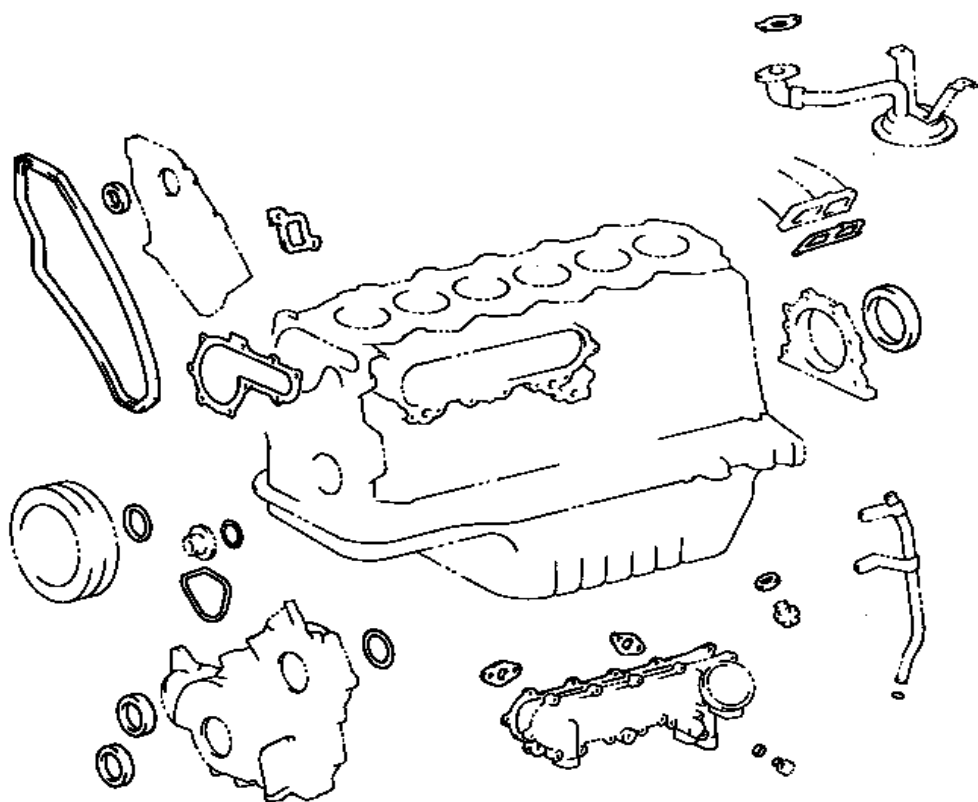

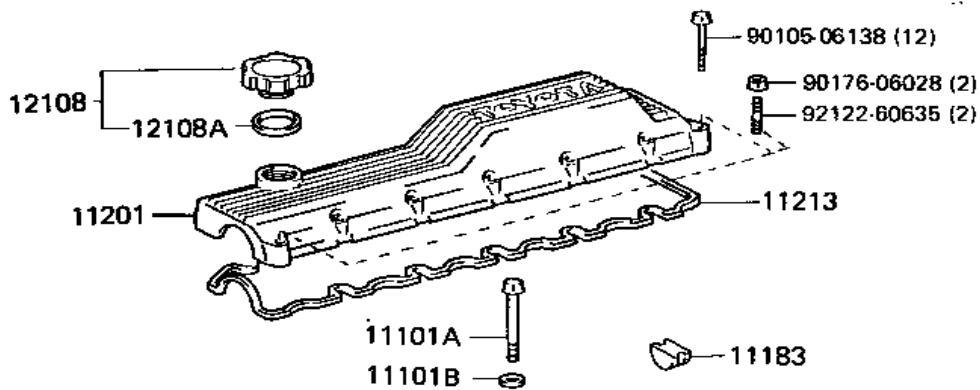

11101

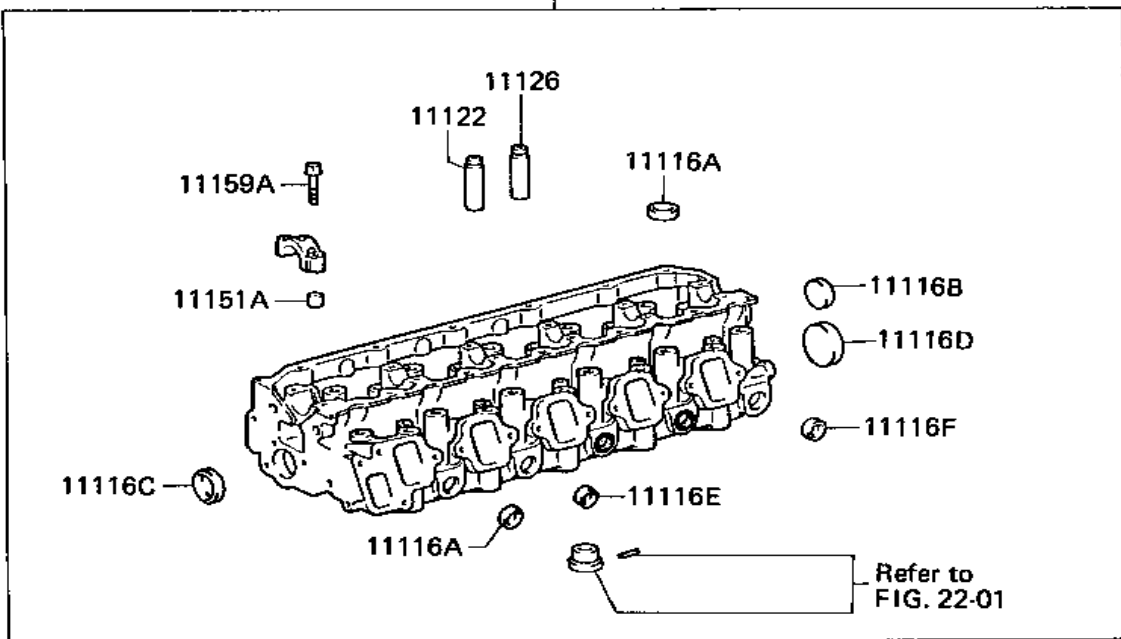

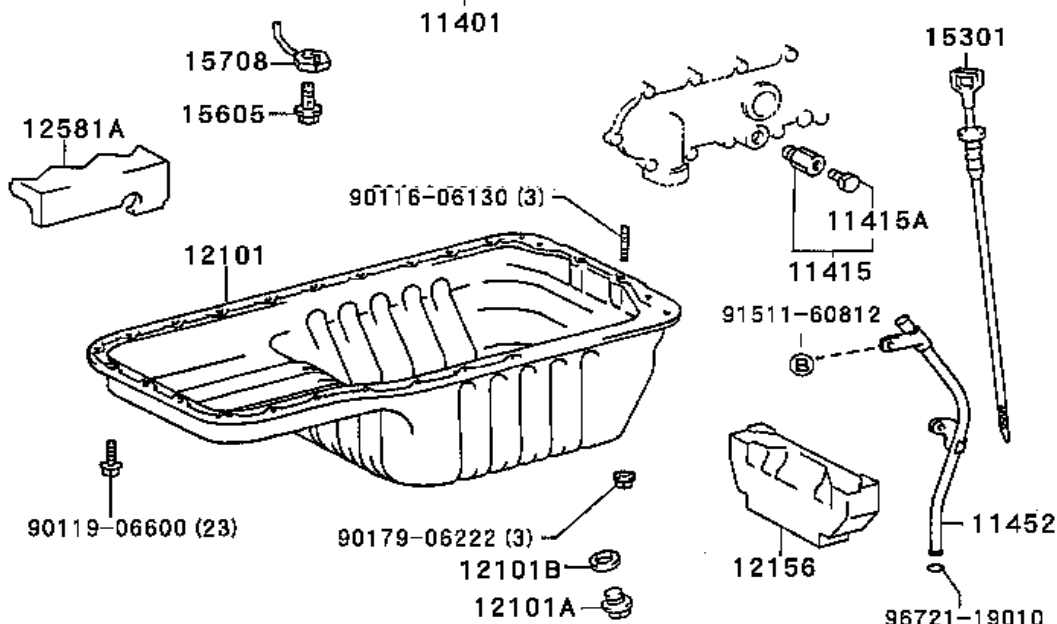
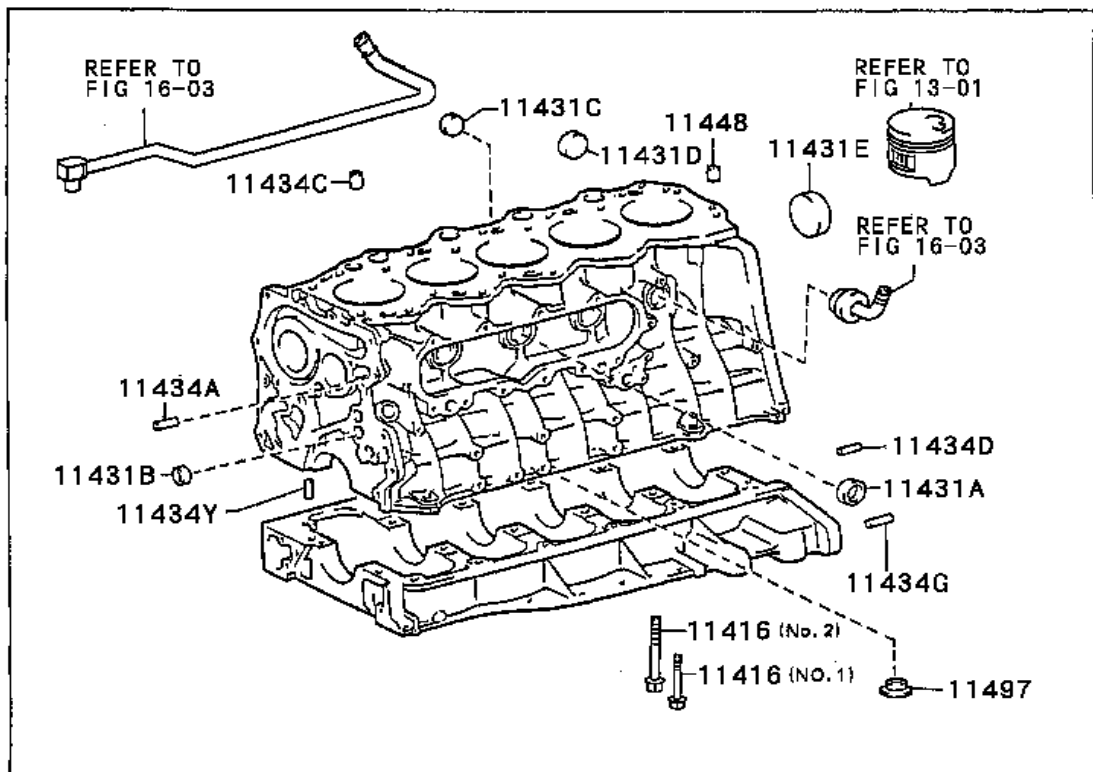

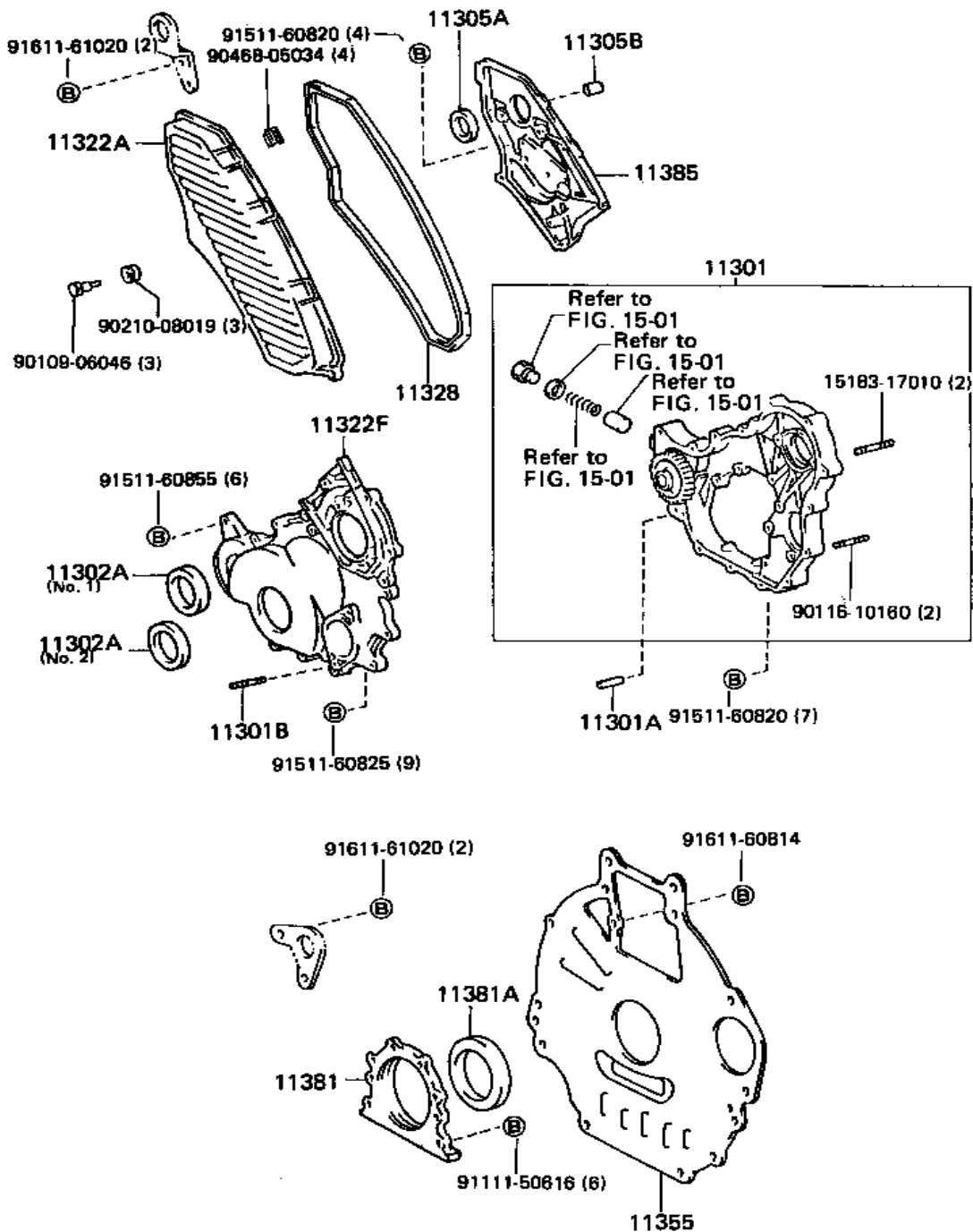

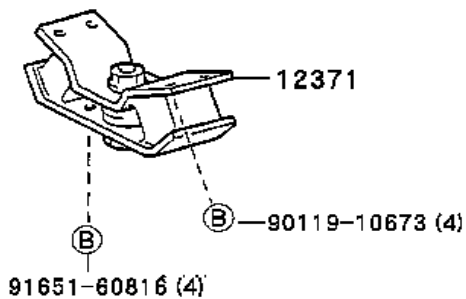
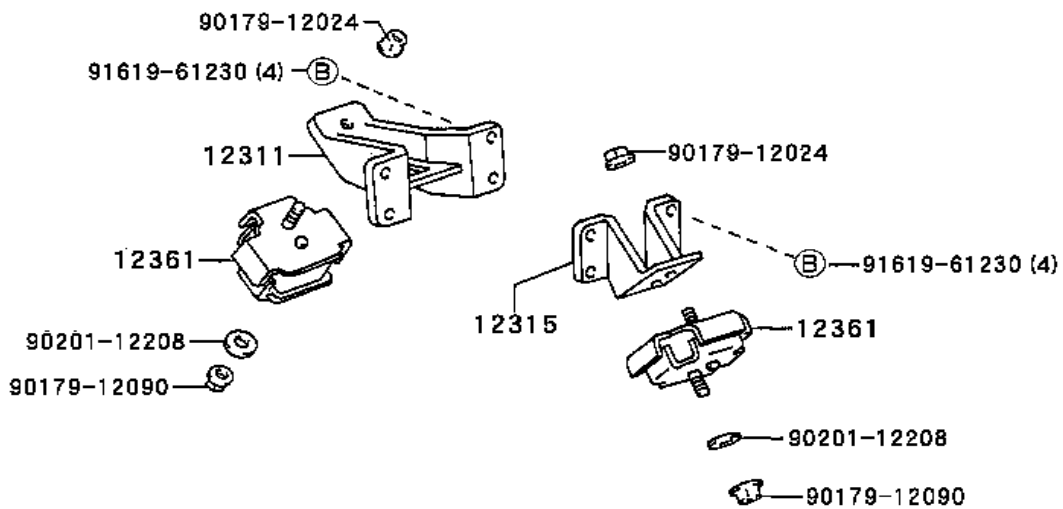
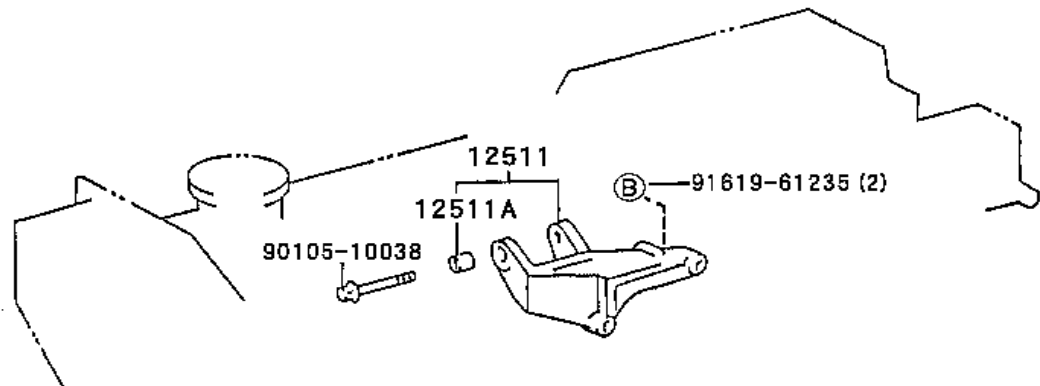



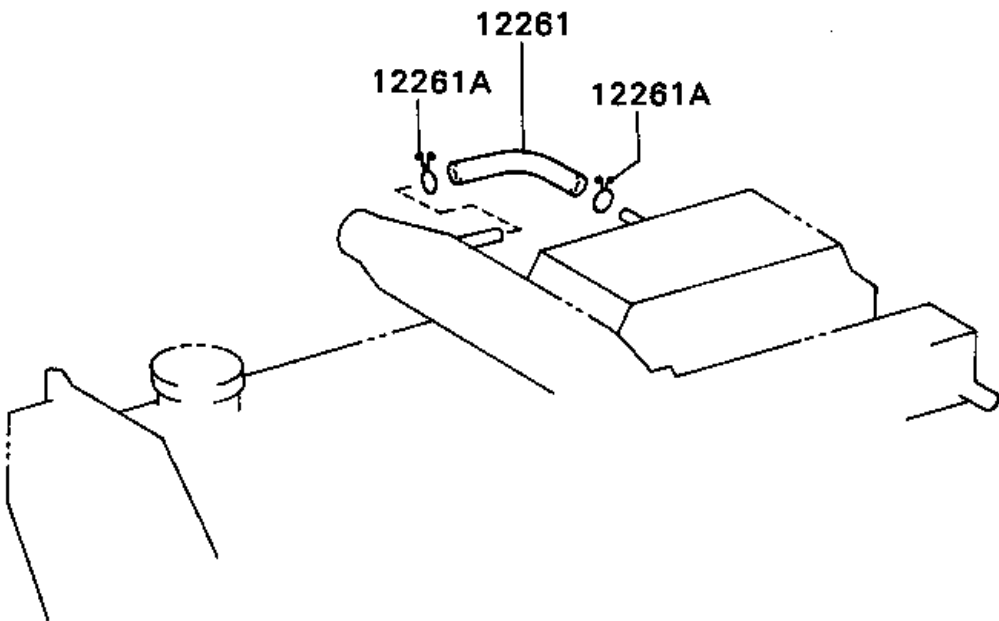

MA D428

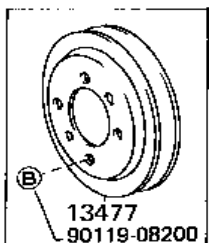
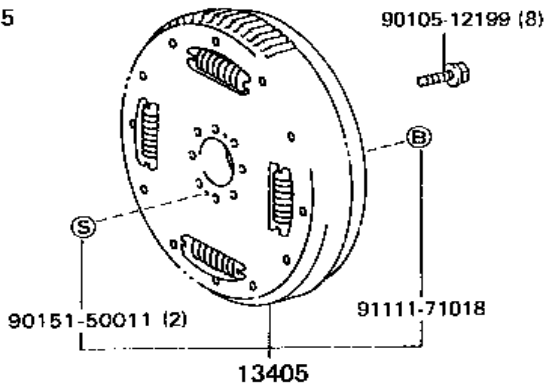
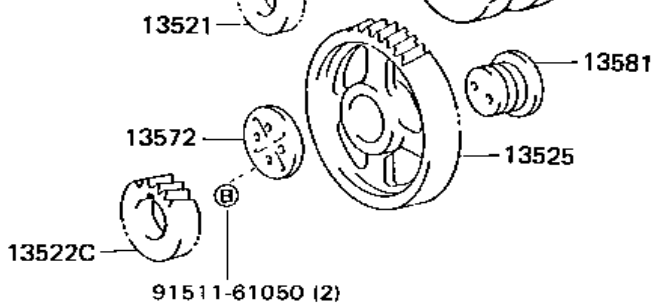
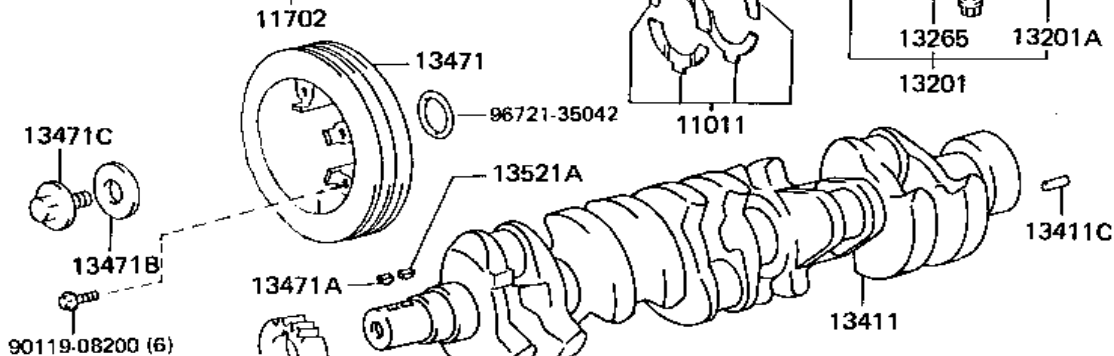
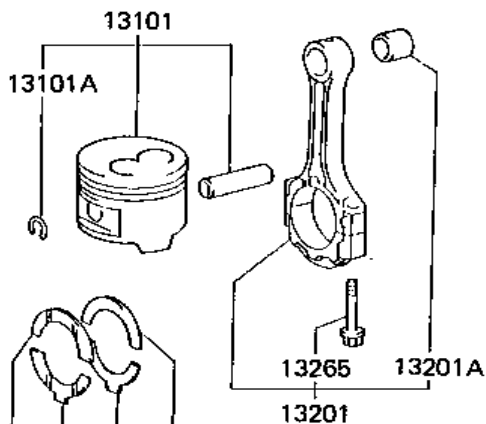
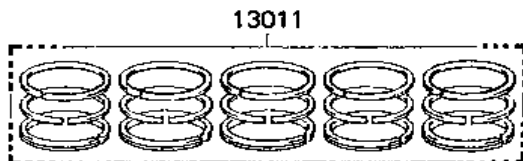
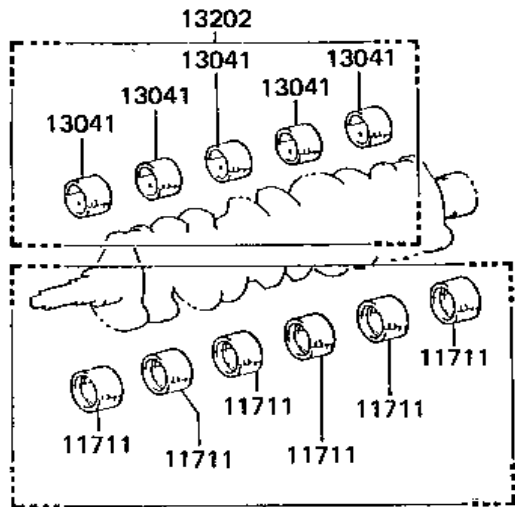

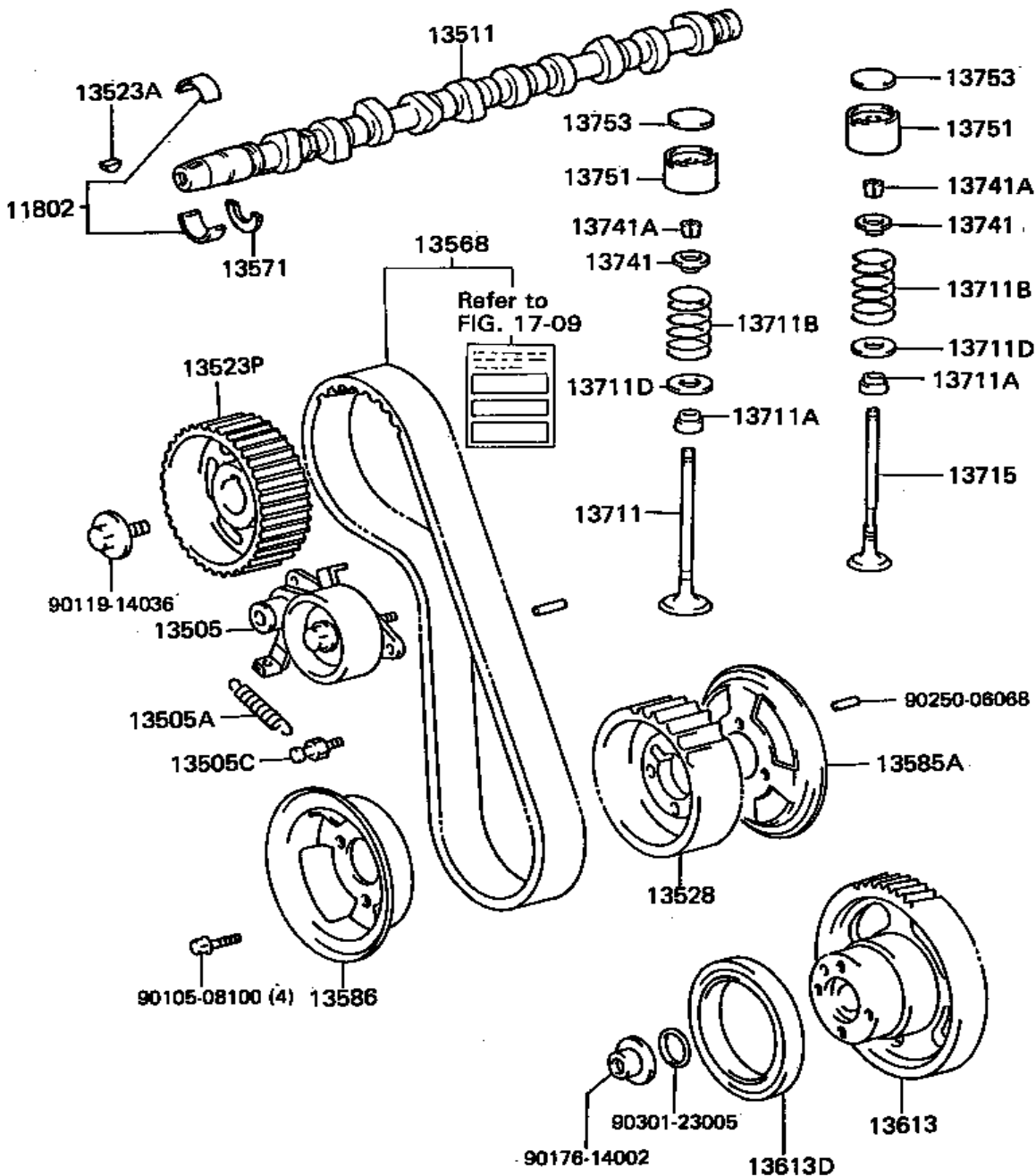

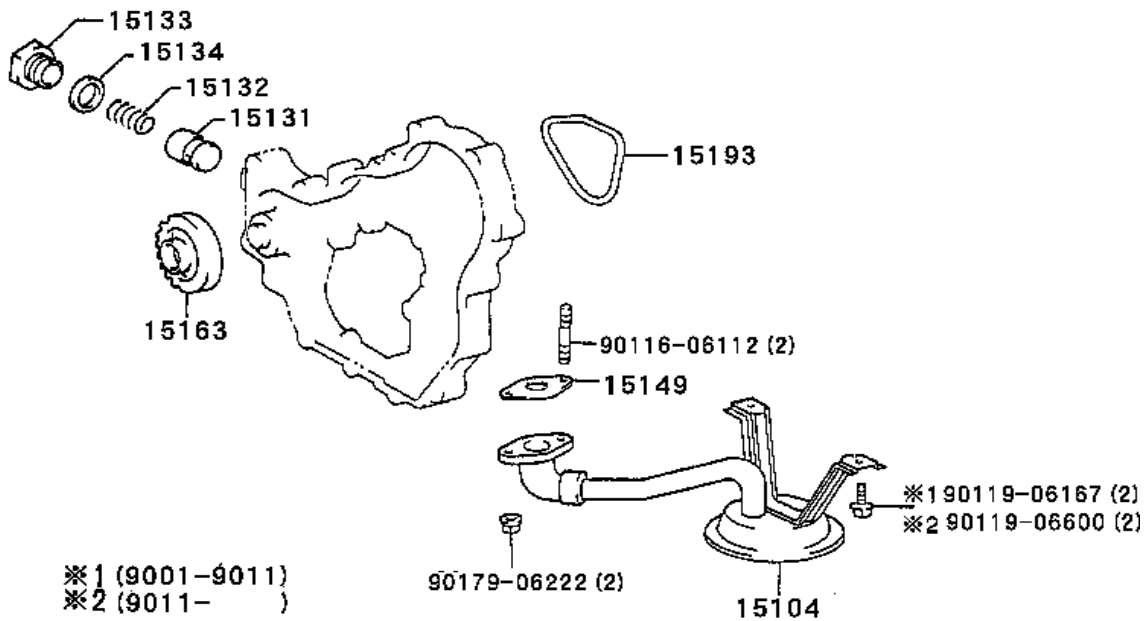

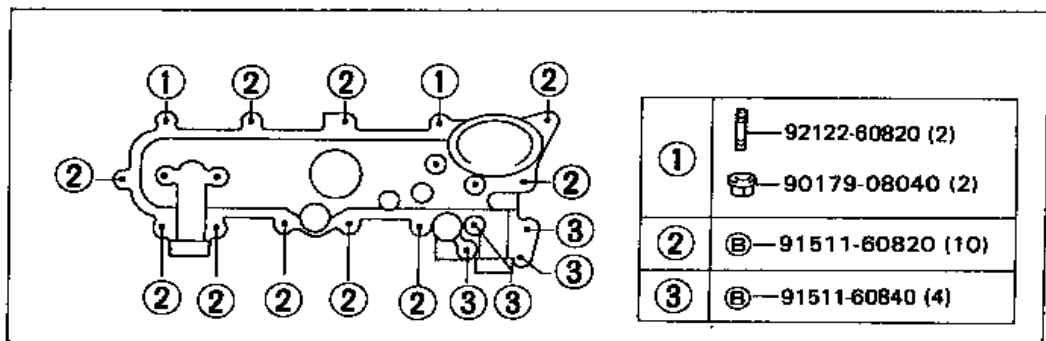
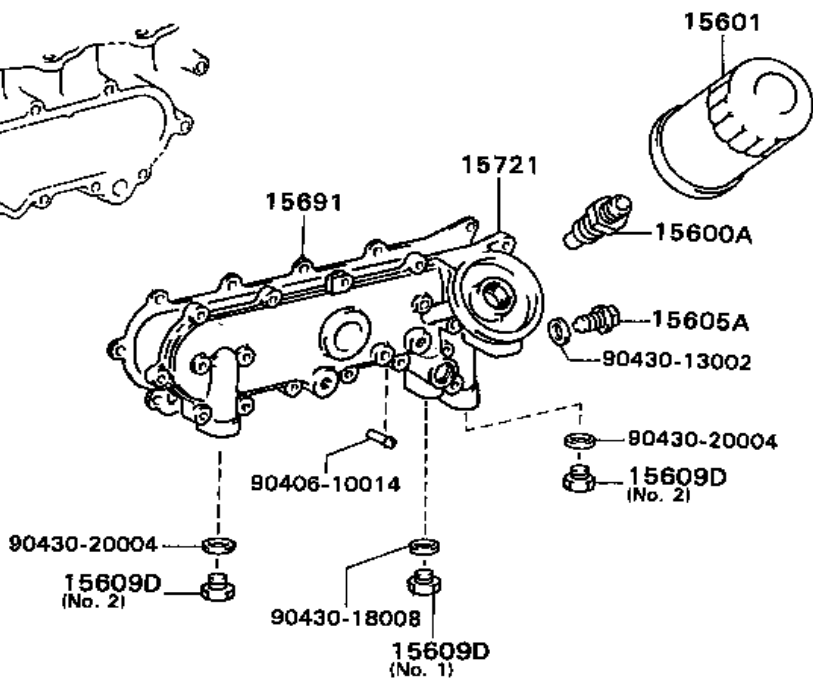
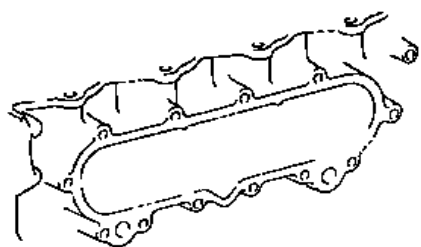

MA D582-B

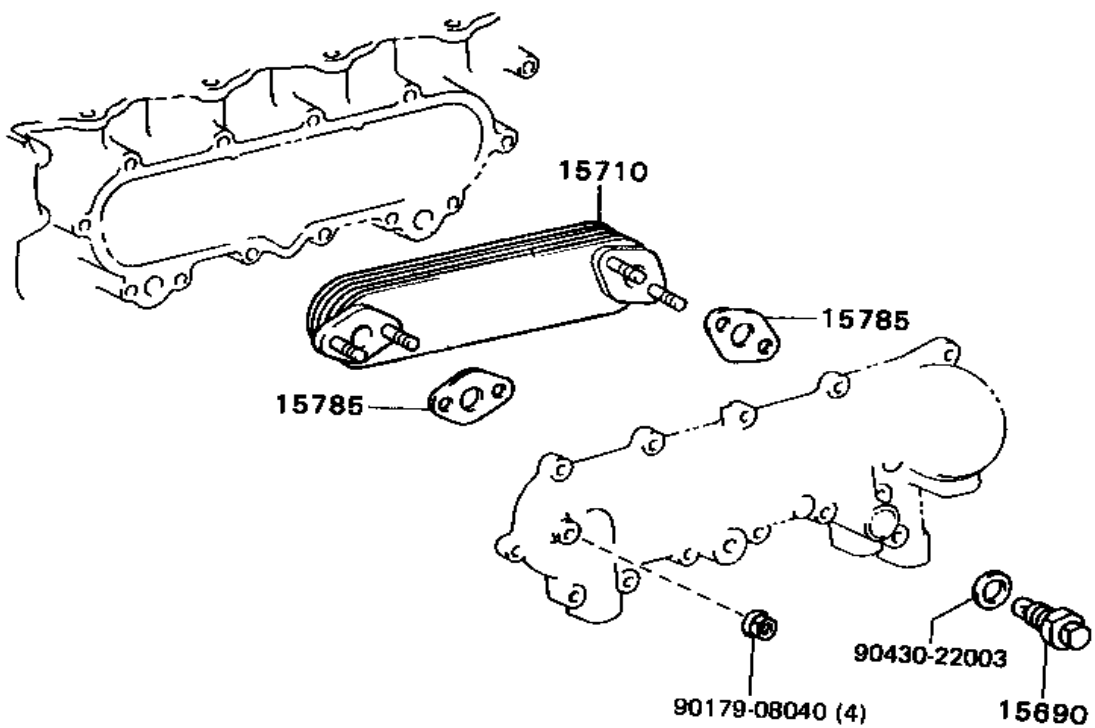

MA D486-B

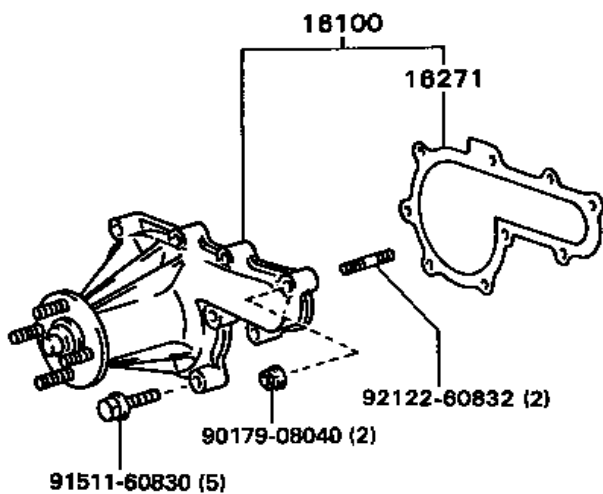
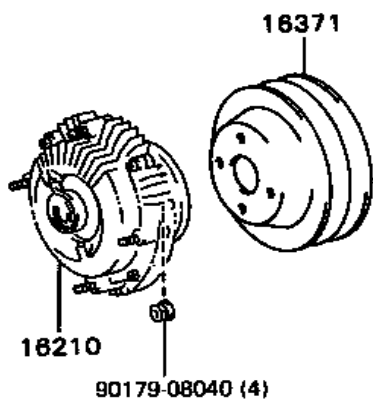

MA D522-D

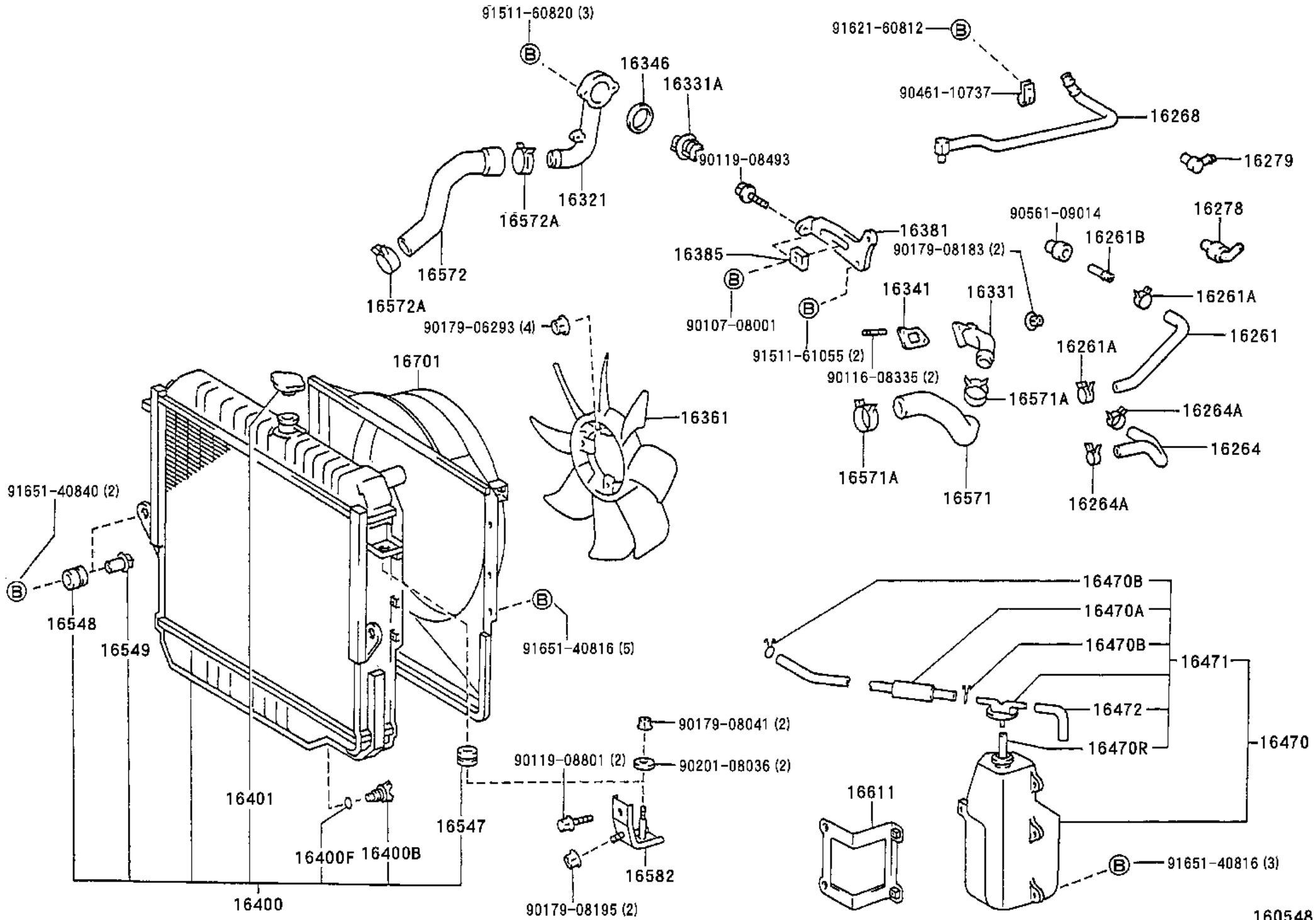



IP : Idle Pulley  
 VP : Vane Pump  
 WP : Water Pump  
 AL : Alternator  
 CK : Crankshaft  
 CC : Cooler Compressor

AP : Air Pump

	PNC		
	16361A		
	44310A		
	88310A		

22R#

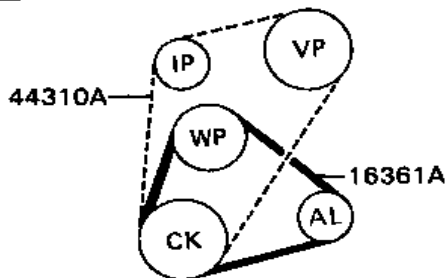

3B

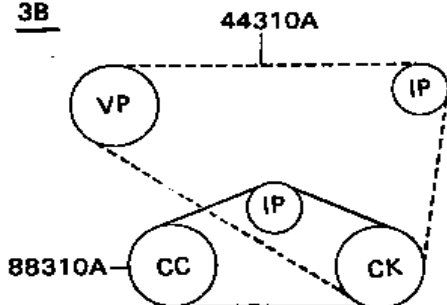

1KZT

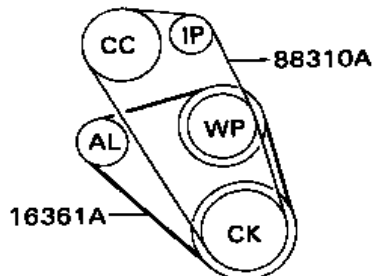

1HZ, 1PZ

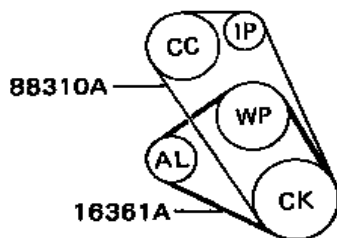

2LT

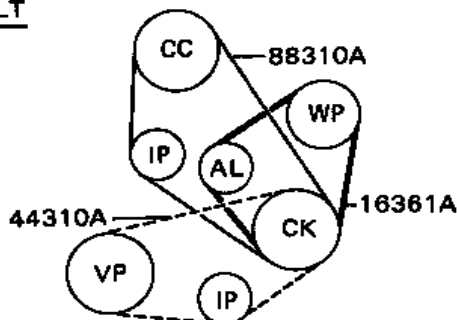

91621-60812 (4)

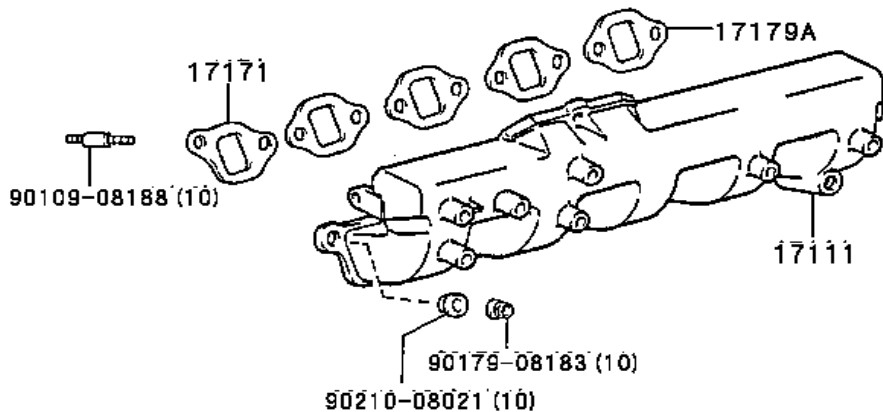
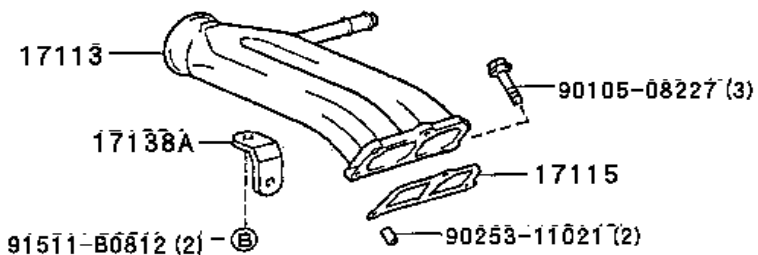
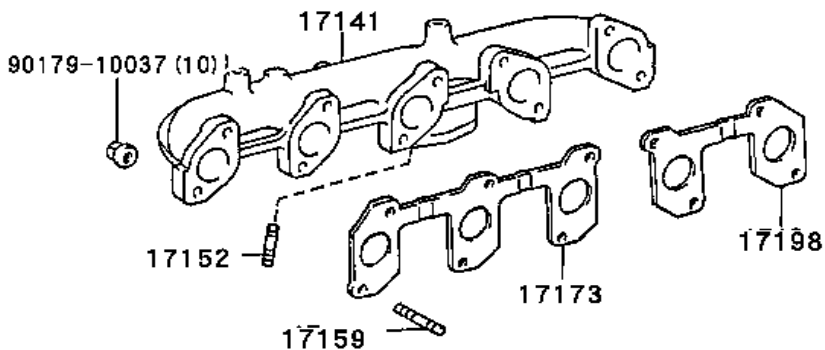
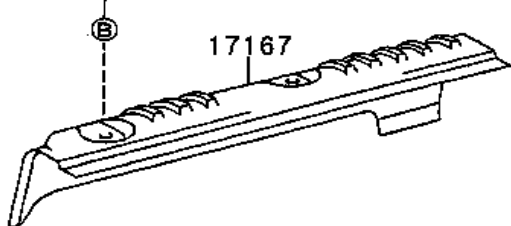

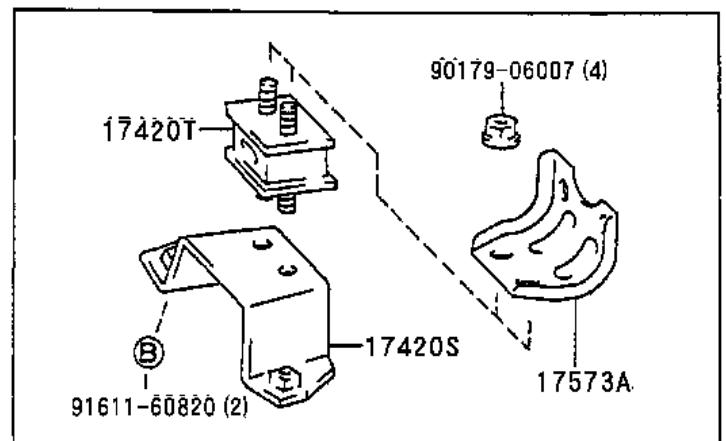
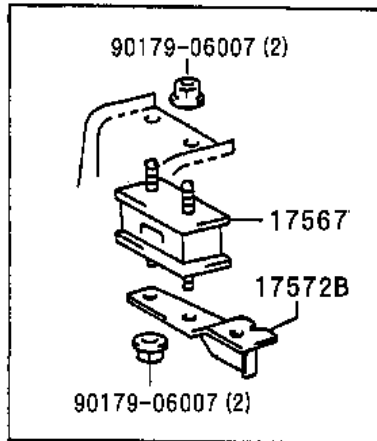
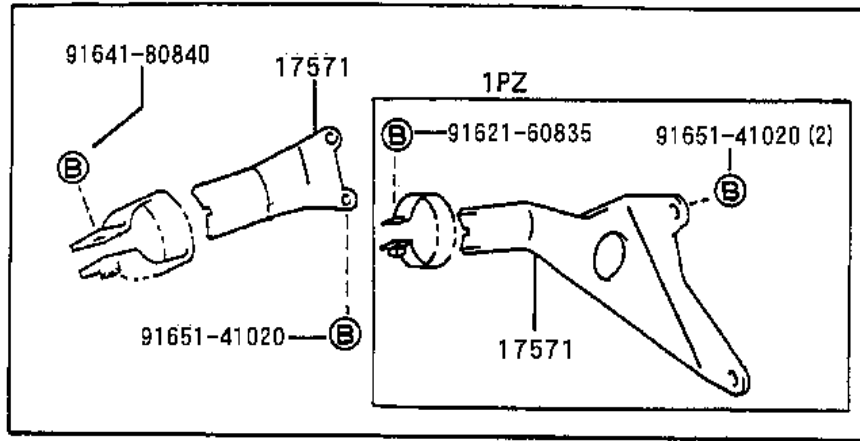

①

②

③

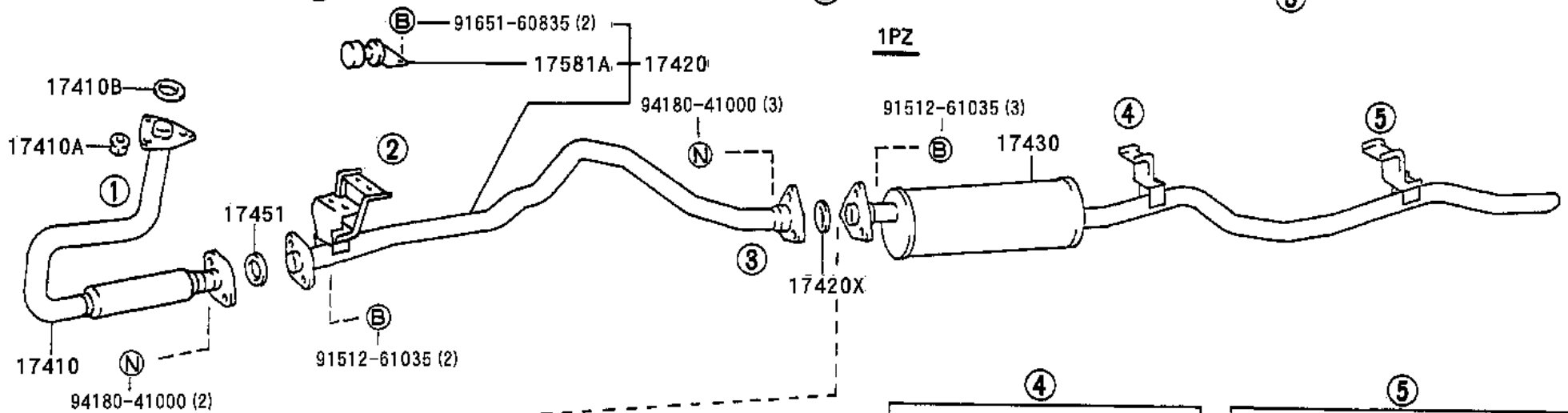

1HZ

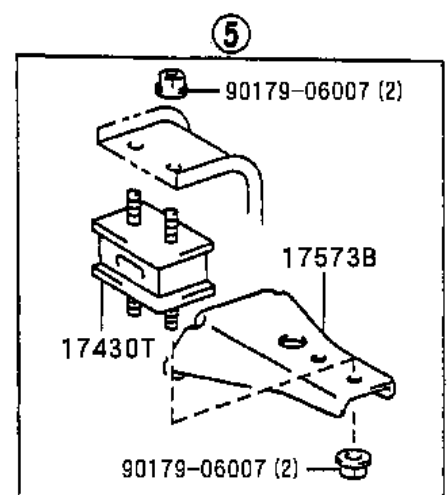
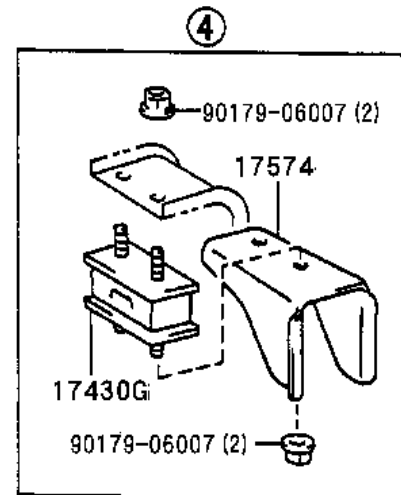
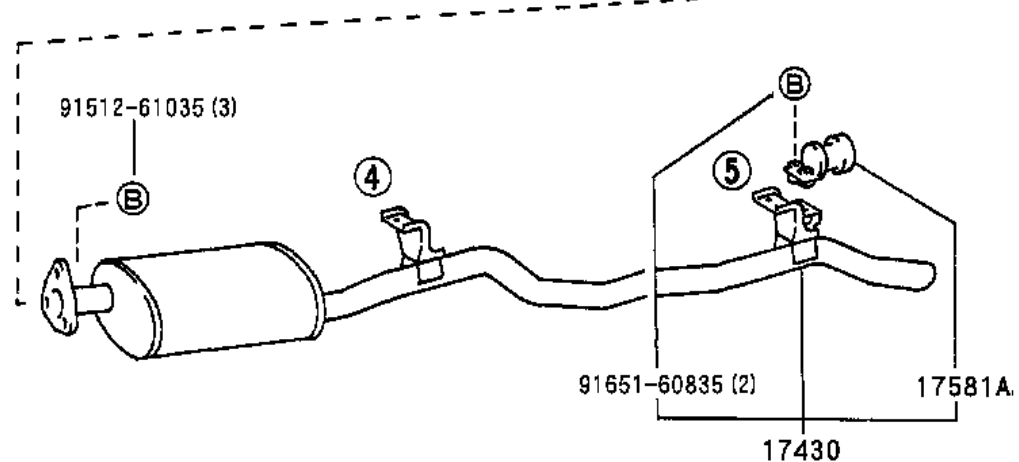

④

⑤

17430

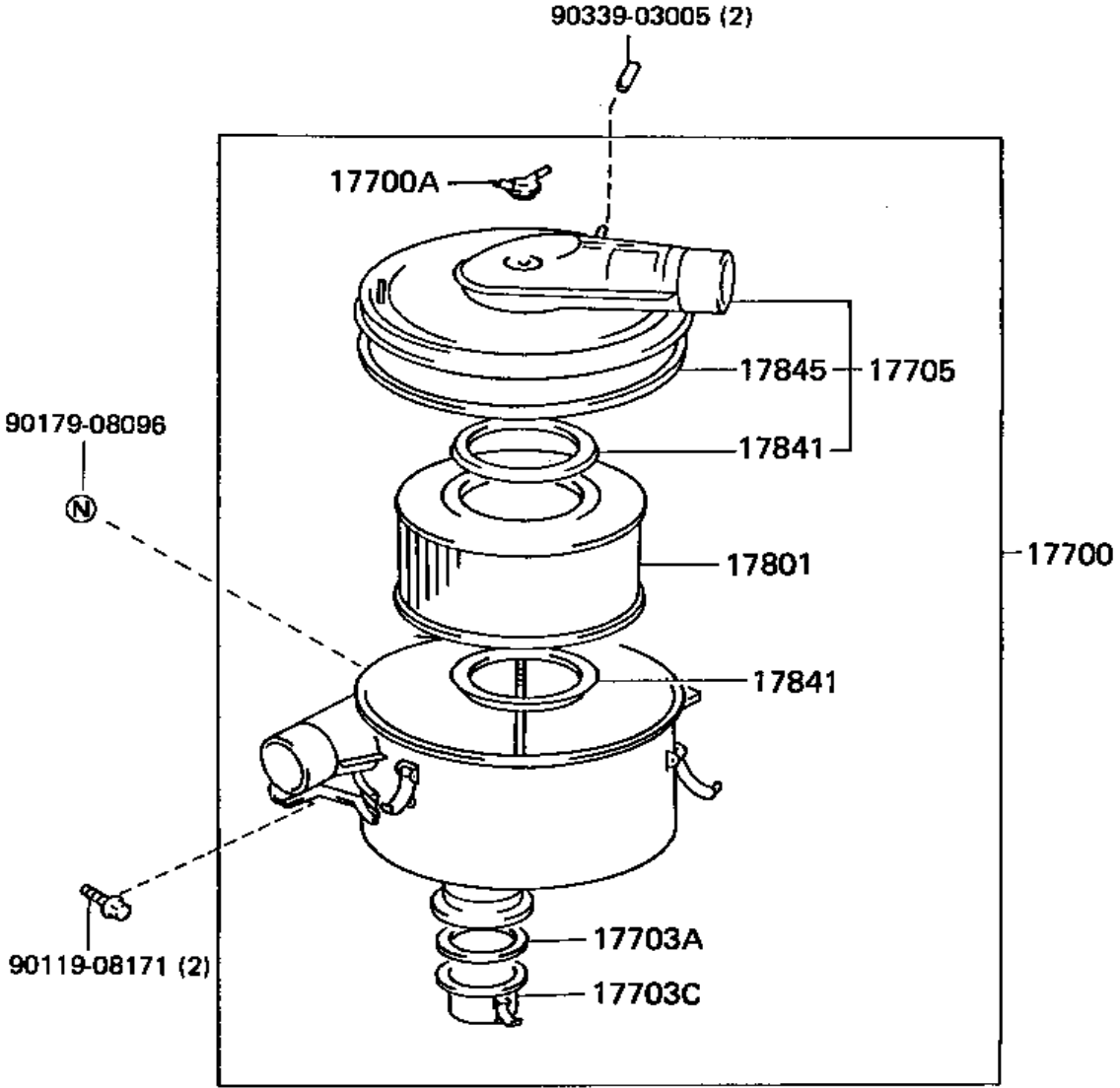

MA D587

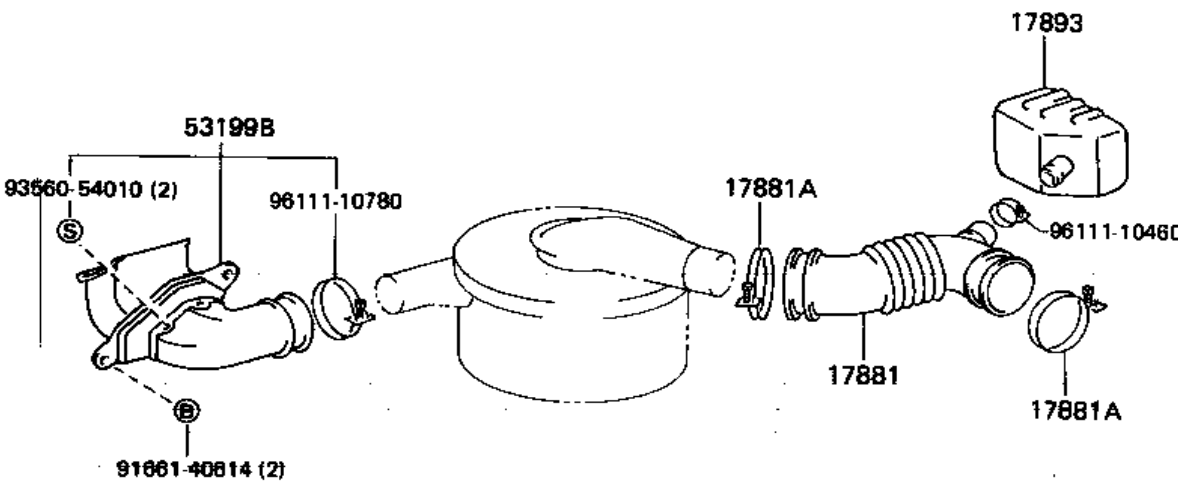

MA D588-B

## Vacuum Hose Supply Method

Supply of Vacuum Hose is determined in length specified below.

Necessary Length	Part Number	Length available
Below 300 mm	90999-92002	300 mm
301 to 600 mm	90999-92003	600 mm
601 to 950 mm	90999-92004	950 mm
951 to 1300 mm	90999-92006	1300 mm
1301 to 1650 mm	90999-92007	1650 mm
1651 to 2600 mm	90999-92008	2600 mm

1. Actual replacement to vehicle could be made by cutting the hose into desired length.
2. Unlike the vacuum hose already installed in the vehicle, this replacement vacuum hose does not have the hose number printed on it. Accordingly, before installing this vacuum hose, write on it the same hose number as that written on the vacuum hose to be removed as shown below.

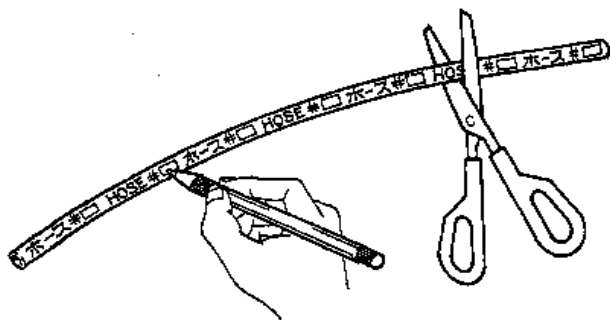
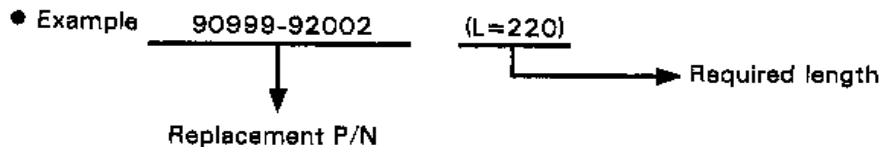

1. As hose is supplied in 300 mm length, cut off excess to meet desired length of 220 mm.
2. Using an oil-based marking pen or a ball-point pen, write the hose number at both ends of the hose, in accordance with the original hose number.

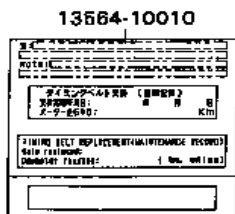
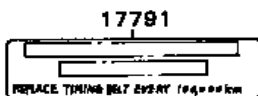
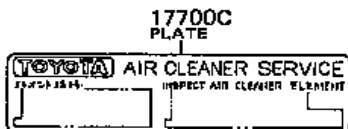
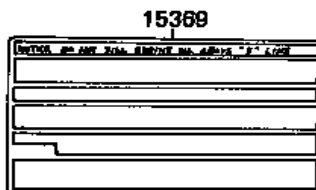
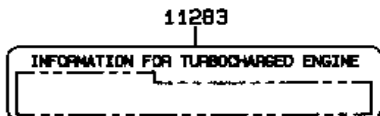
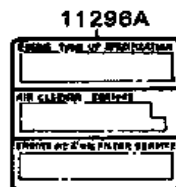
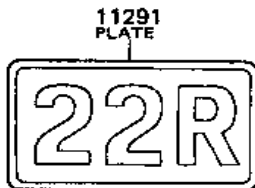

HOOD

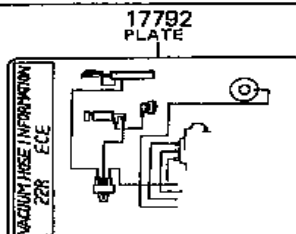
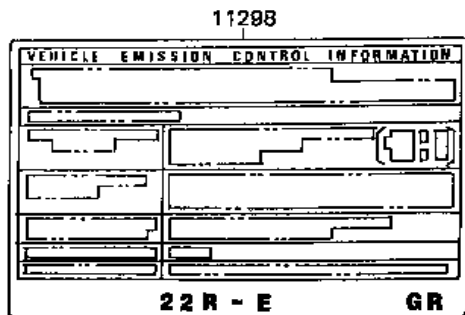

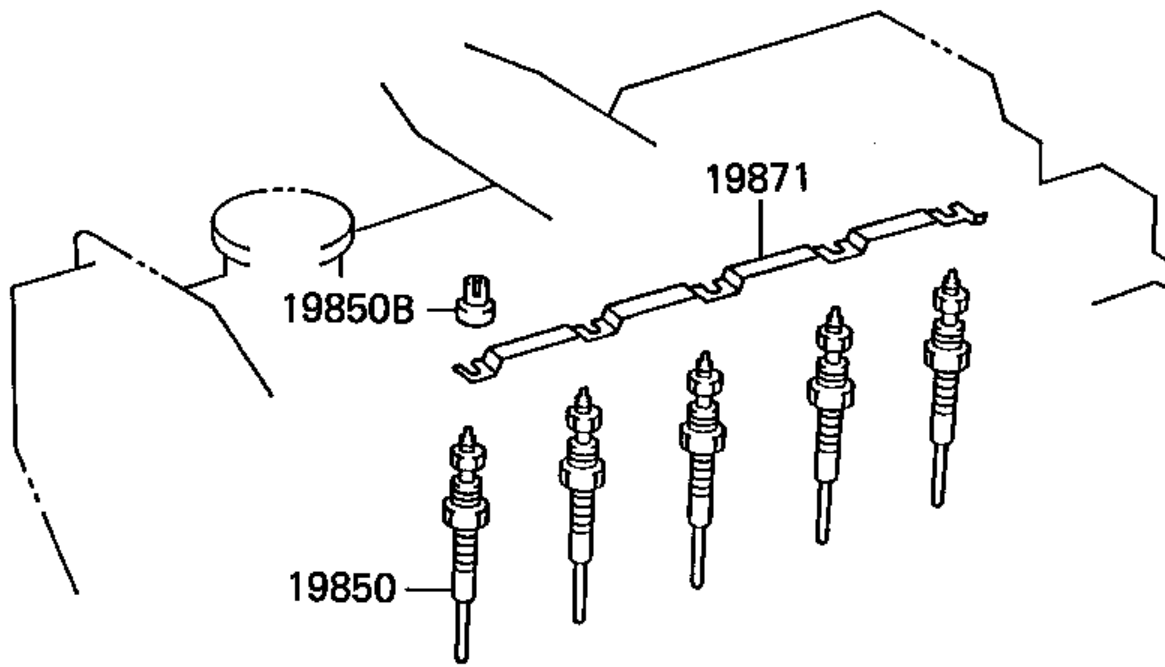

MA D656



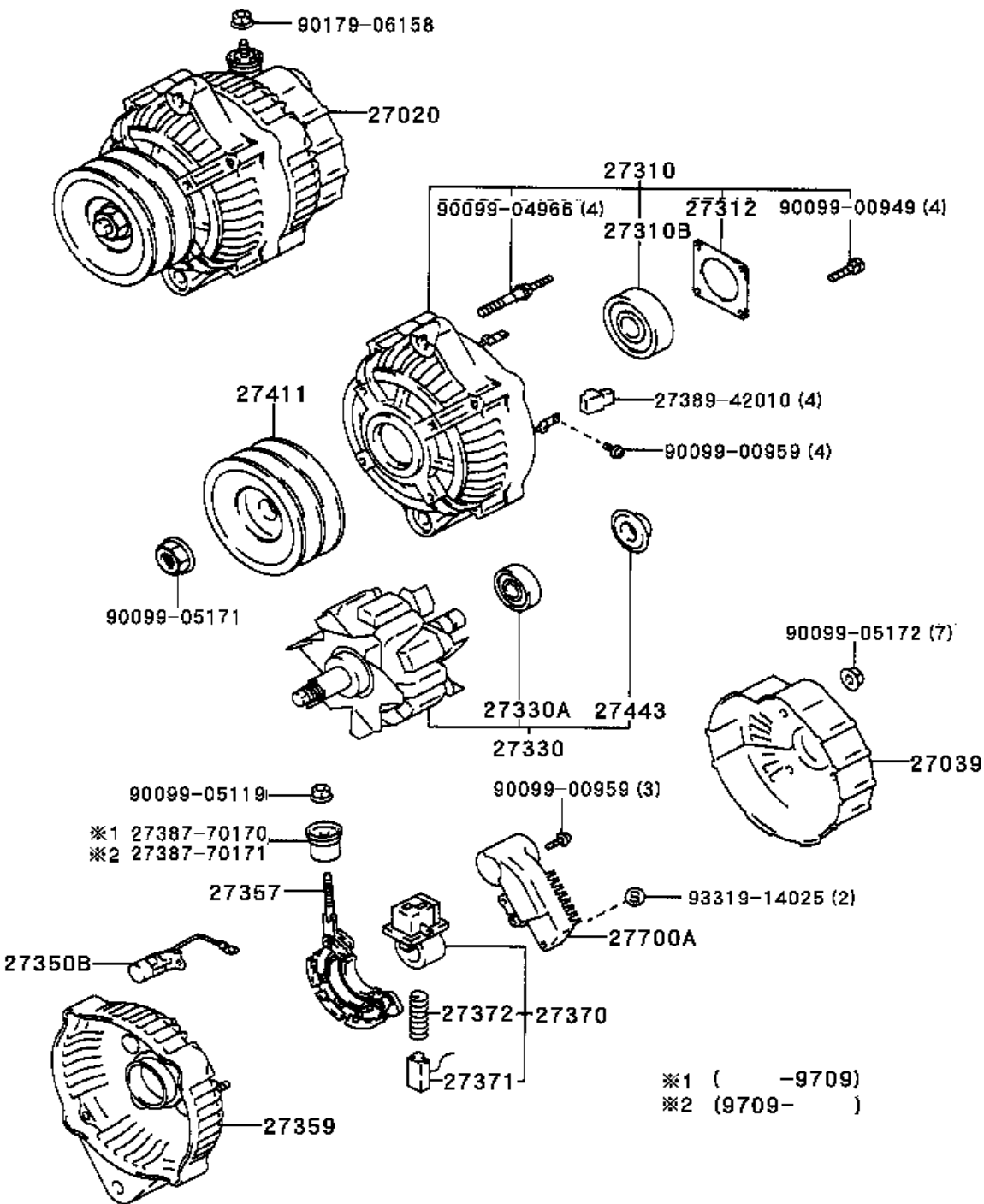

28100

- ※3 94512-01200
- ※4 94612-11200
- ※3 94115-51200
- ※4 94130-61200

92136-61240

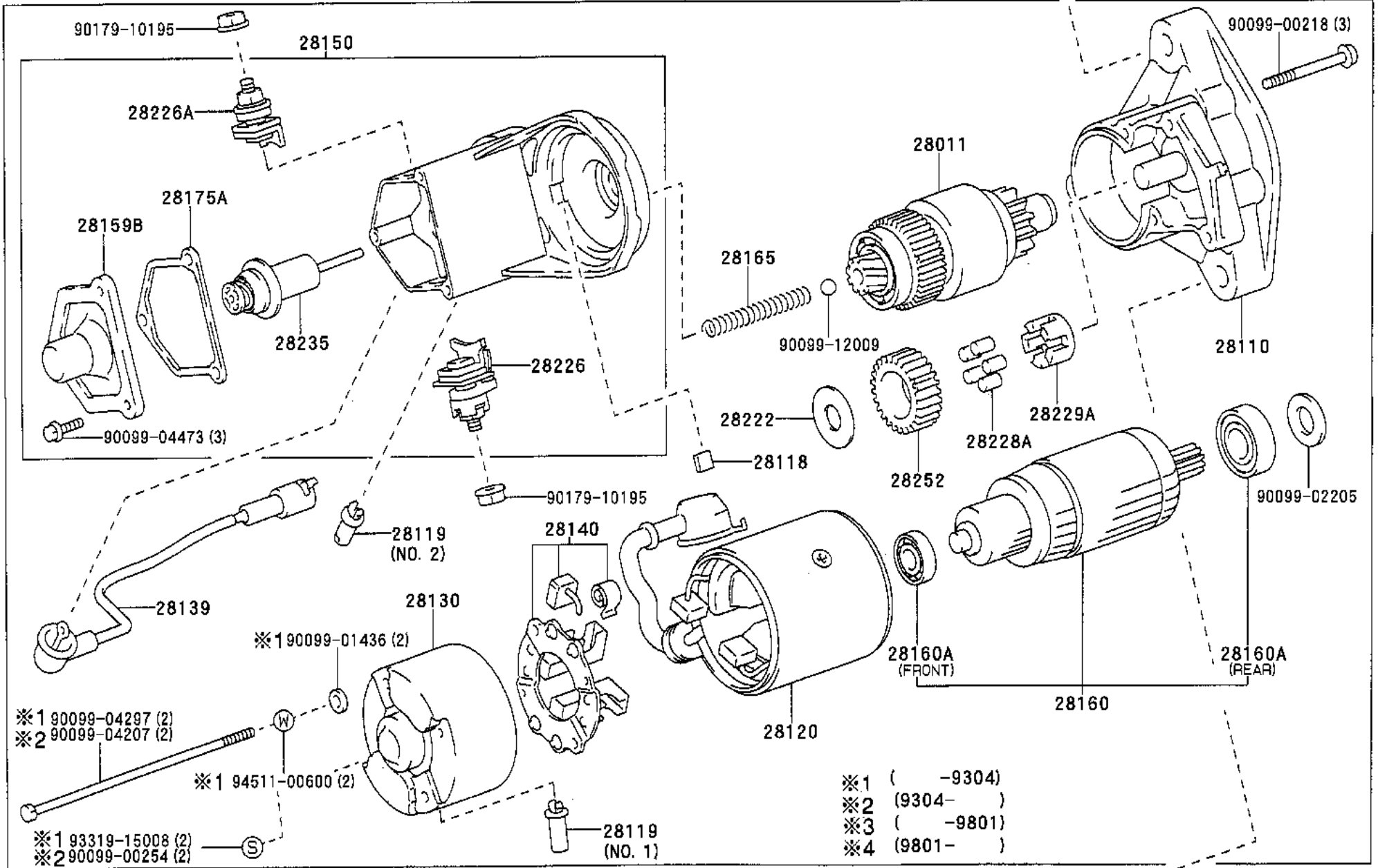

91619-61245

