

(-7901)

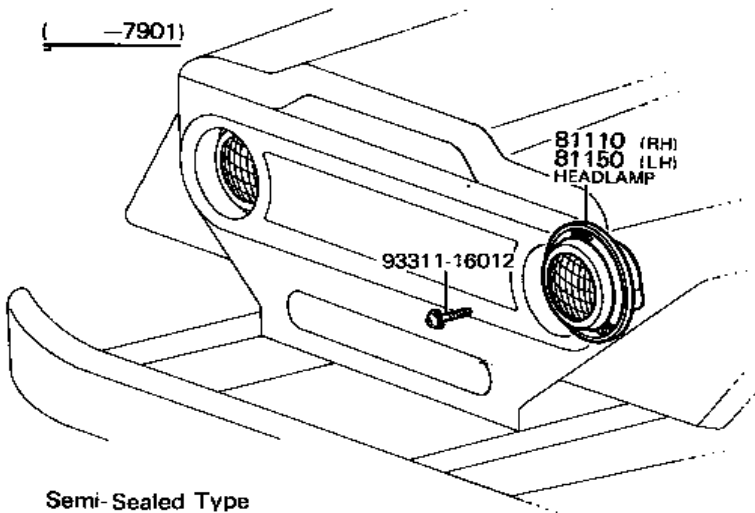

(7901-)

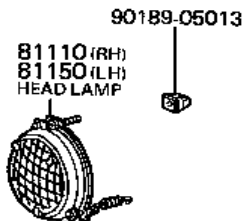

Semi-Seated Type

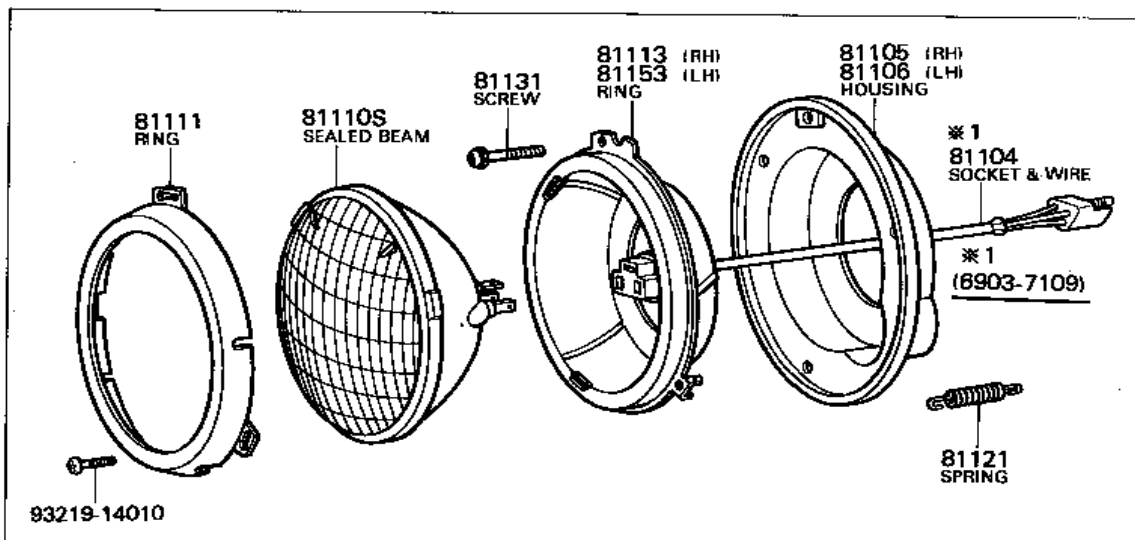
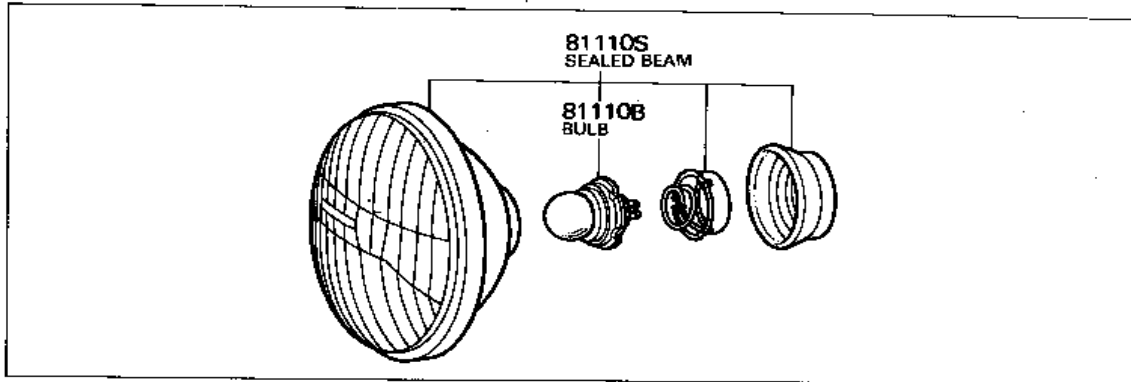

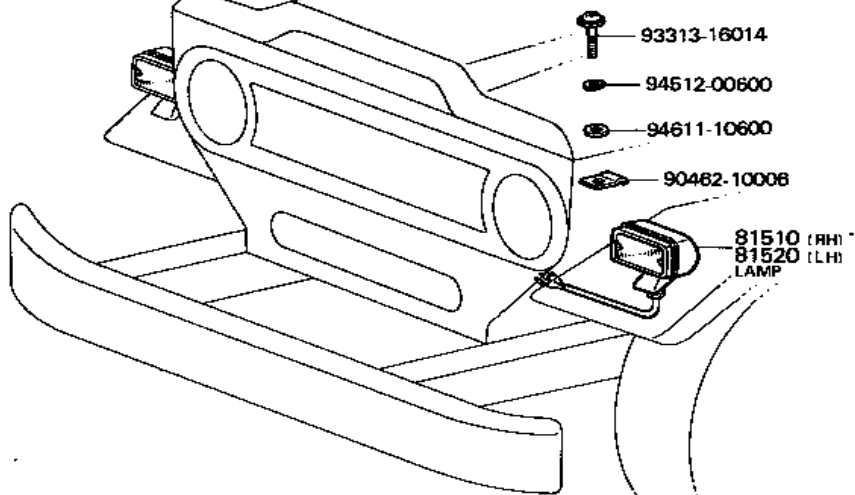

Spec. NO.	①	②
Domestic	Turn & Clearance 12V 23/8W	Parking 12V 3.4W
Export	↑	—

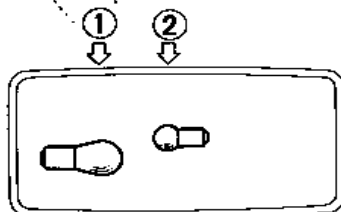

Ⓓ 国内用
For Domestic

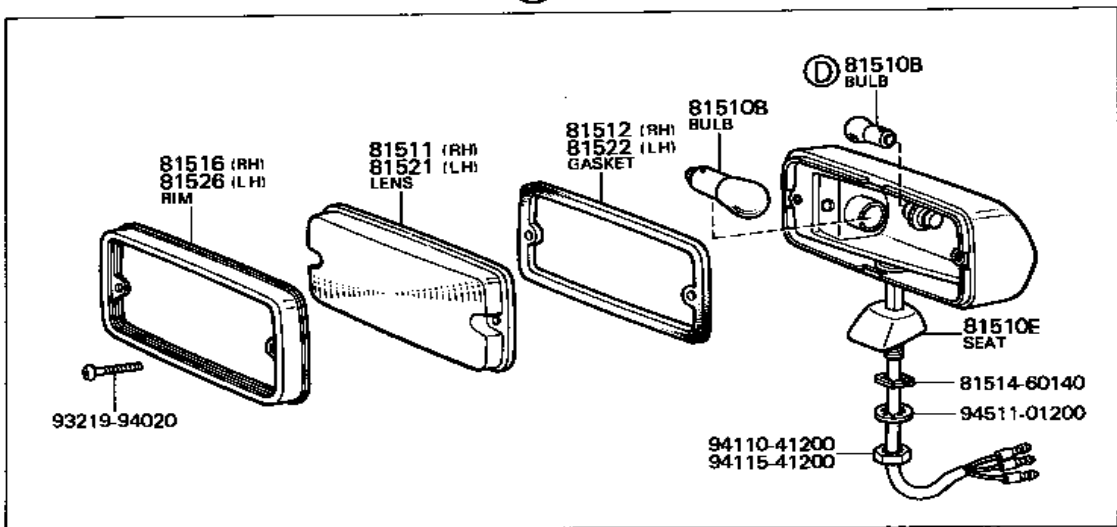

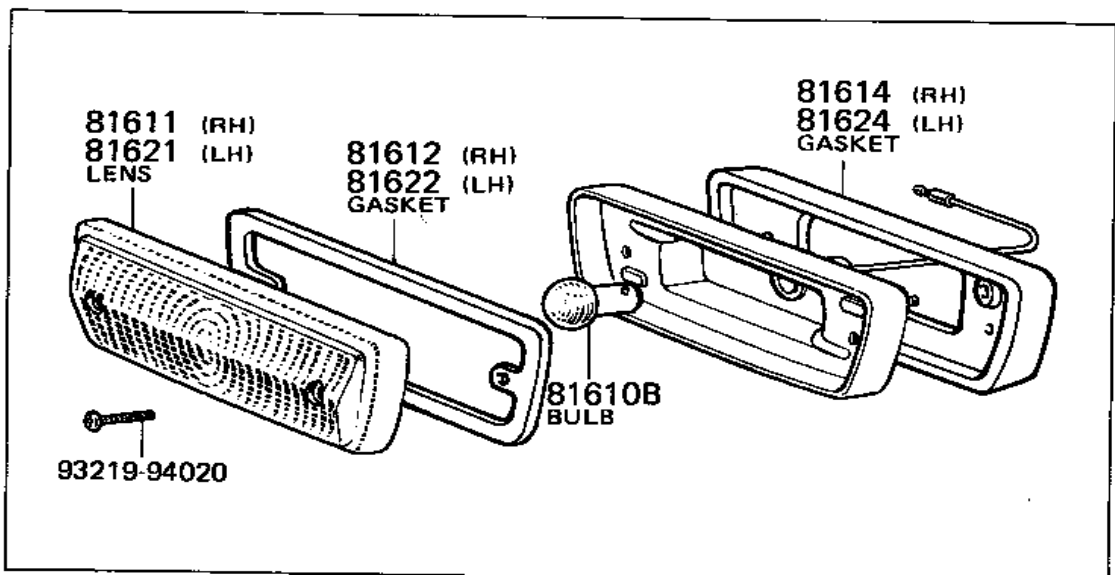
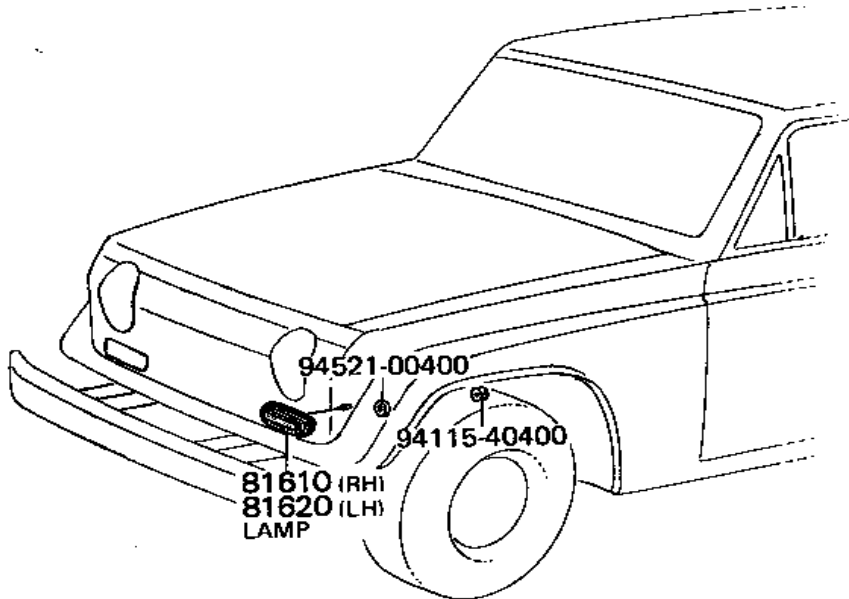

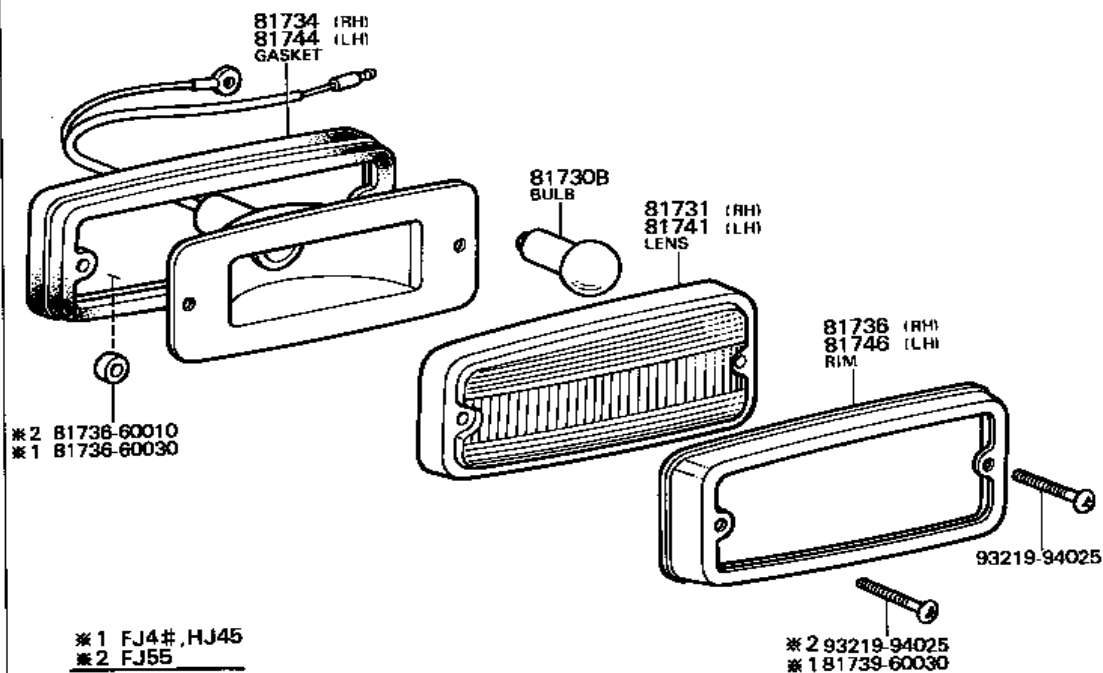
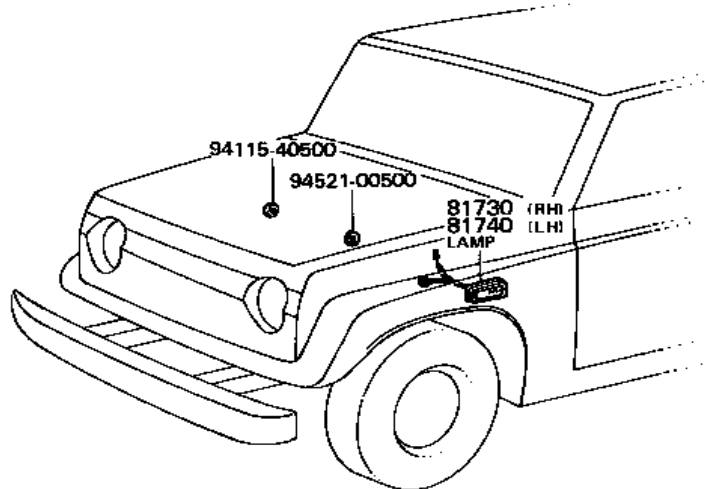

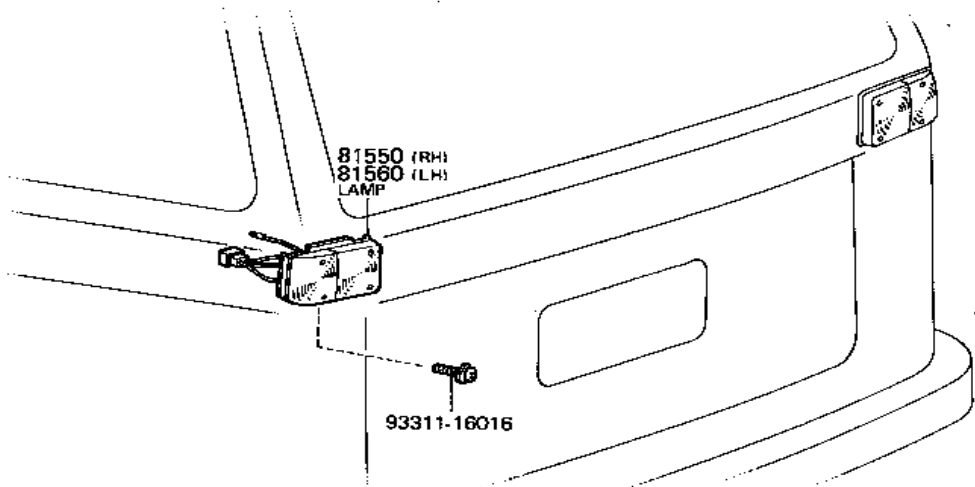

※ (7309-7709)

Spec. \ NO.	①	②	③
Domestic	Turn 12V 23W	Stop & Tail 12V 23/8W	Parking 12V 3.4W
Export	↑	↑	—
※ ECE & Australia	Turn 12V 21W	Stop & Tail 12V 21/5W	—

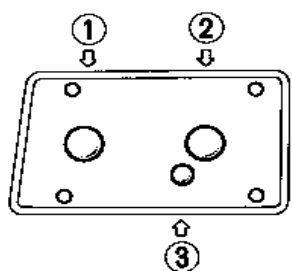

ⓓ 国内用
For Domestic

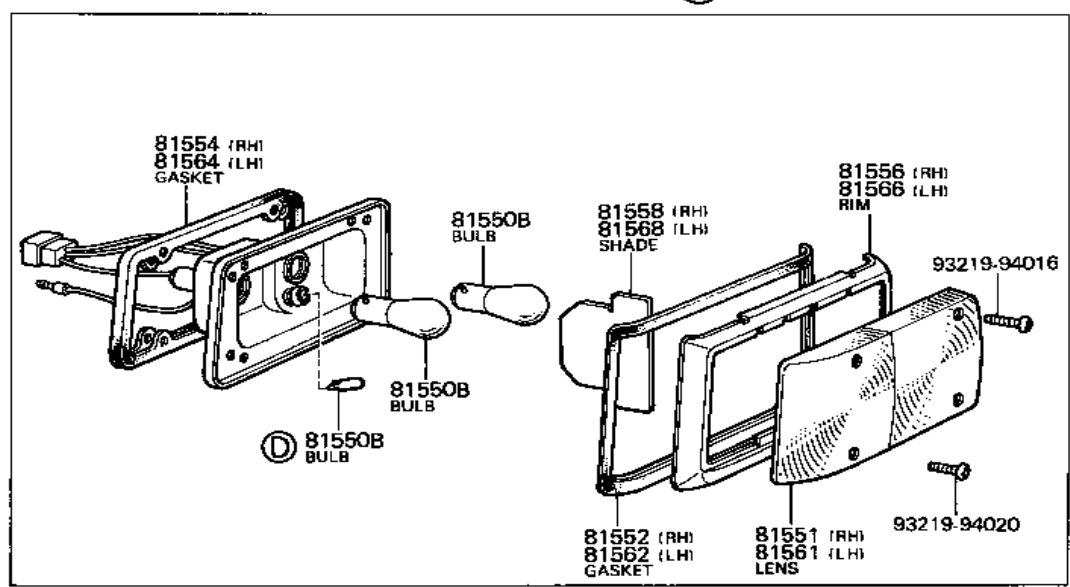

FJ40,42,43

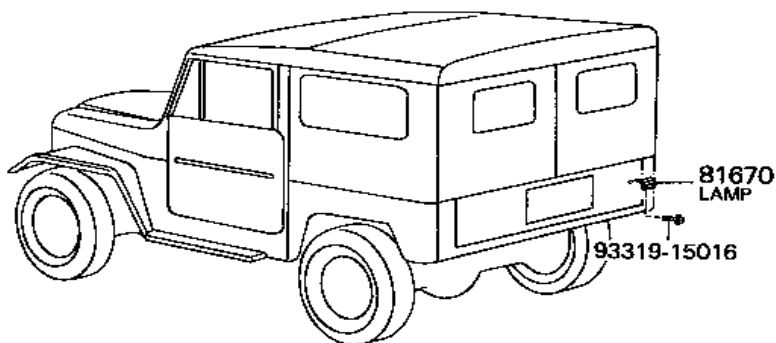

FJ55

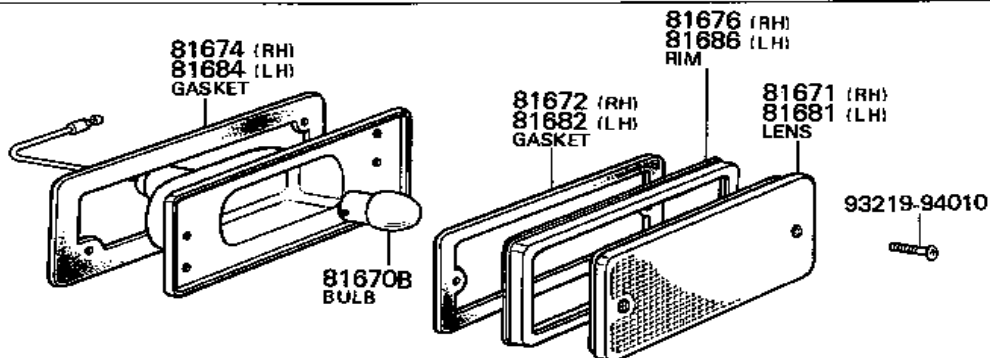
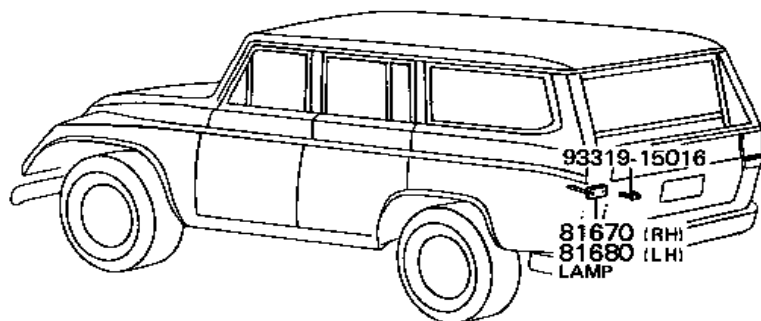

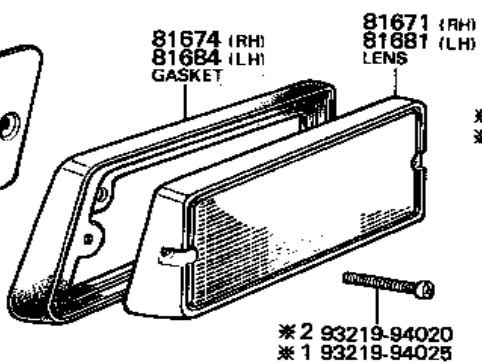
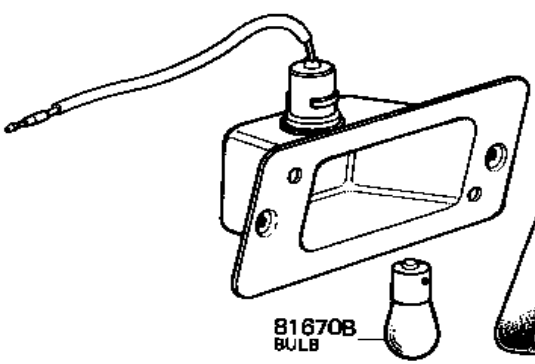
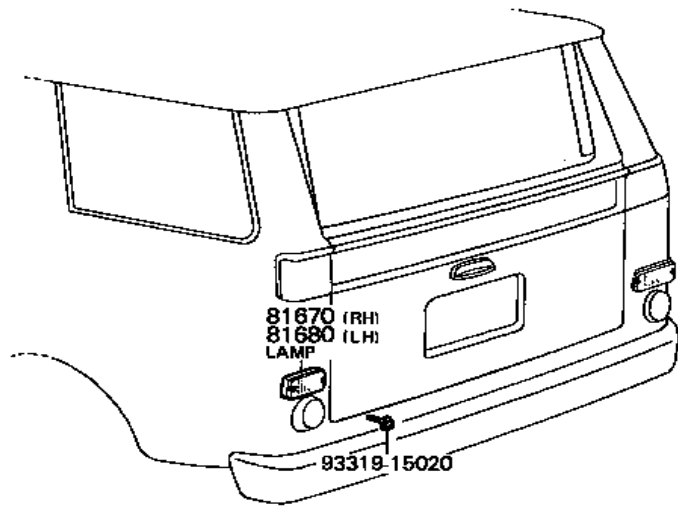

* 1 93219-94016
* 2 93219-94020

* 1 Domestic
* 2 Export

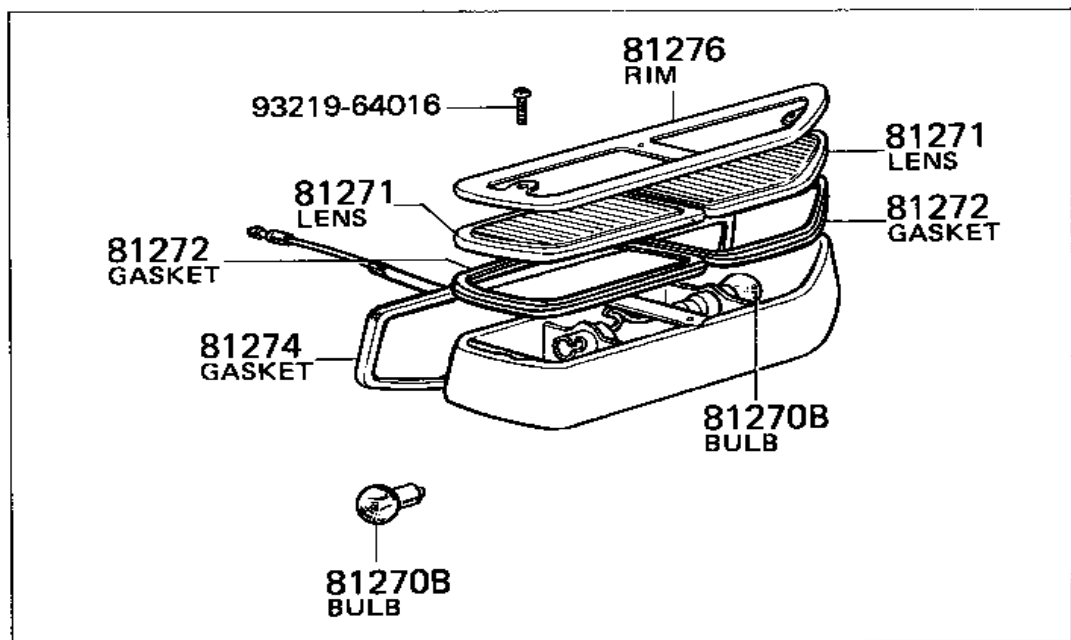
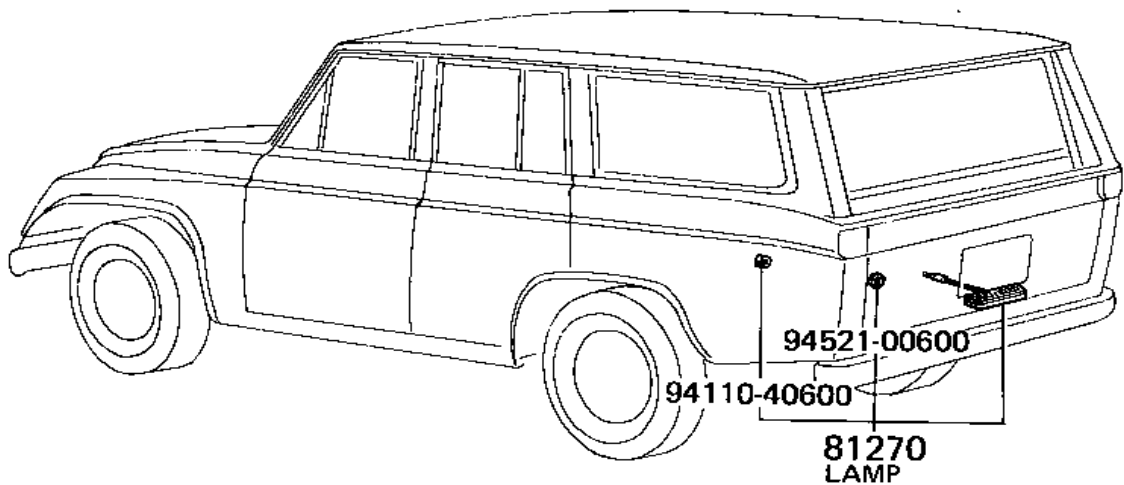

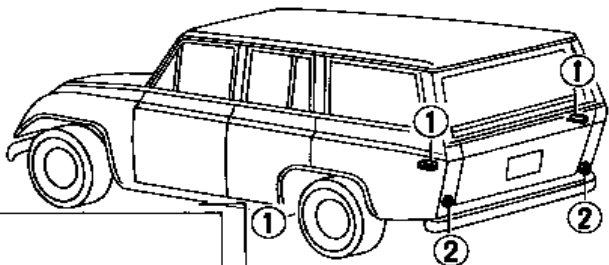

81910 (RH)
81920 (LH)
REFLECTOR

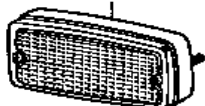

②

(6903-7109)

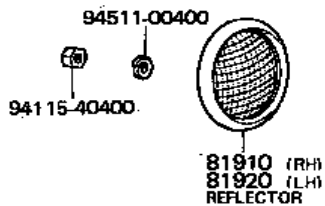

(7109-7709)

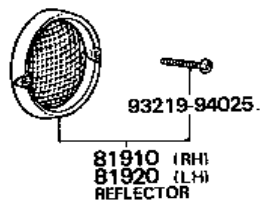

Australia Spec. (7109-7709)

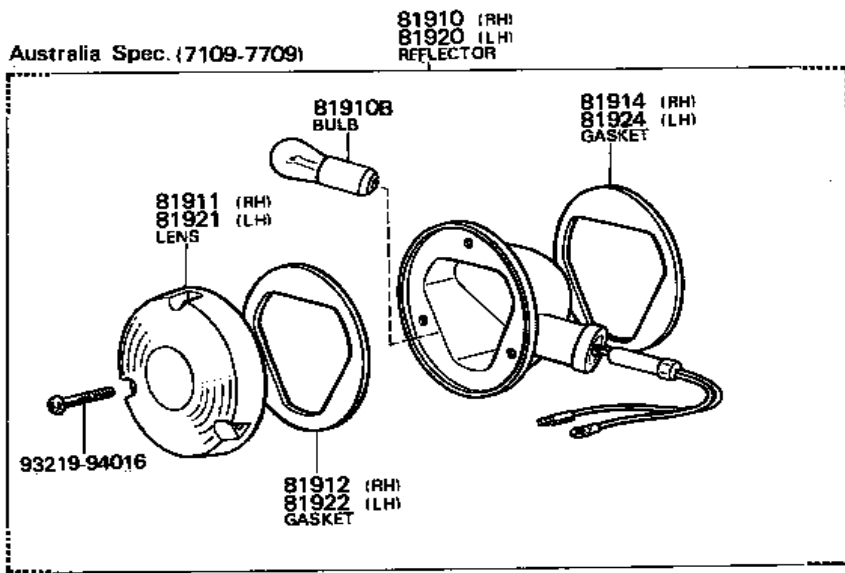

FJ40,42,43..TP

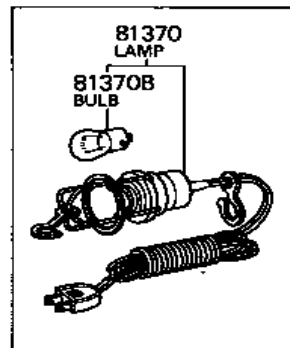
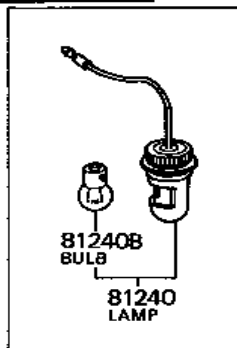
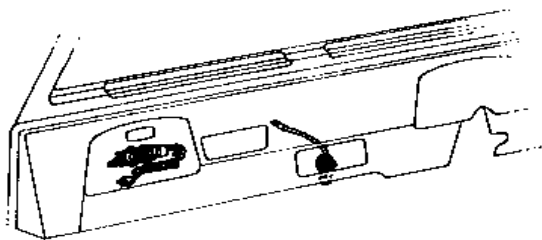

FJ40..V

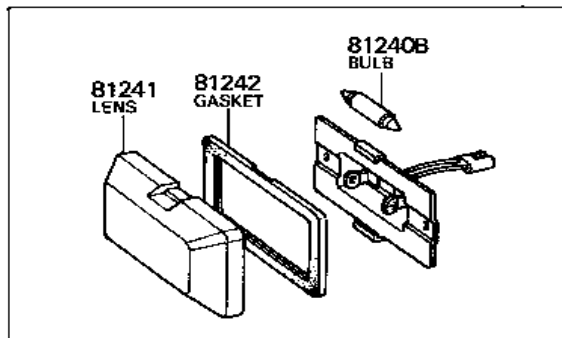
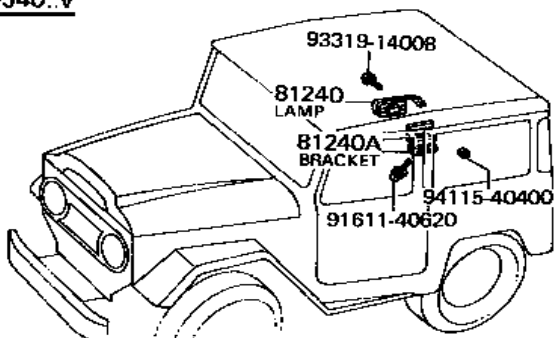

FJ55

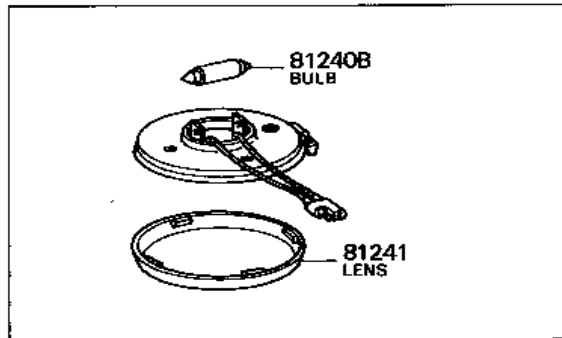
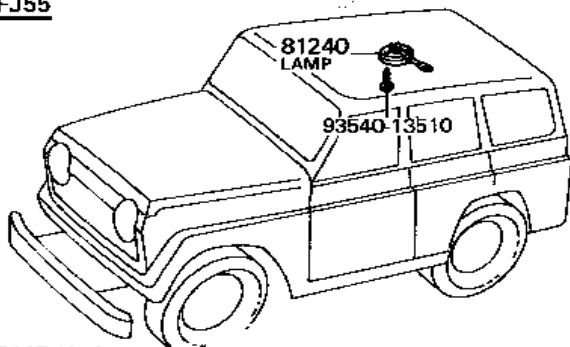

FJ45,HJ45

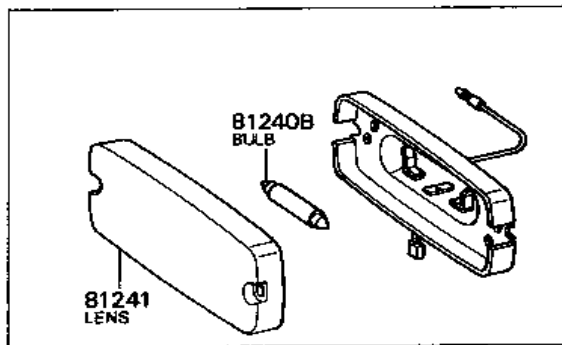
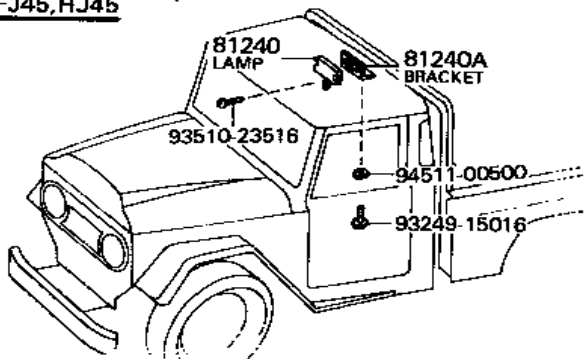

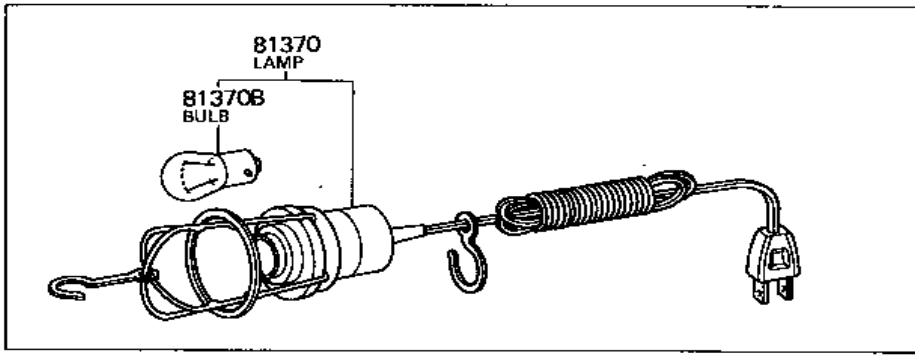

FJ5 #

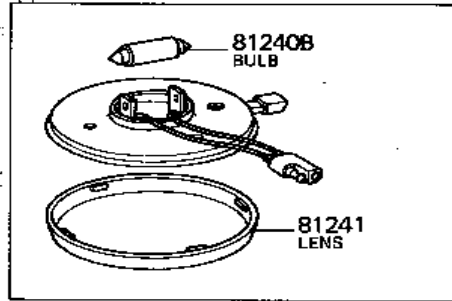
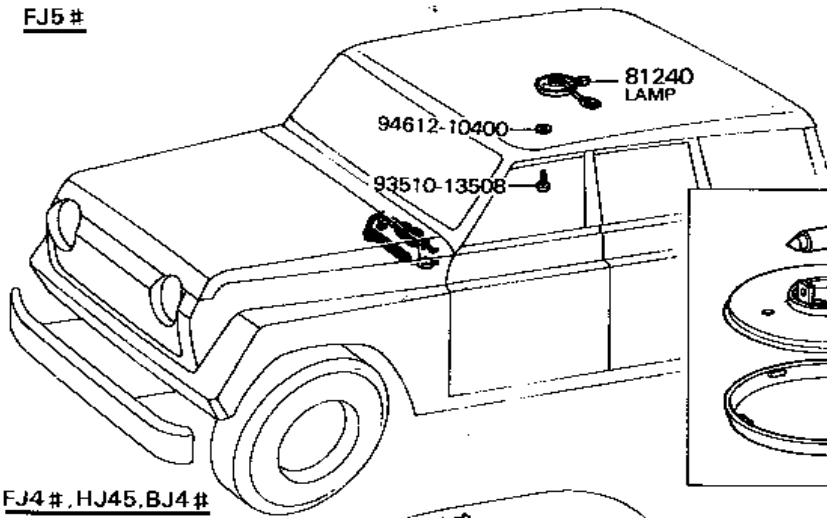

FJ4 #, HJ45, BJ4 #

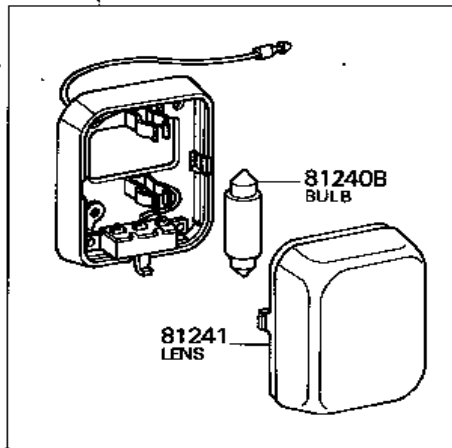
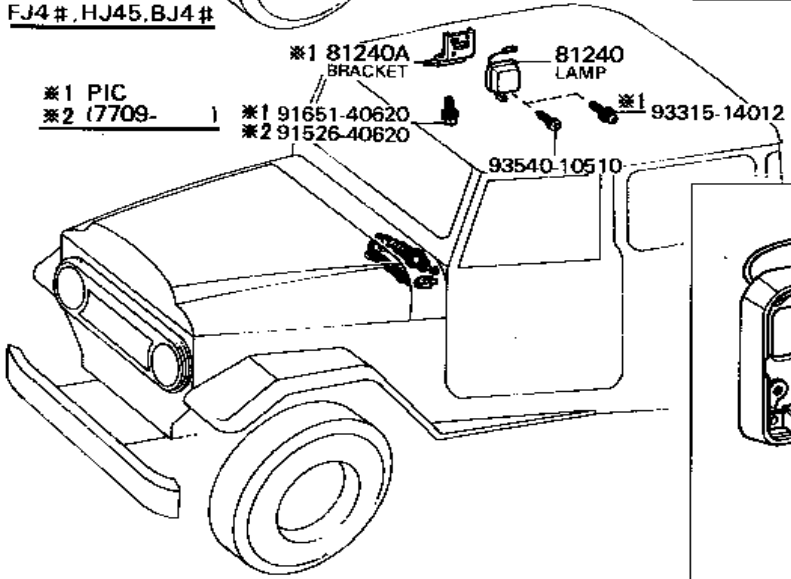

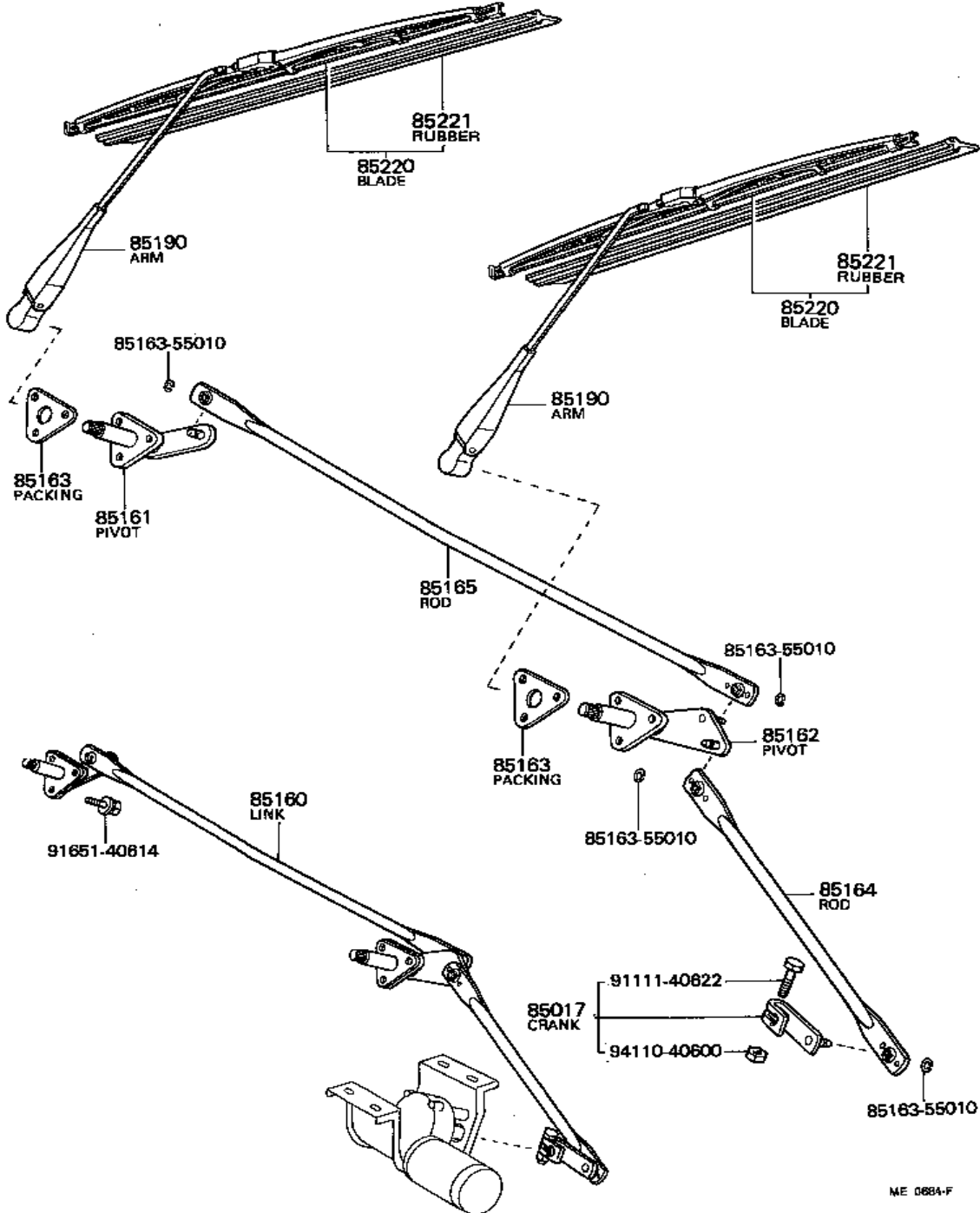

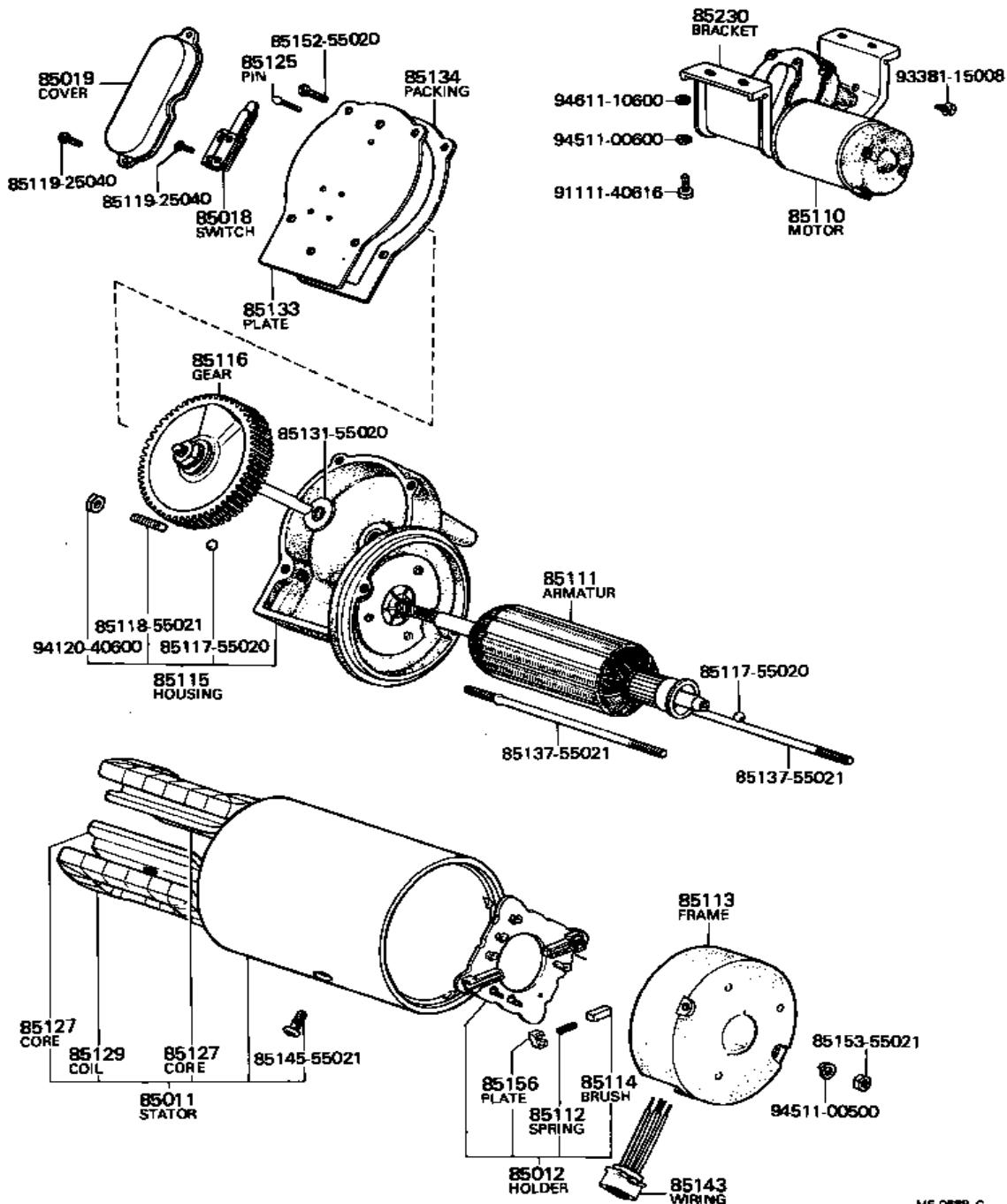

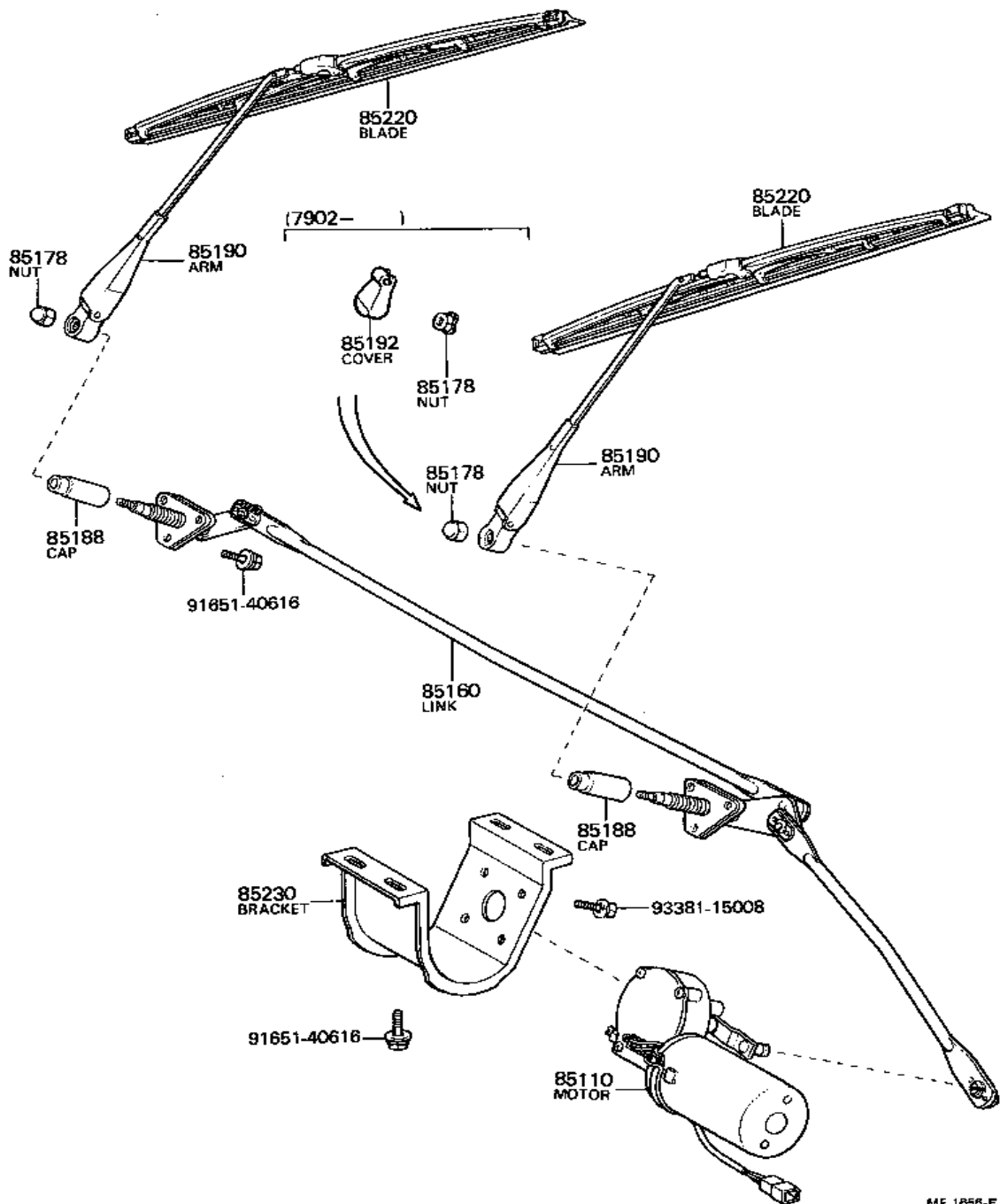

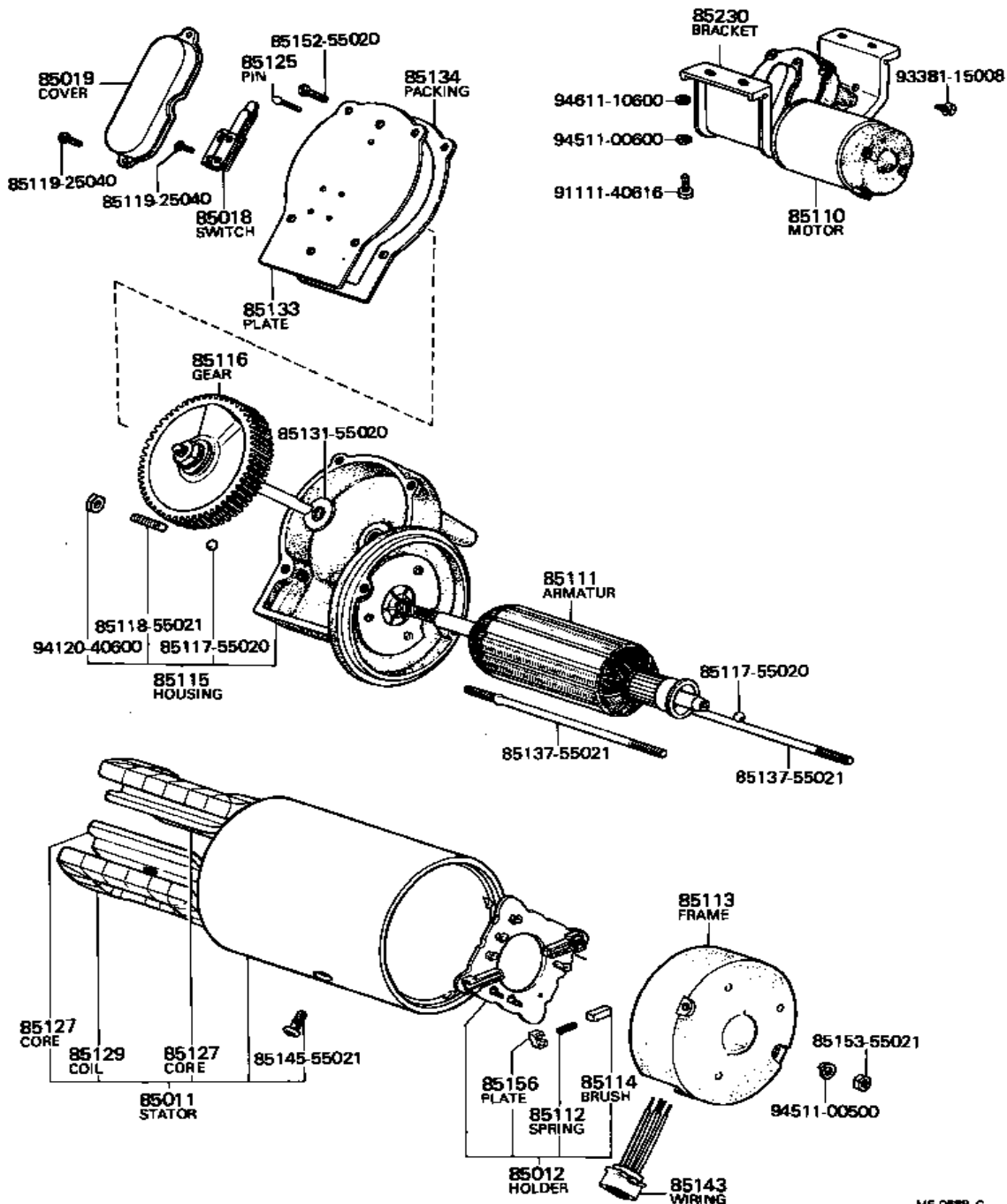

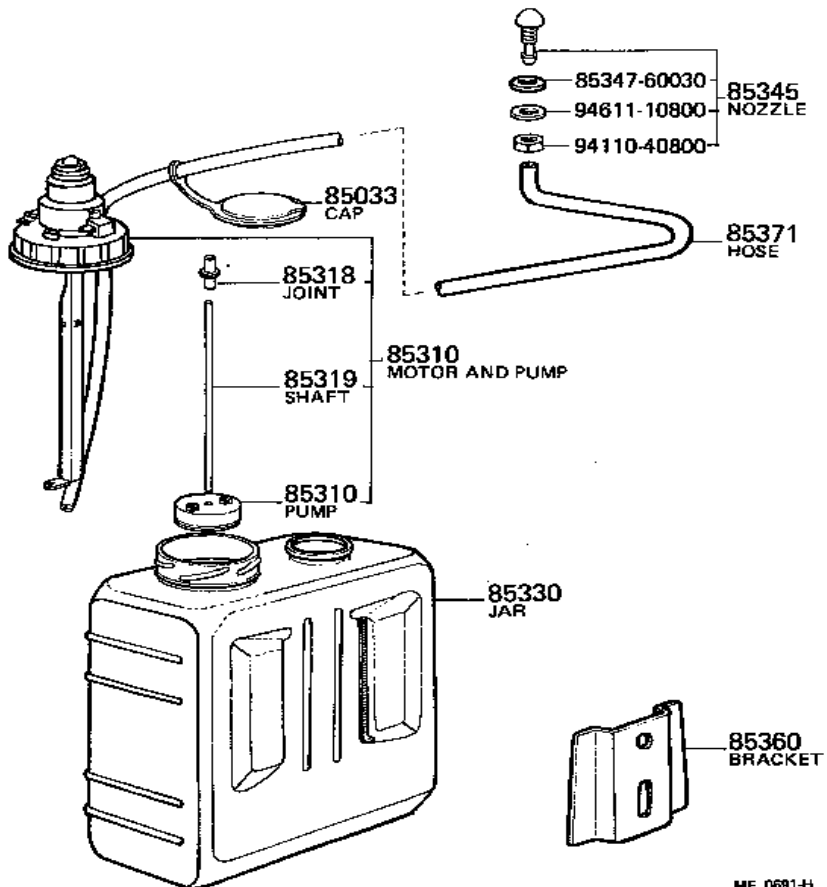
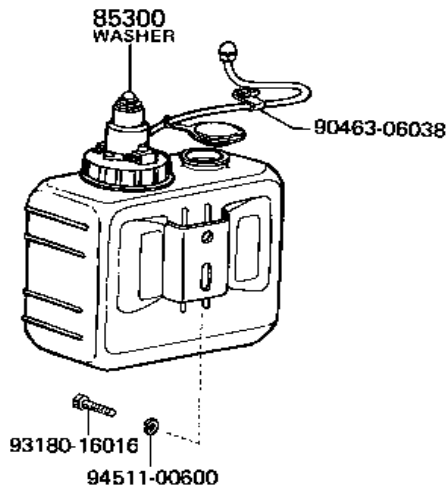

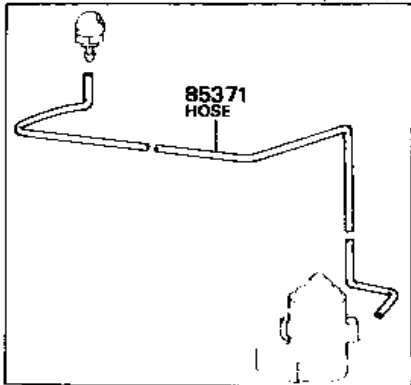

※1 12V System
※2 24V System

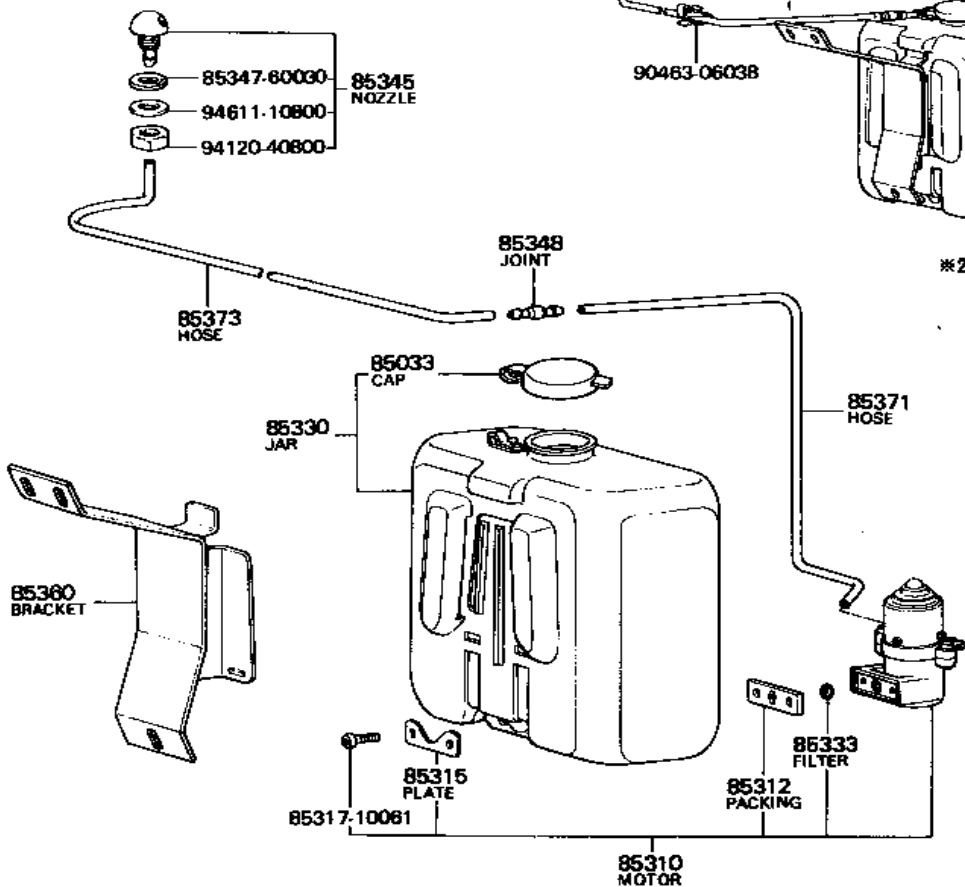
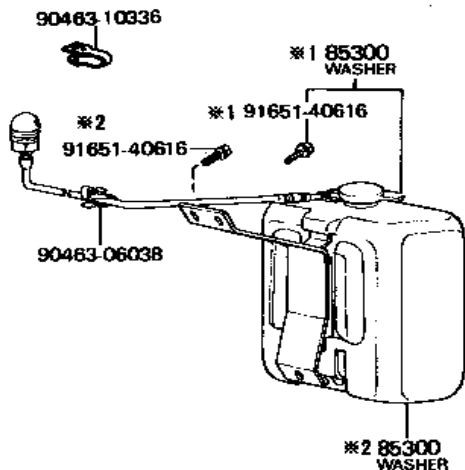

FJ55(6903-7301)

FJ4#, HJ45, BJ4#.FJ5#(7209-)

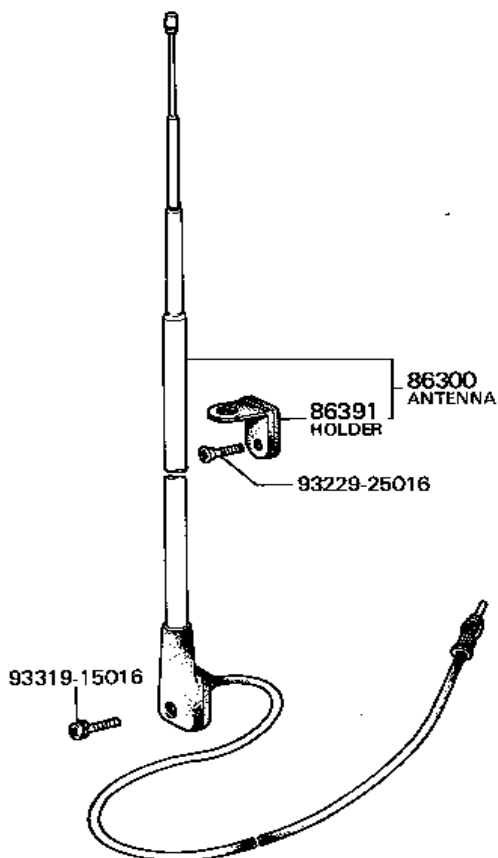
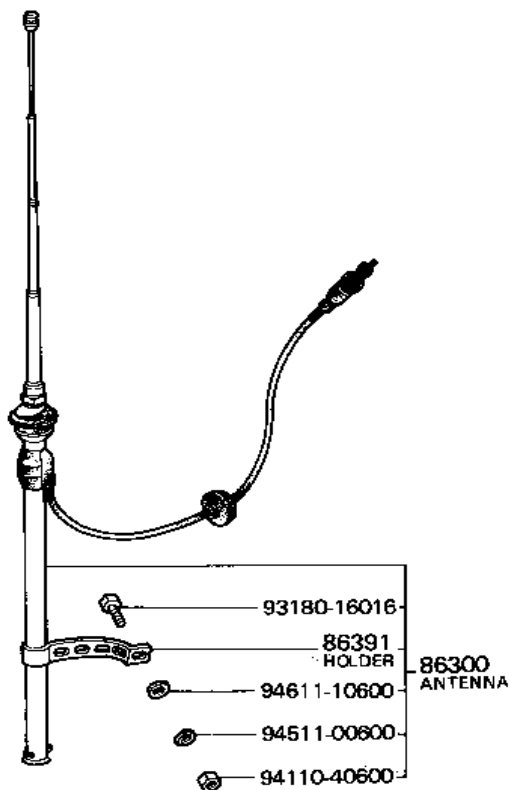

FJ4#,HJ45,BJ4#(7901-)

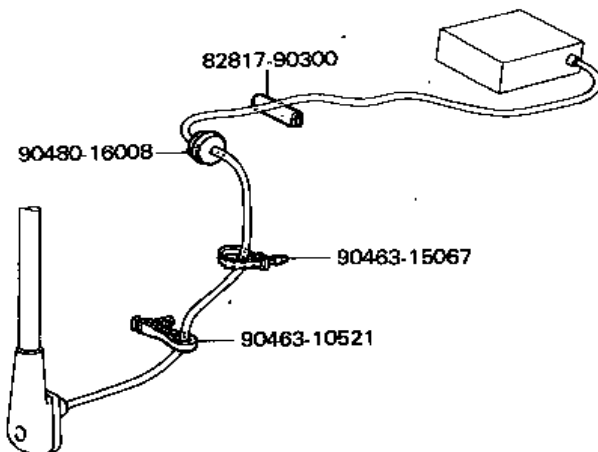

(6903-6910)

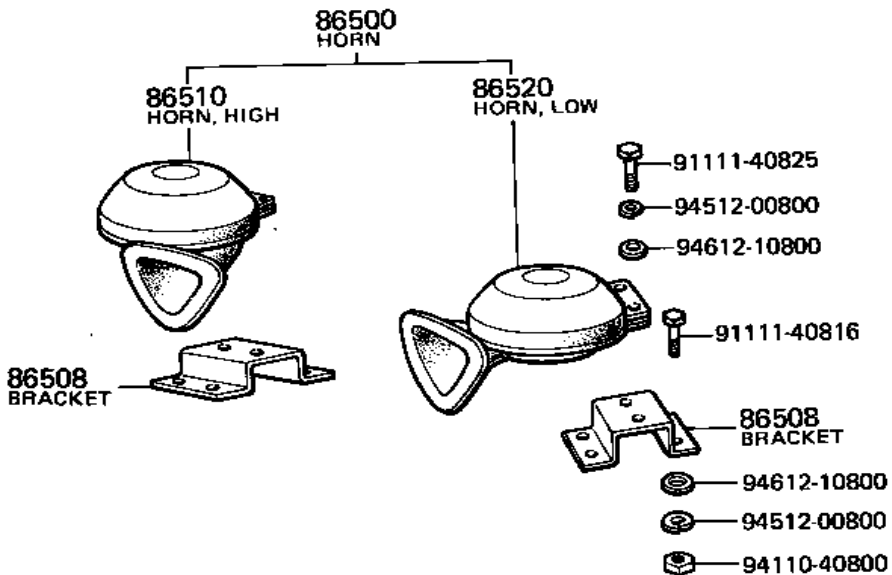

(6910-7709)

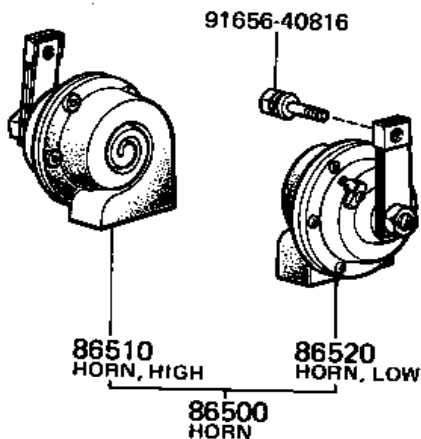

*1 (-7711)
*2 (7711-)

(7709-)

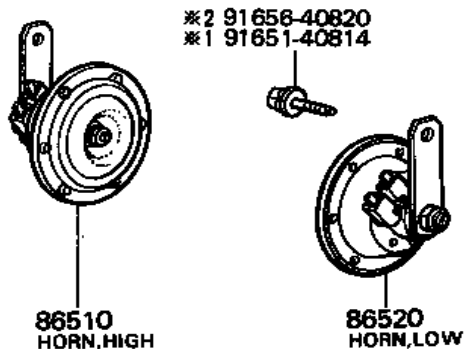

FJ4#, HJ45, BJ4# (-7709)

※1 W/Breakaway Type (脱落式)
 ※2 L/Breakaway Type (非脱落式)

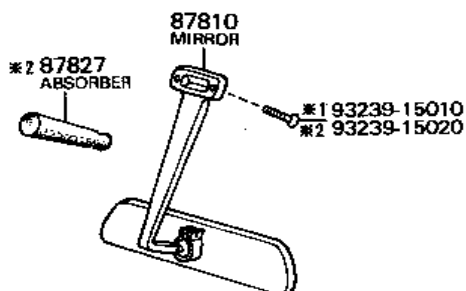

FJ55 (-7709)

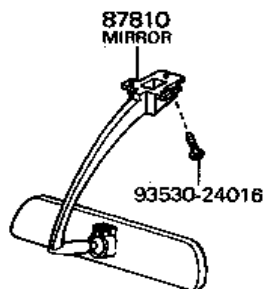

FJ4#, HJ45, BJ4#

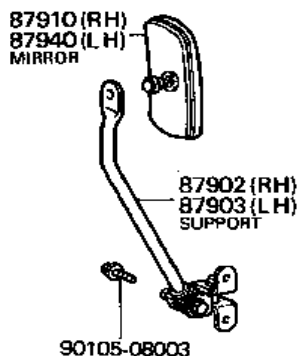

FJ55

(7312-7709)

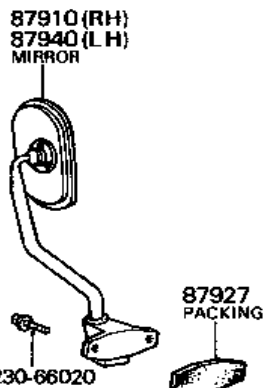

(6903-7312)

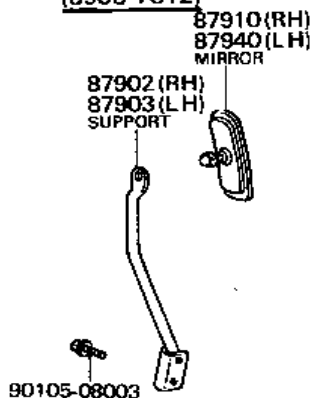

FJ4#, HJ45, BJ4# (7608-)
 FJ55 (7709-)

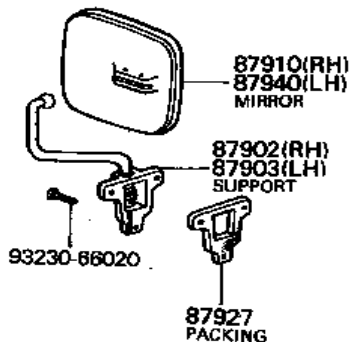

FJ55..Australia

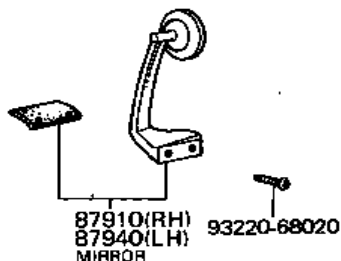

FJ4#, HJ45, BJ4#..Australia

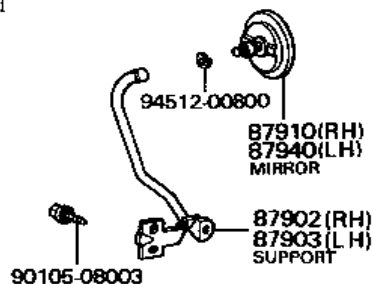

FJ4#, HJ45, BJ4# (6903-)

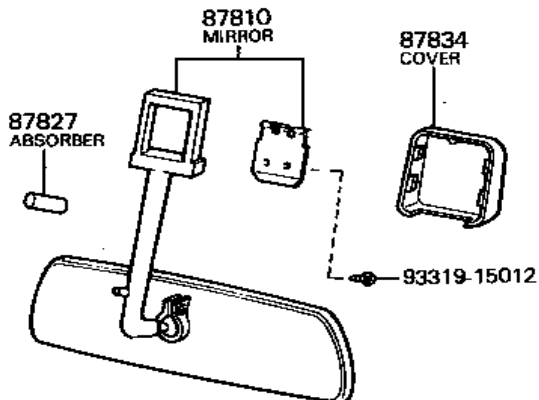

FJ55

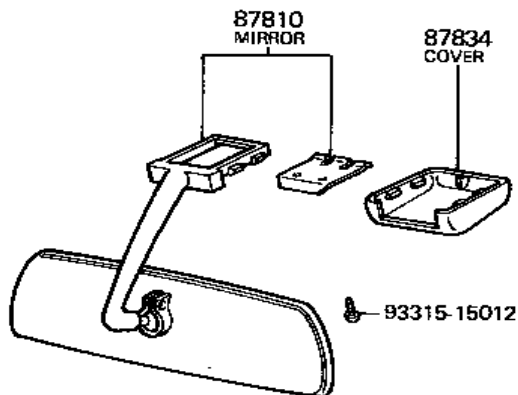

FJ4#, HJ45, BJ4# .EUR (6903-)

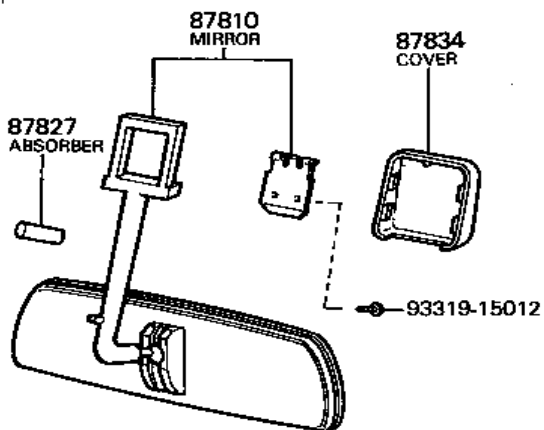

FJ55 .EUR, ARL

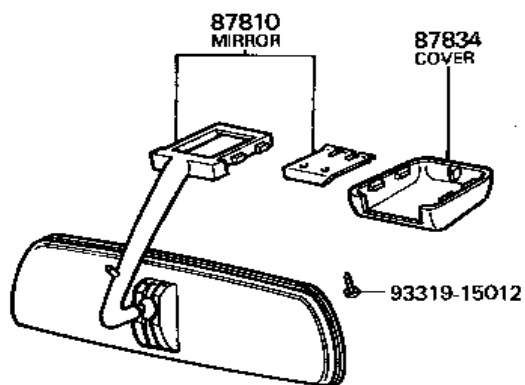

FJ4#, HJ45, BJ4# .EUR

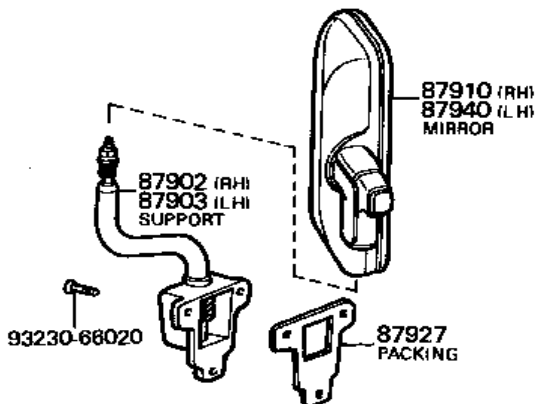

FJ55 .EUR

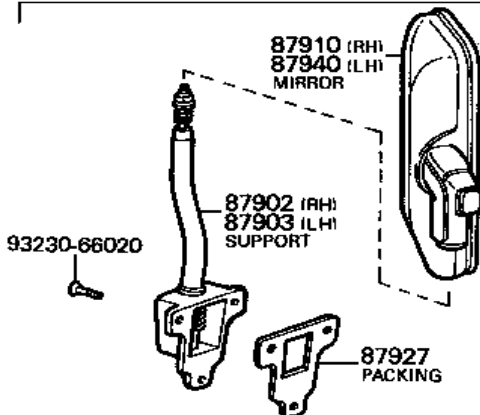

W/ELECTRICAL WINCH

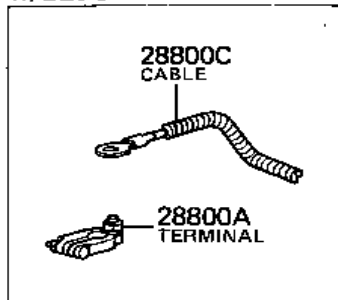

FJ4 # (6903-7001)

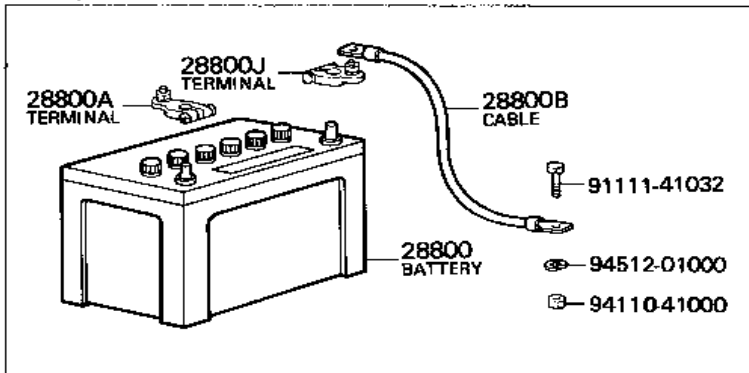



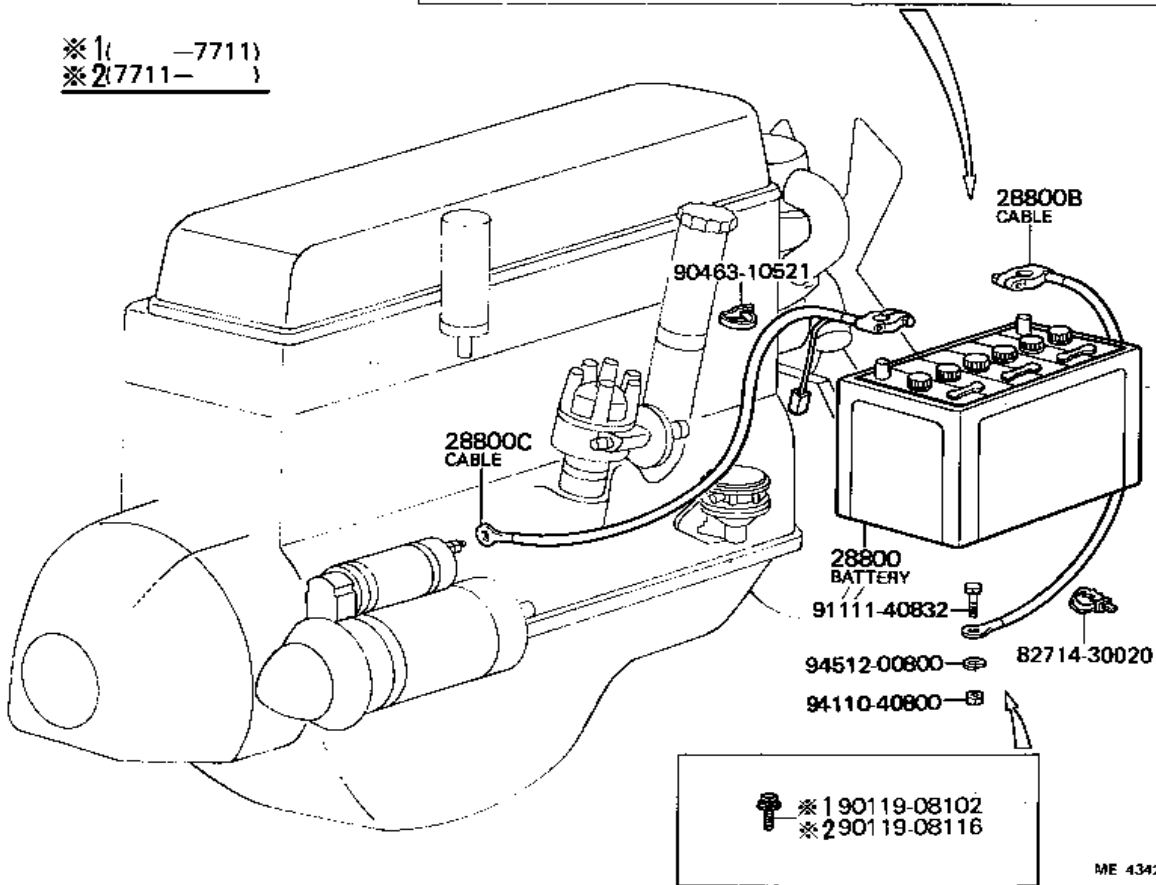

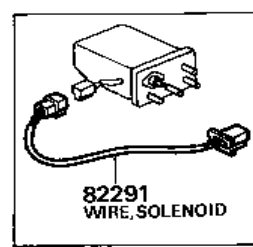
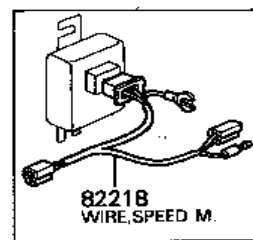
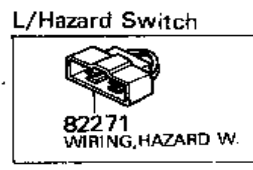
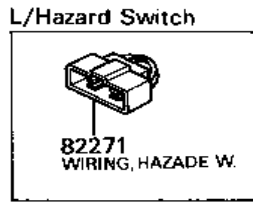
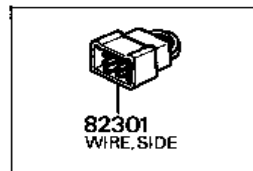
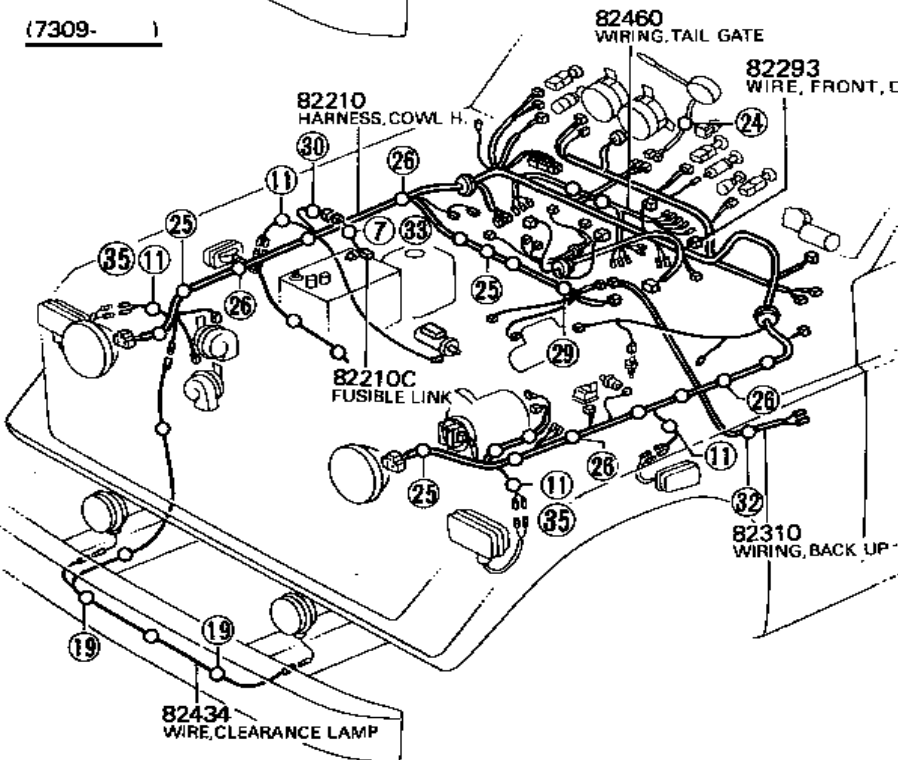
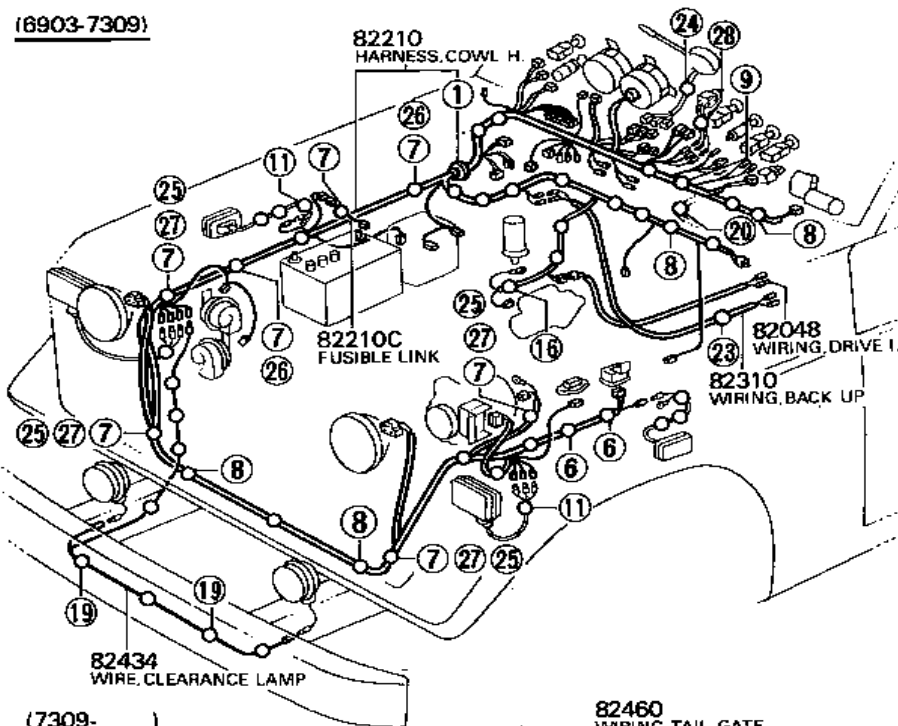

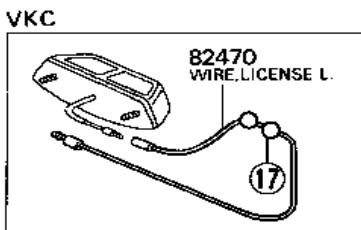
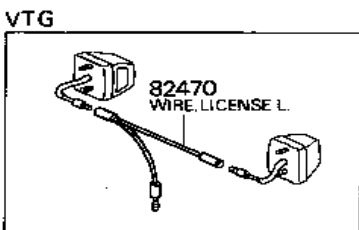
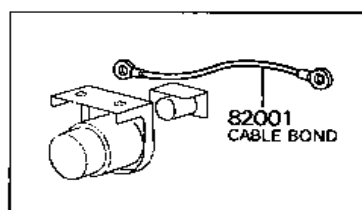
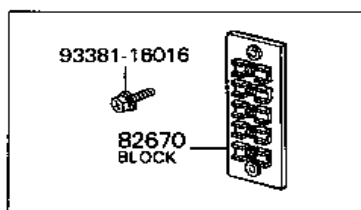
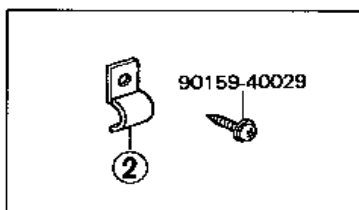
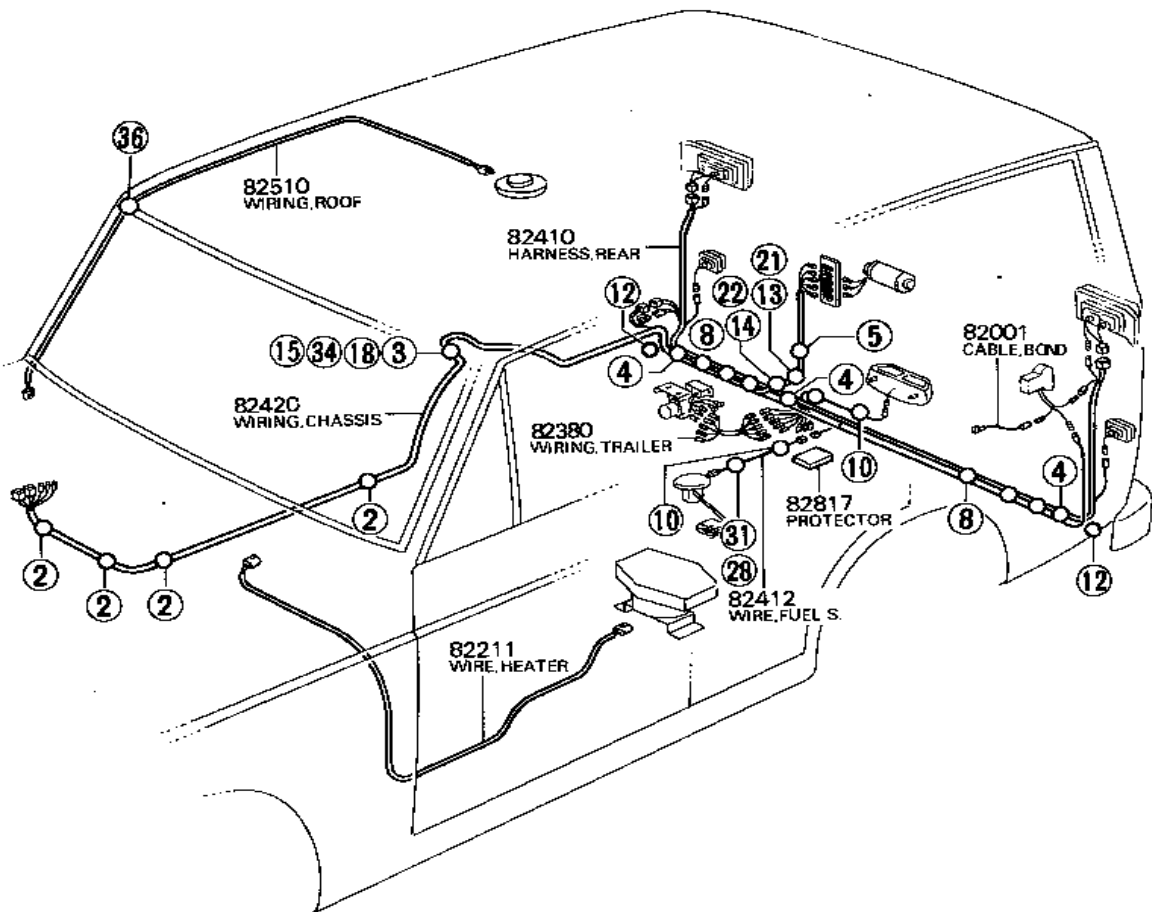









※ 1 (-7711)
 ※ 2 (7711 -)





























NO.	①	②	③	④	⑤	⑥	⑦	⑧
TYPE								
PART NO.	82819-20010	90462-10126	90480-15045	90480-19048	90480-23021	82714-30020	82714-30010	90483-08075
MODELS	all	all	..VTG	all	..VTG	all	all	all
PROD.DATE	6903-7209	6903-	6903-7109	6903-7209	6903-7209	6903-7209	6903-7501	7109-7209
QTY.	1	4	1	2	1	4	11	23

NO.	⑨	⑩	⑪	⑫	⑬	⑭	⑮	⑯
TYPE								
PART NO.	90483-08095	90463-06326	90480-15007	90480-40303	90480-25010	65641-90351	90480-36508	90463-08171
MODELS	all	all	all	all	..VTG	..VTG	all	all
PROD.DATE	7109-7209	7109-7209	7109-7701	7109-	7109-7209	7109-7209	7609-	7109-7209
QTY.	4	3	4	2	1	1	1	1

NO.	⑰	⑱	⑲	⑳	㉑	㉒	㉓	㉔
TYPE								
PART NO.	90480-10300	90480-27022	90463-08030	90480-30325	90480-01316	82819-90350	90461-08852	90467-36135
MODELS	..VKC	all	For ARL	..RHD	..VTG	..VTG	all	all
PROD.DATE	7109-	7109-7603	7305-7501	7209-7309	7209-7309	7209-	7209-7309	7209-
QTY.	2	1	5	1	1	1	1	1

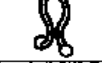
NO.	㉕	㉖	㉗	㉘	㉙	㉚	㉛	㉜
TYPE								
PART NO.	90463-10335	90463-10336	90463-10337	90463-08375	90463-08161	90463-15067	90463-08027	90480-01316
MODELS	all	all	all	all	all	all	all	all
PROD.DATE	7211-	7209-	7209-7211	7209-	7309-	7309-	7309-7701	7309-
QTY.	1	9	1	3	2	4	2	1

NO.	㉝	㉞	㉟	㊱	㊲	㊳	㊴	㊵
TYPE								
PART NO.	90463-04340	90480-29471	90480-15172	90480-18011	90480-14338	90464-00190	90483-10521	
MODELS	all	all	all	all	all	all	FJ55.56	
PROD.DATE	7501-	7603-7608	7701-	7708-	7801-	7803-	7809-	
QTY.	1	1	2	1	1	1	7	

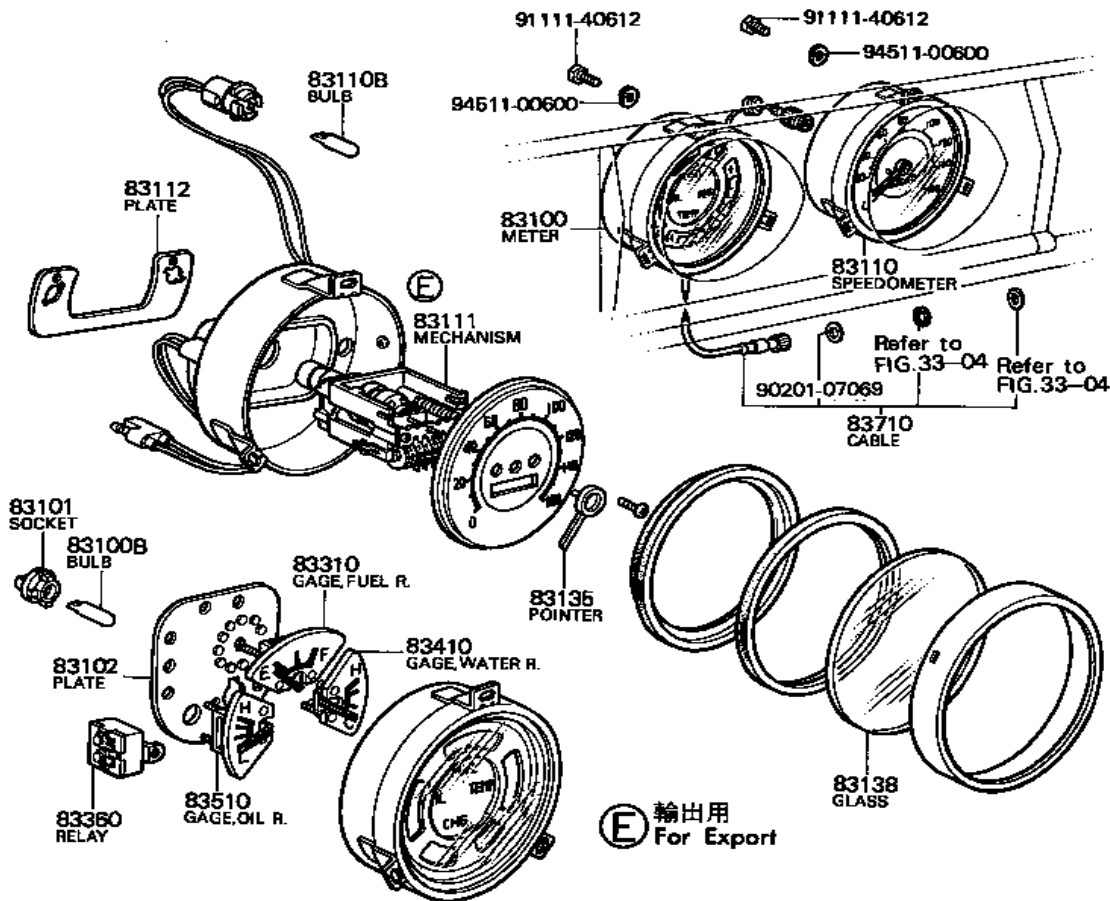

W/Ammeter

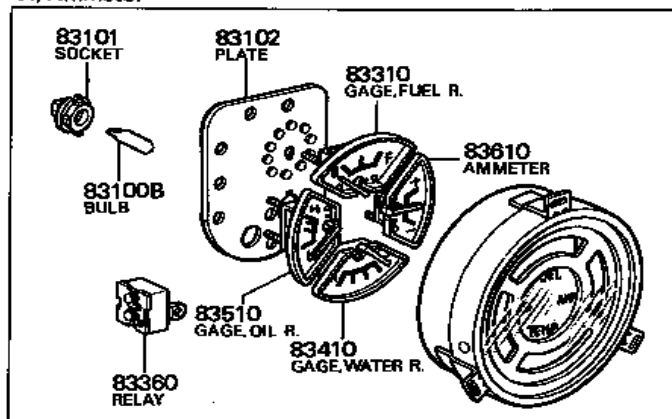

Speedometer Cable Clamp

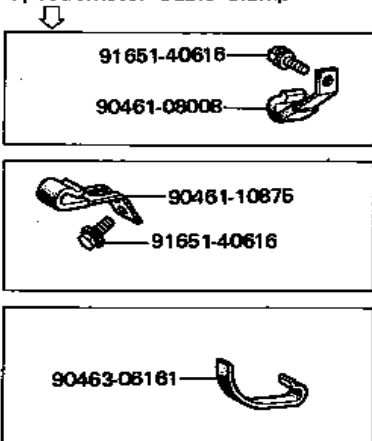

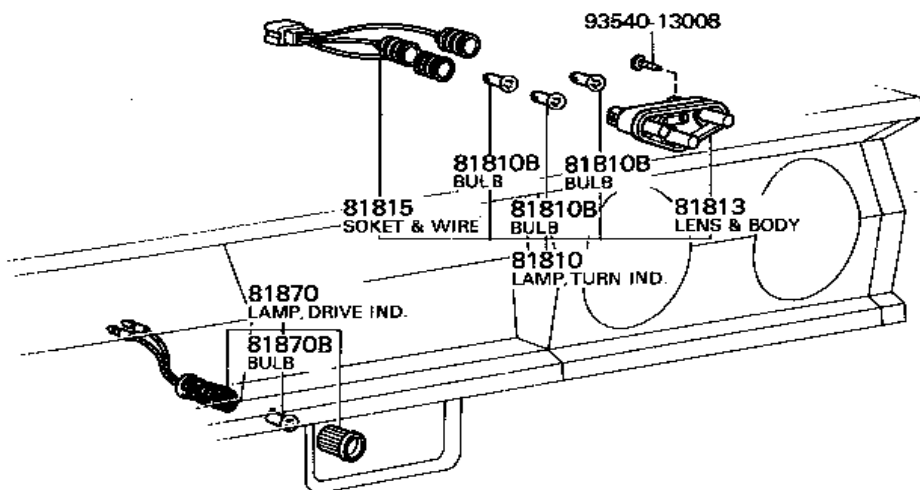
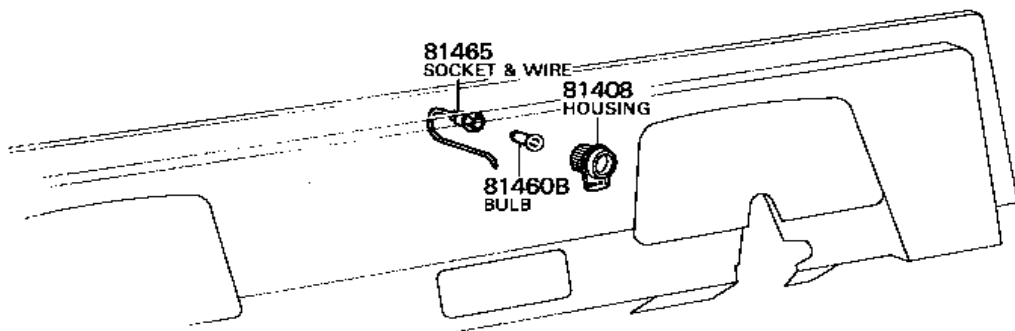
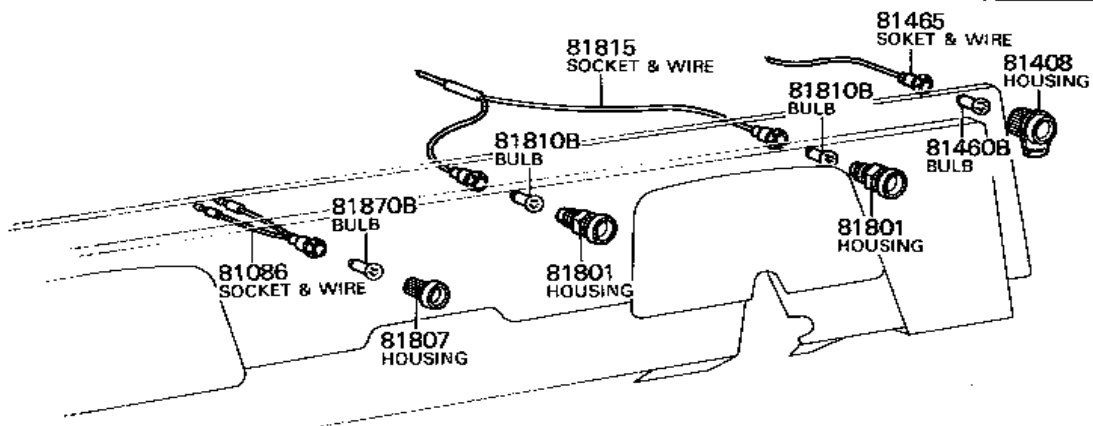

FJ4#, HJ45

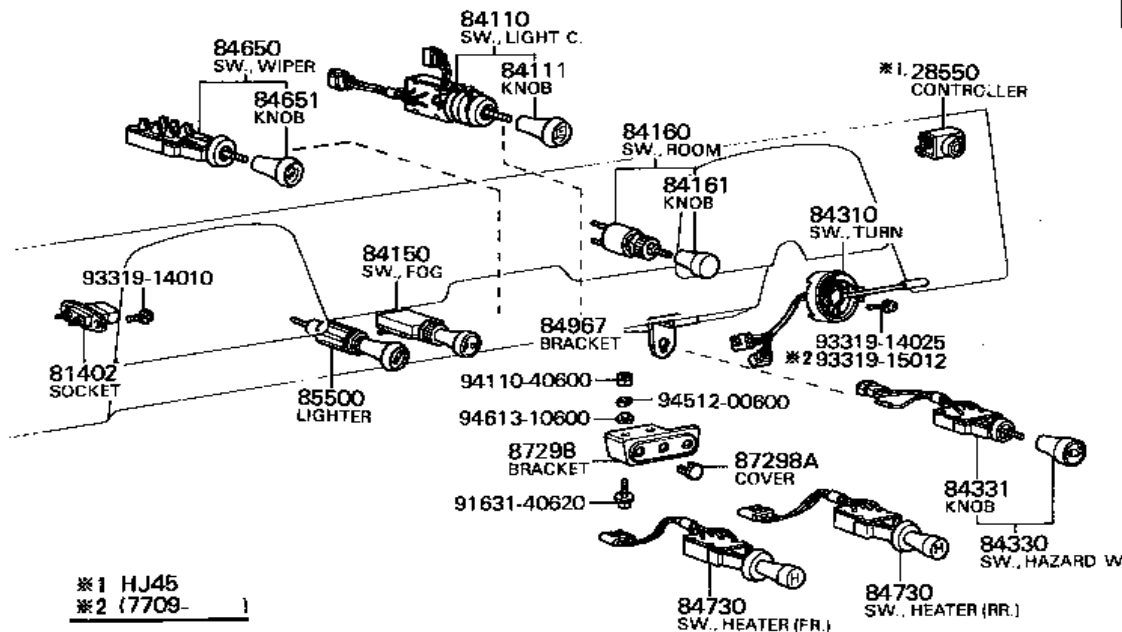

FJ55

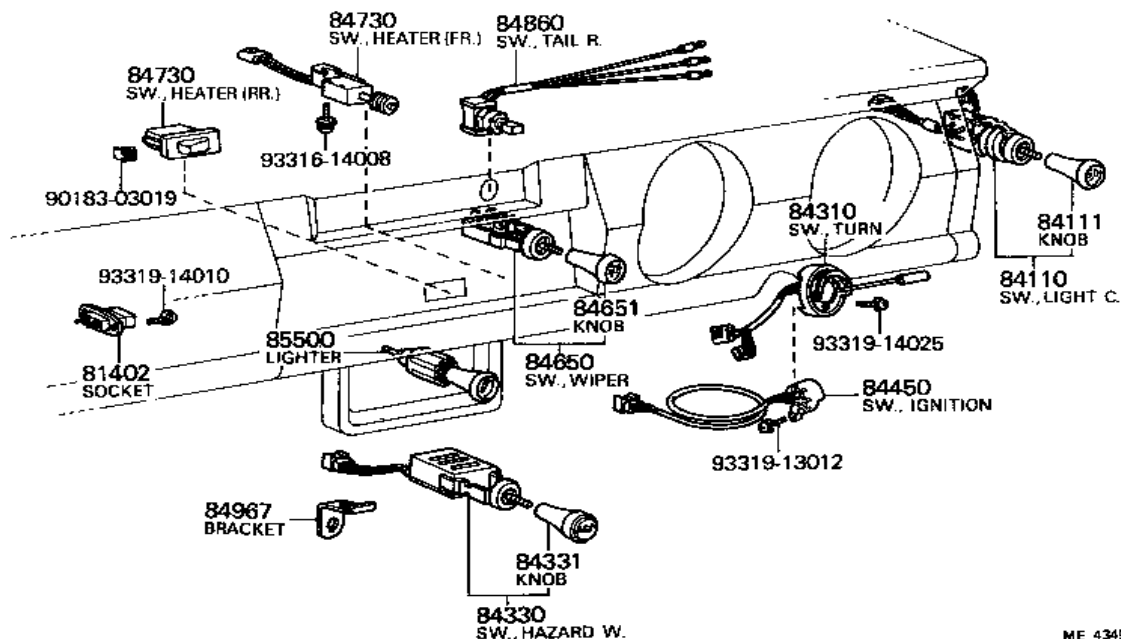

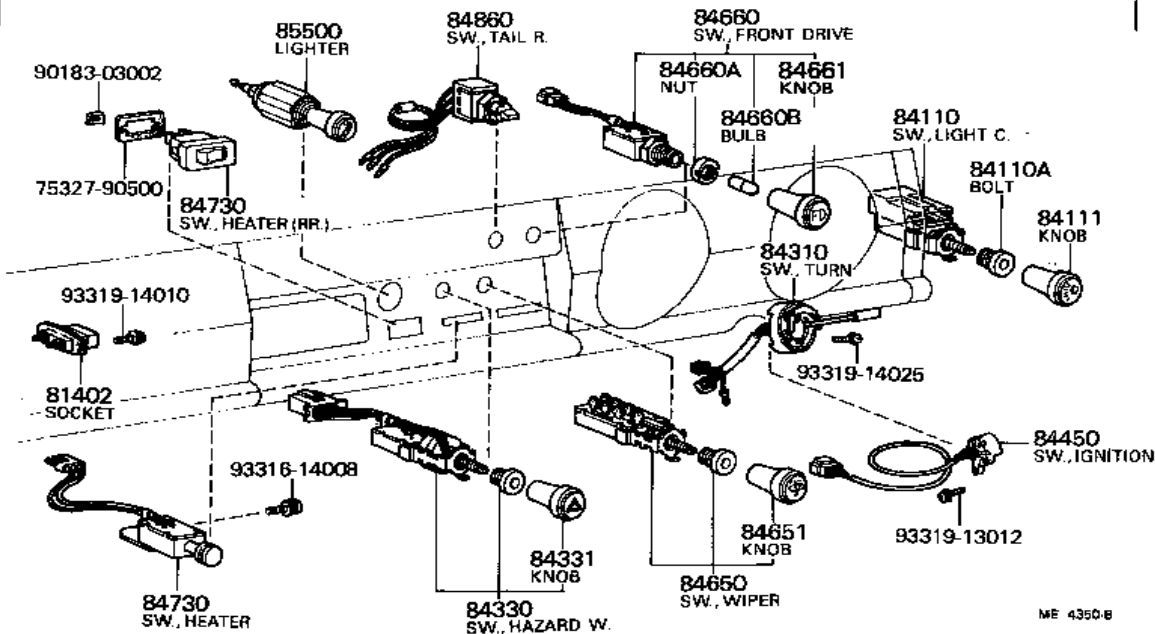
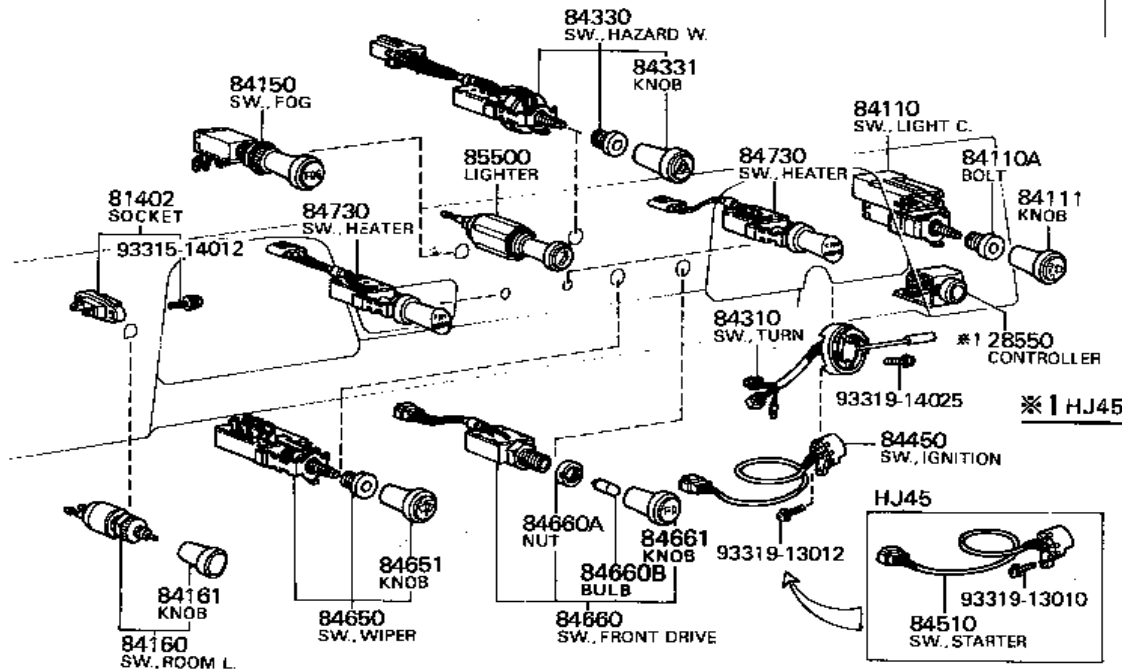

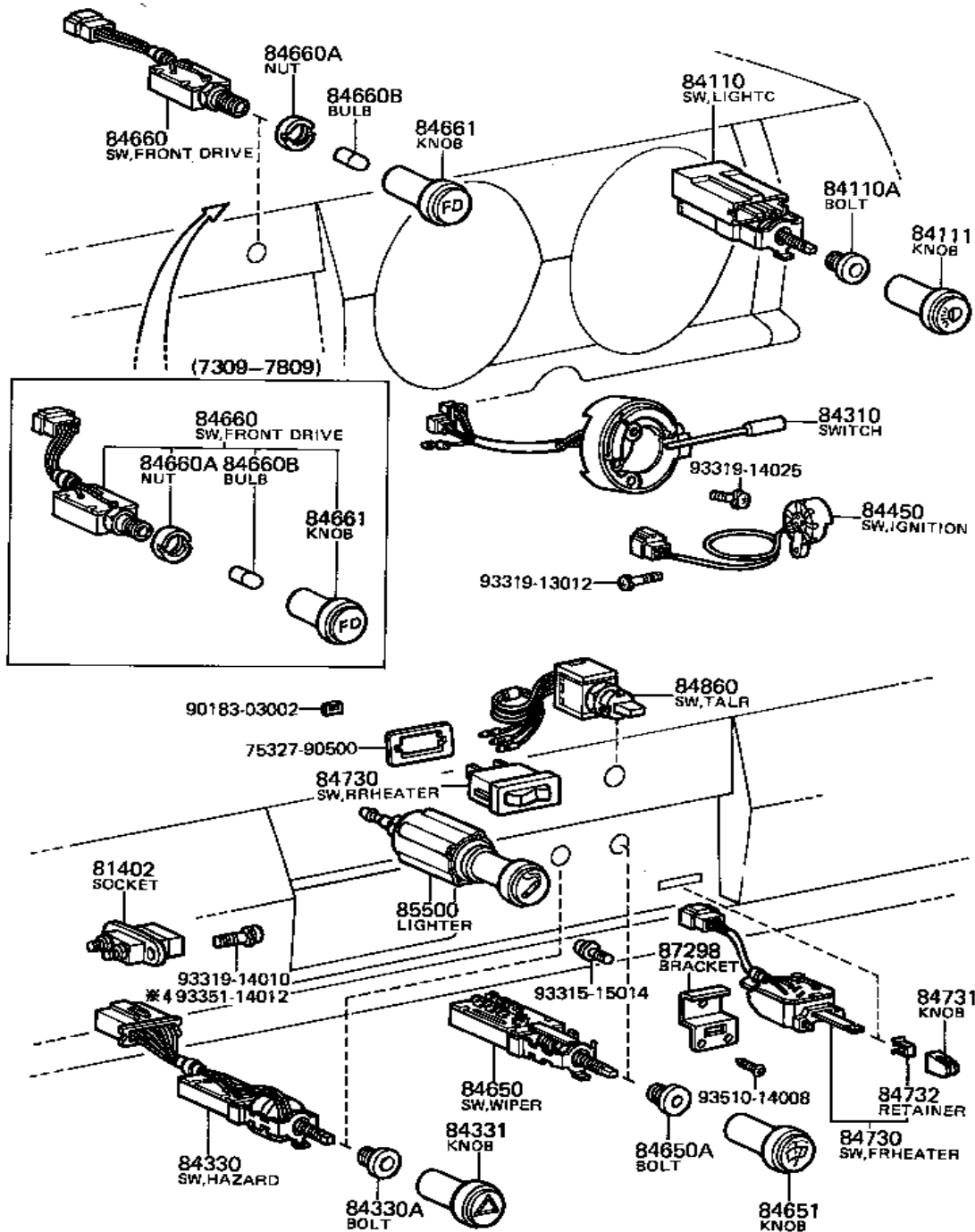

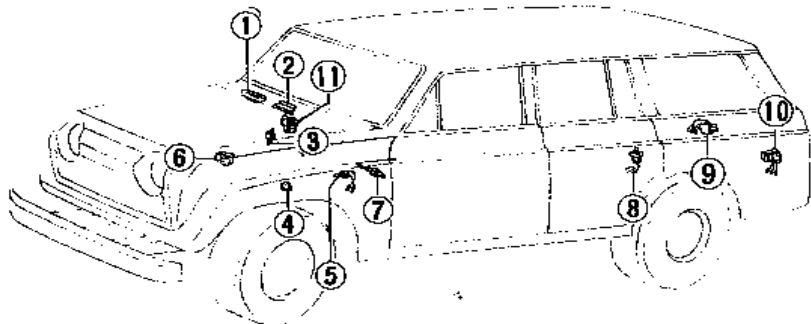

(6903-7109)

① (7109)

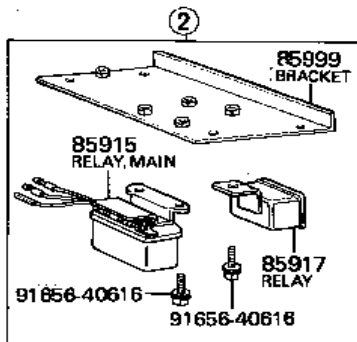
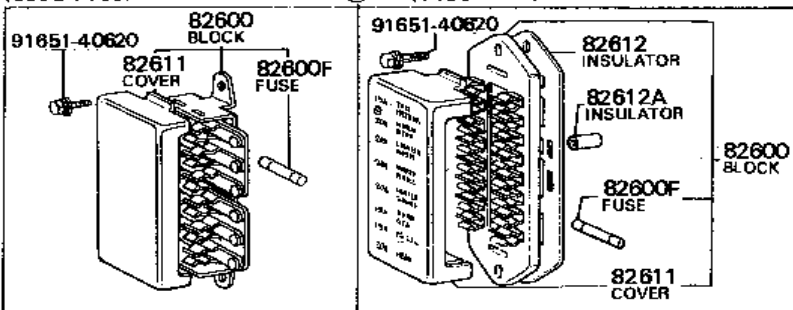

③

④

⑤

⑥

⑦

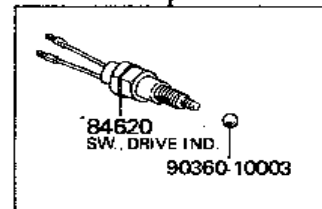
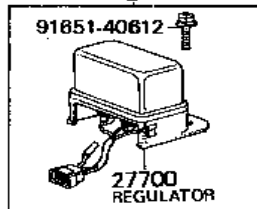
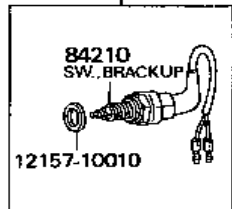
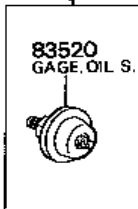

⑧

⑨

⑩

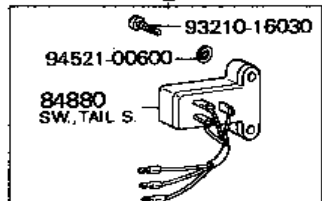
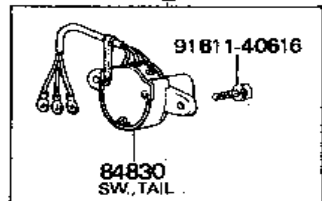
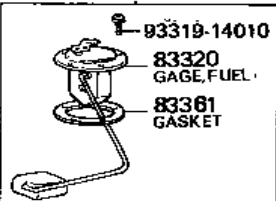

⑪

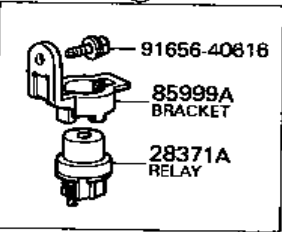

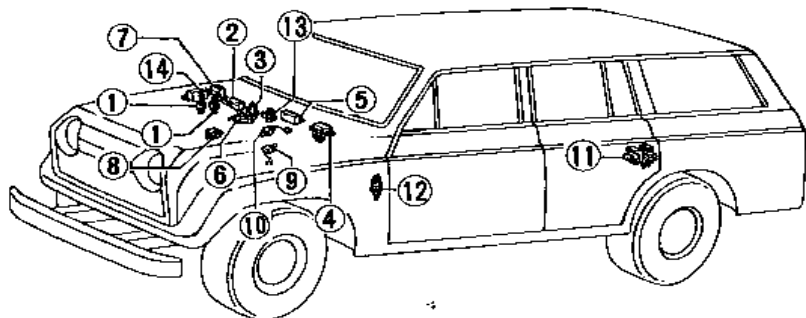

L/Hazard Switch

W/Hazard Switch

①

83540
SW, BRAKE W.



②

91656-40616

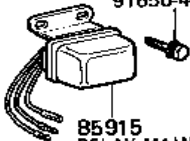

85915
RELAY, MAIN S.

③

81980
FLASHER



91656-40616

③

81980
FLASHER

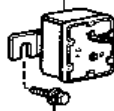

91656-40616

④ (7309-7610)

91651-40614

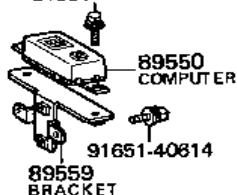

89550
COMPUTER

91651-40614

89559
BRACKET

⑤

91651-40616

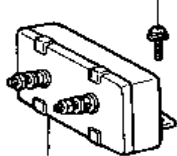

82650
BRAKER

⑥

85440
SOLENOID

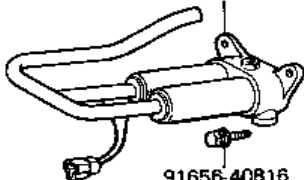

91656-40816

⑦

89550
COMPUTER

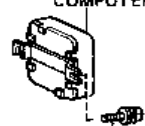

91651-40612

⑧

84210
SW, BACK UP

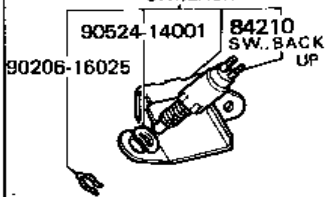

90206-16025

90524-14001

84210
SW, BACK UP

⑨

94120-40800

84380
SW, BRAKE W.

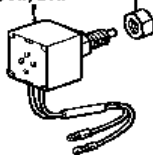

⑩

84340
SW, STOPL.



94120-41000

⑪

82954
BRACKET

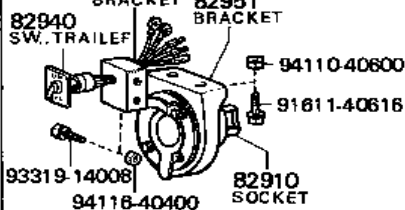

82940
SW, TRAILER

82951
BRACKET

94110-40600

91611-40616

93319-14008

94116-40400

82910
SOCKET

⑫

84220
SW, TRANSFER



⑬

81981
FLASHER



91656-40612

⑭

91656-40616



86530
RELAY, HORN

テール ゲート レギュレータ モータ
Tail Gate Regulator Motor

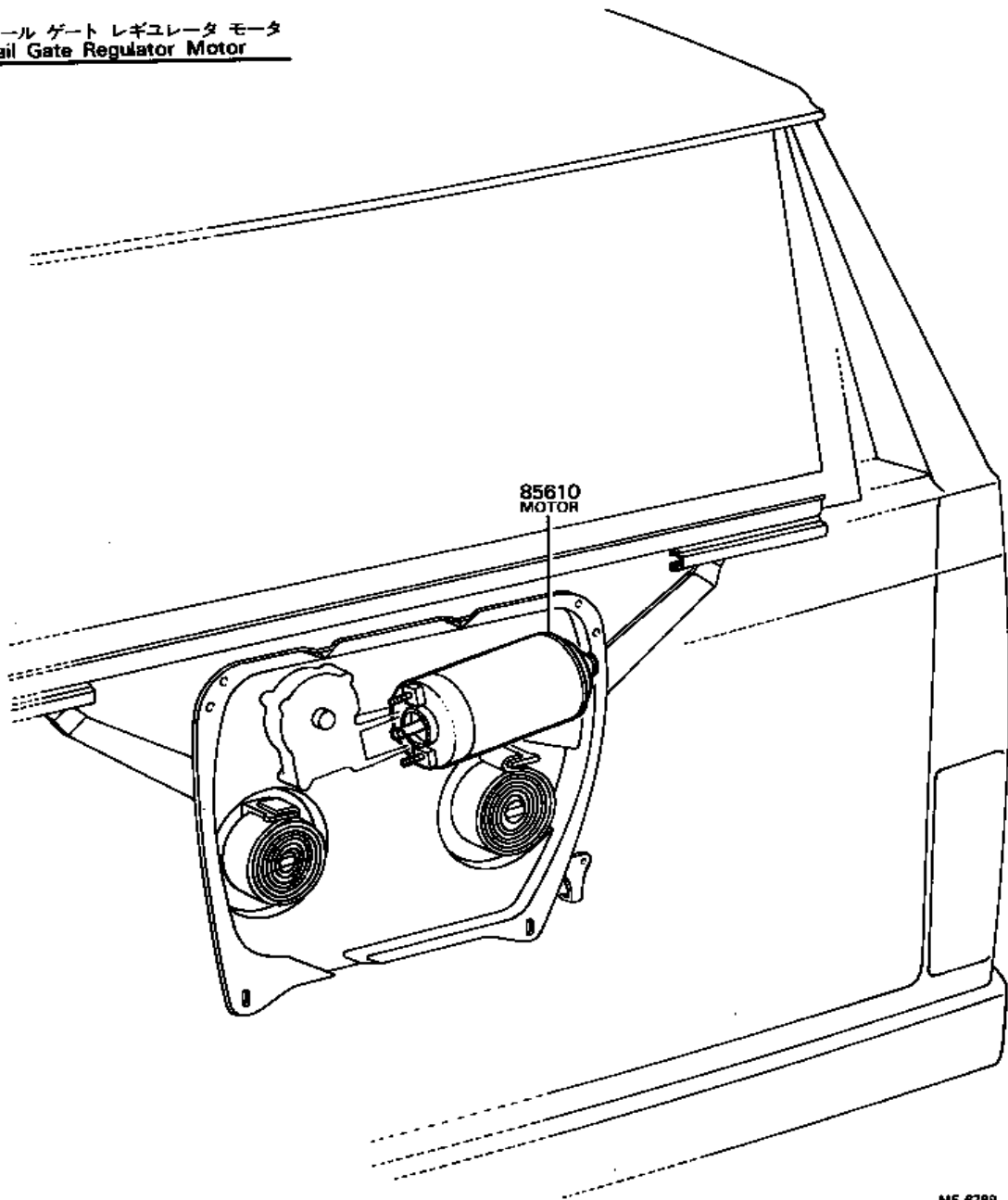

86011
RADIO & SETTING PARTS SET

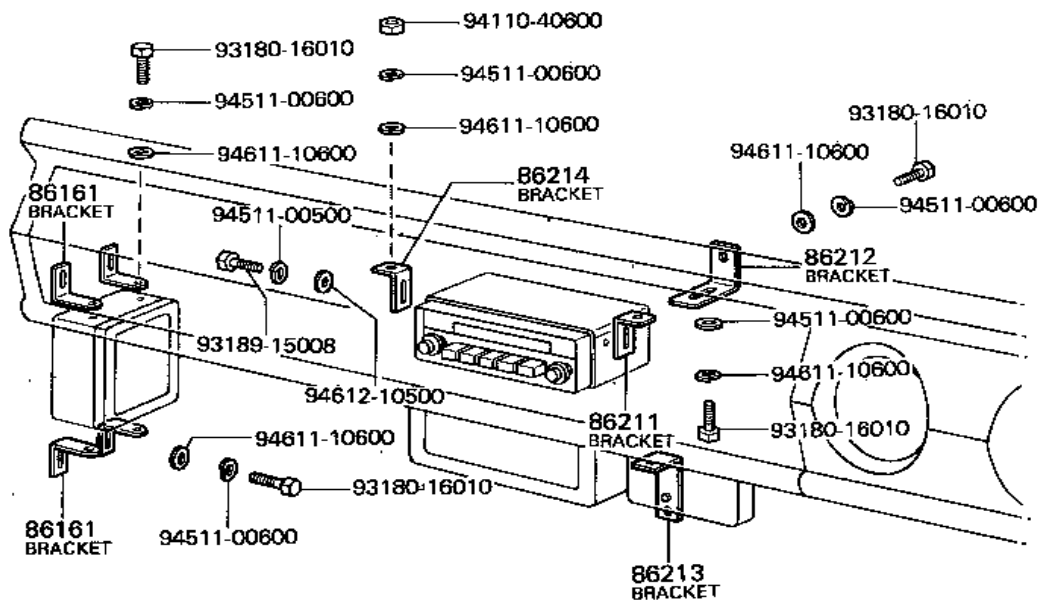
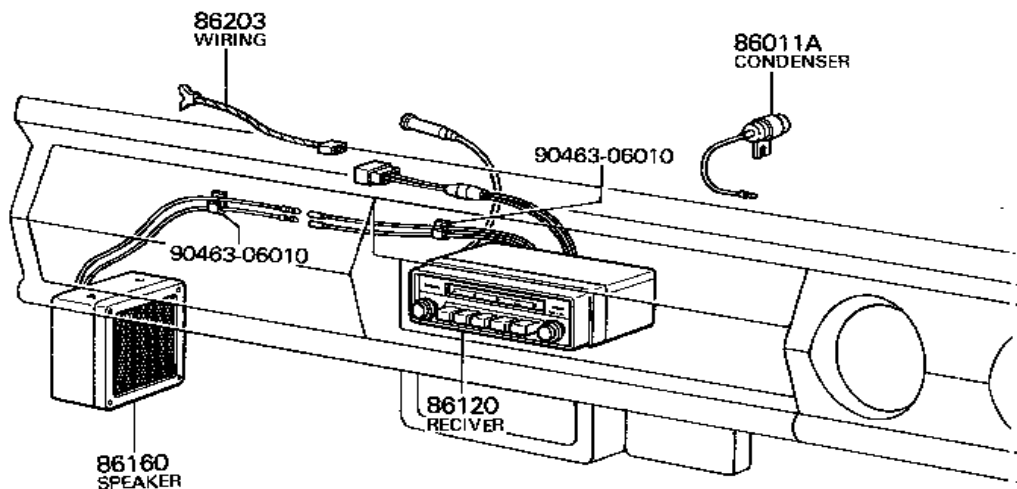

87100
HEATER & ACCESSORY

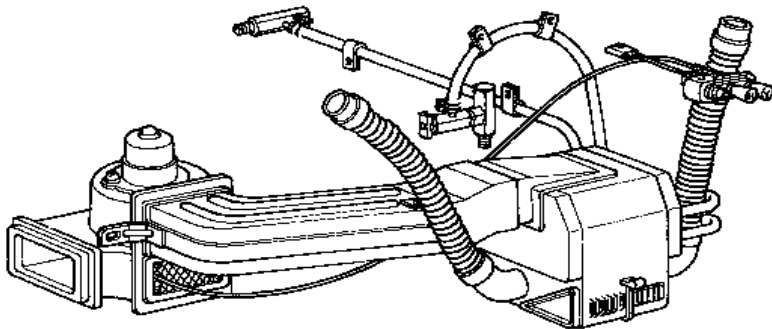

87200
HEATER & ACCESSORY

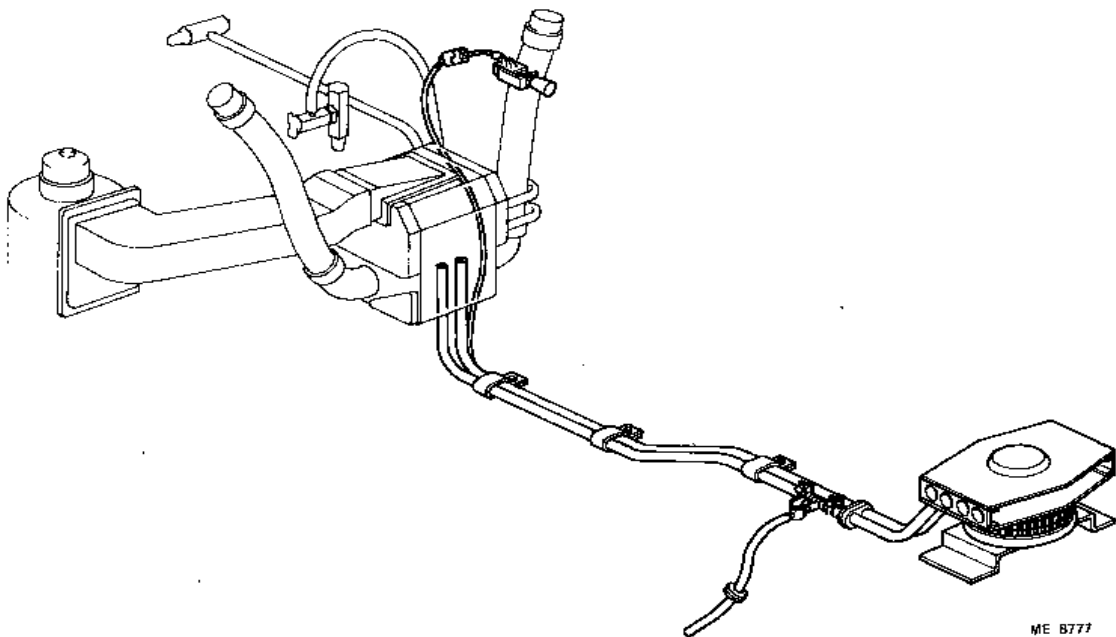

87100
HEATER & ACCESSORY ASSY

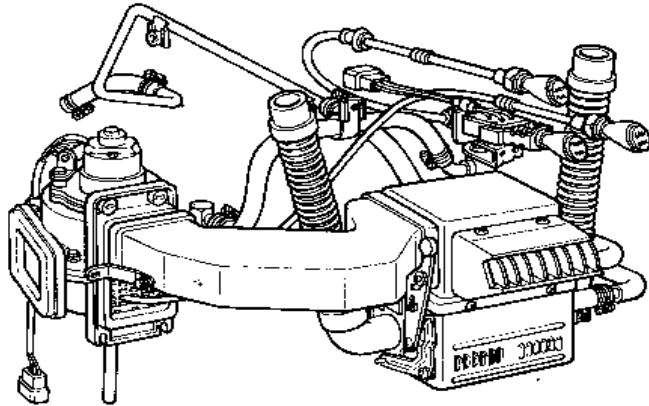

リヤヒータ付
W/Rear Heater

87100
HEATER & ACCESSORY ASSY (7309-7901)

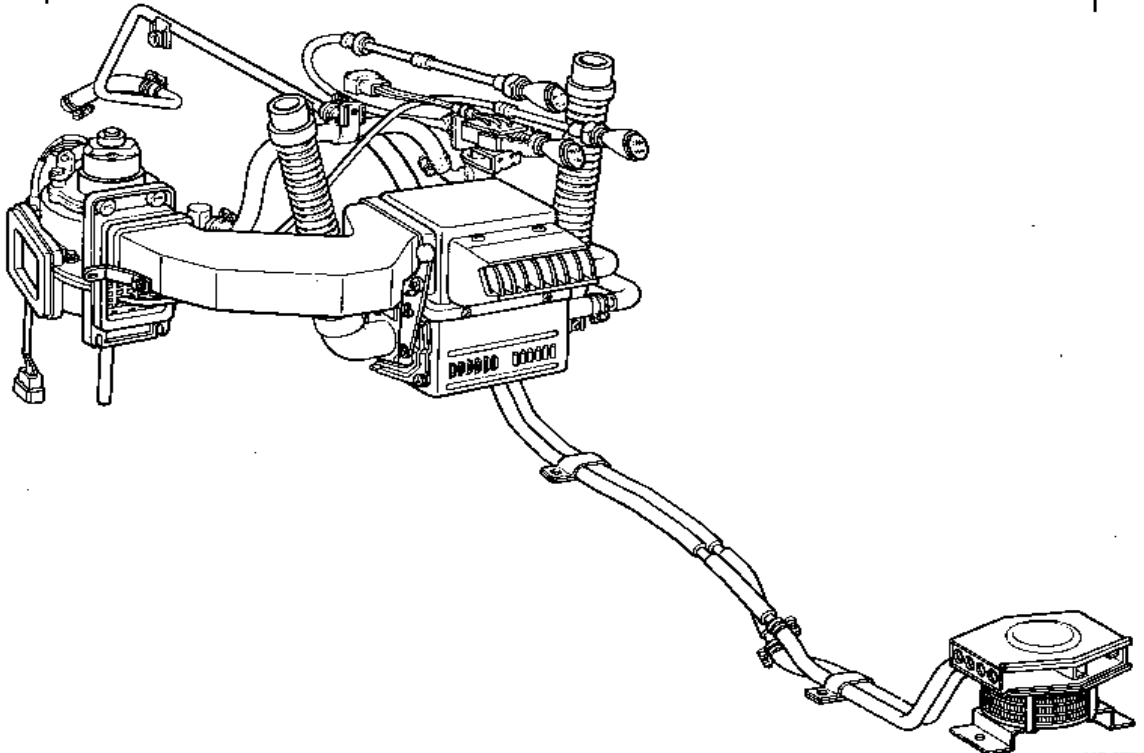

(7010-7309).

88300
COOLER ASSY

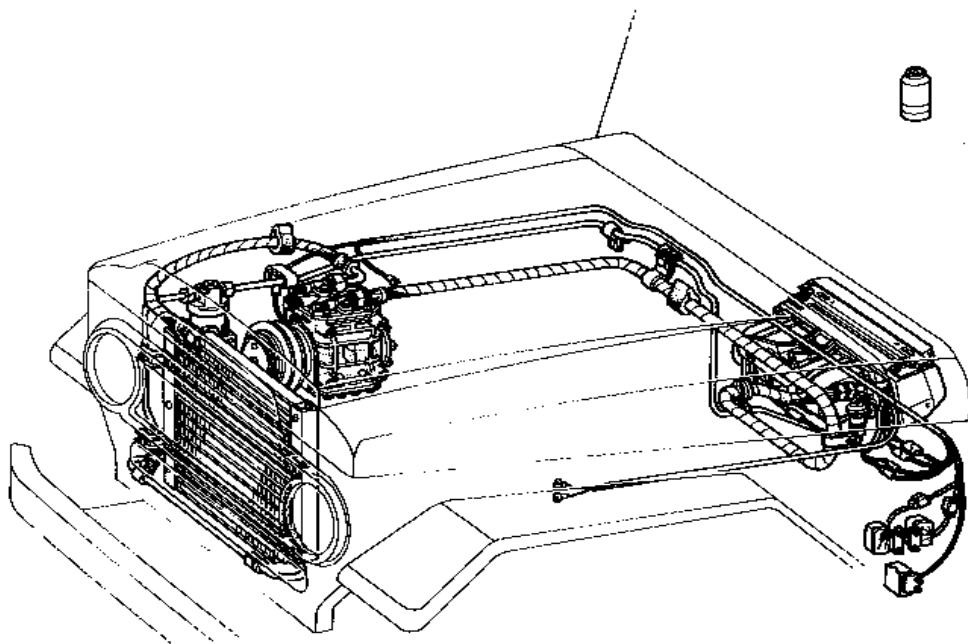

(7309-)

88300
COOLER ASSY

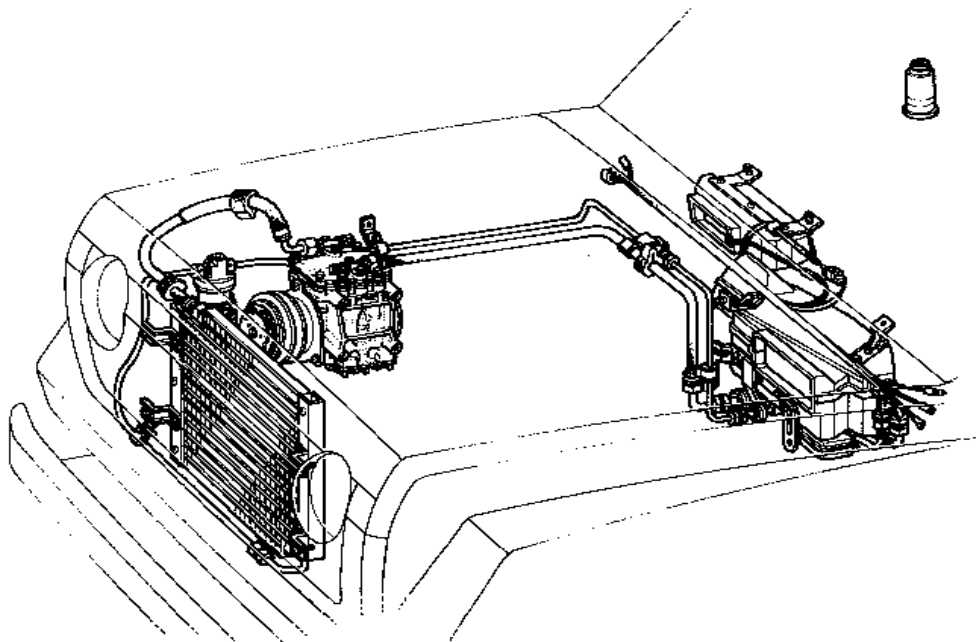

88900
VENTILATOR & ACCESSORY

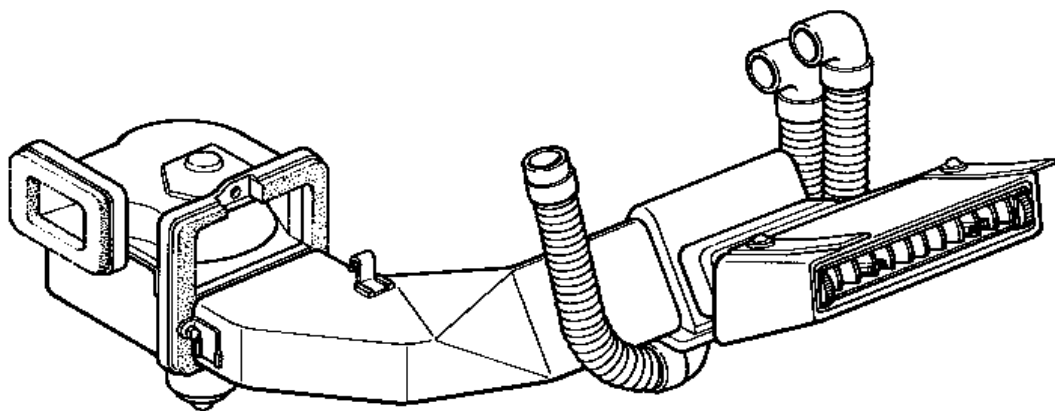
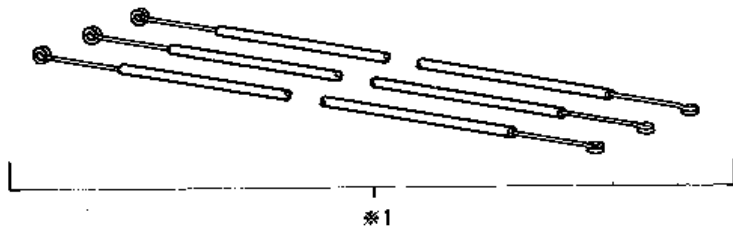

*1 (7405-)

88900

Not included in VENTILATOR & ACCESSORY

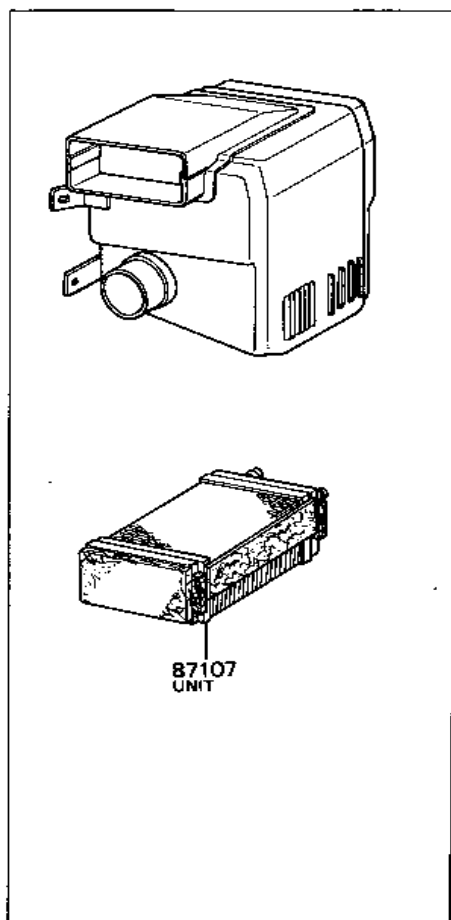
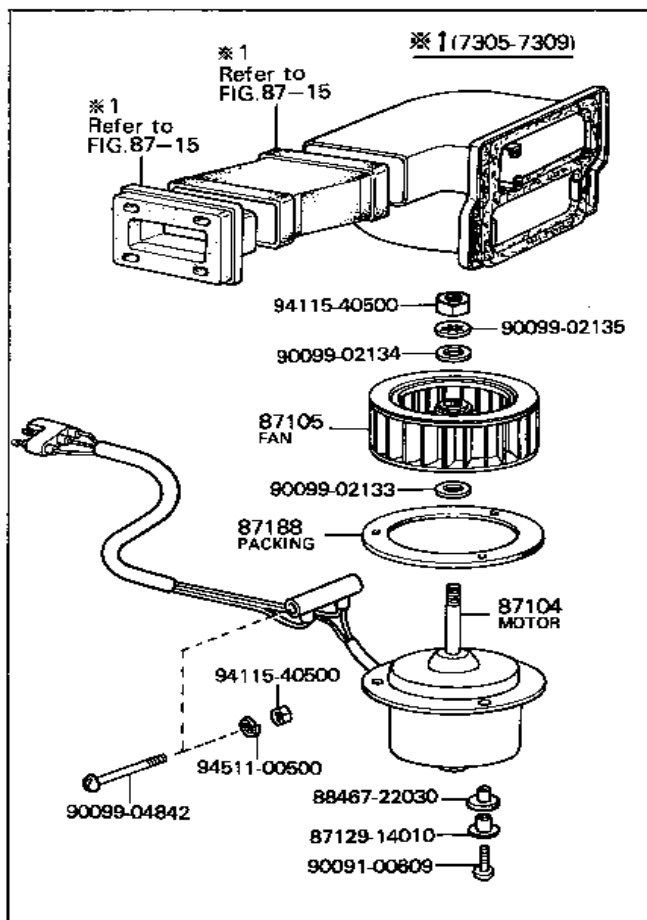
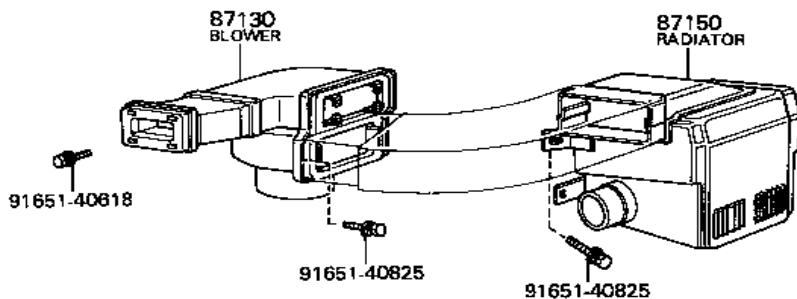

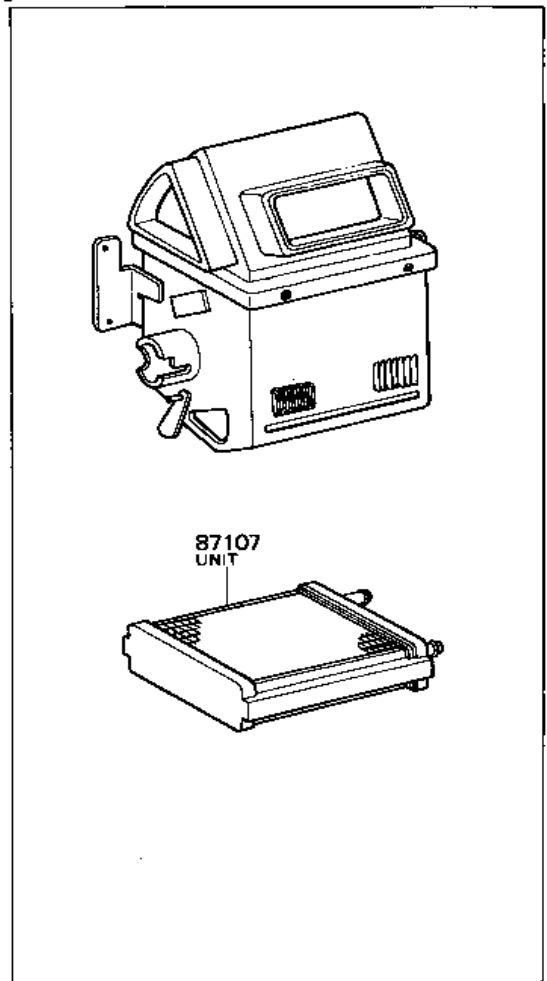
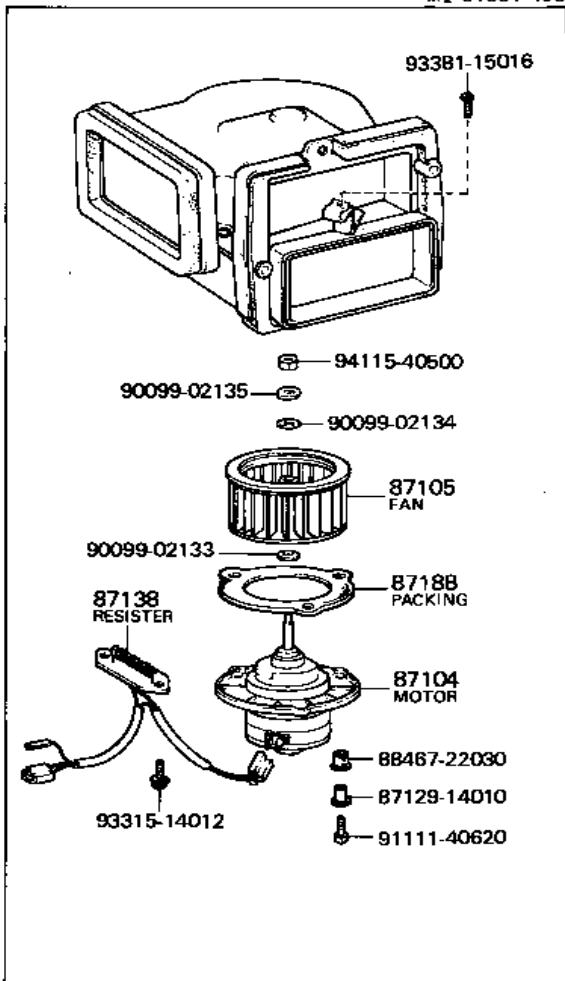
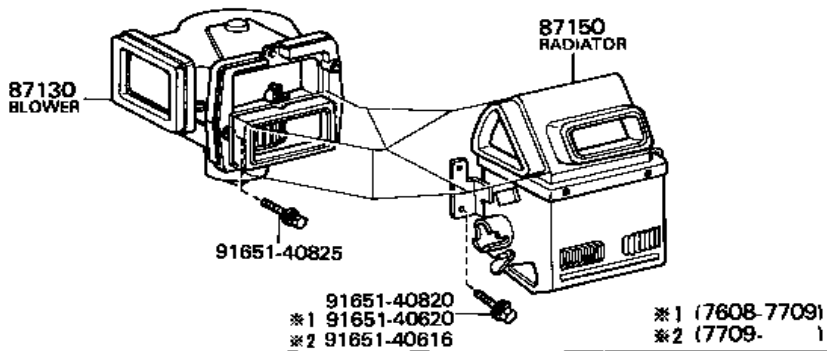

Rear Heater

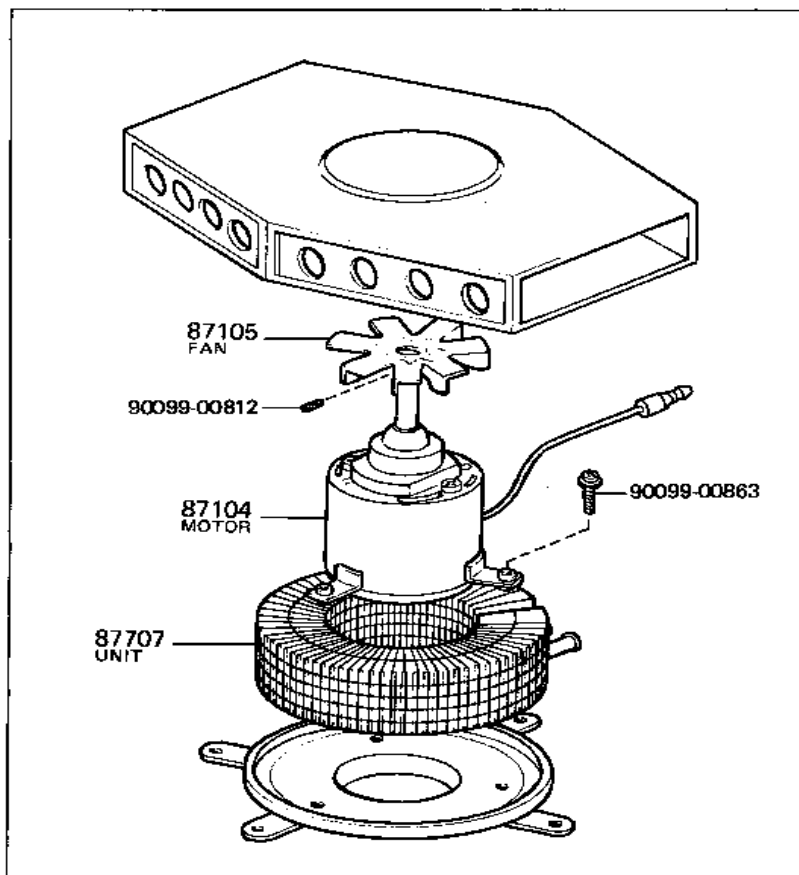
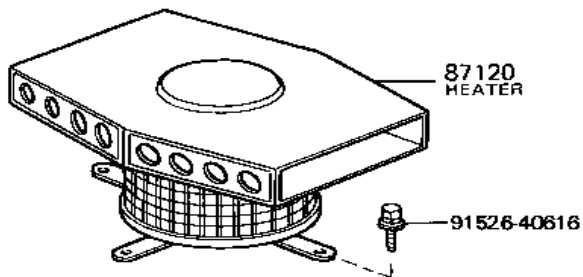

Boost Ventilator

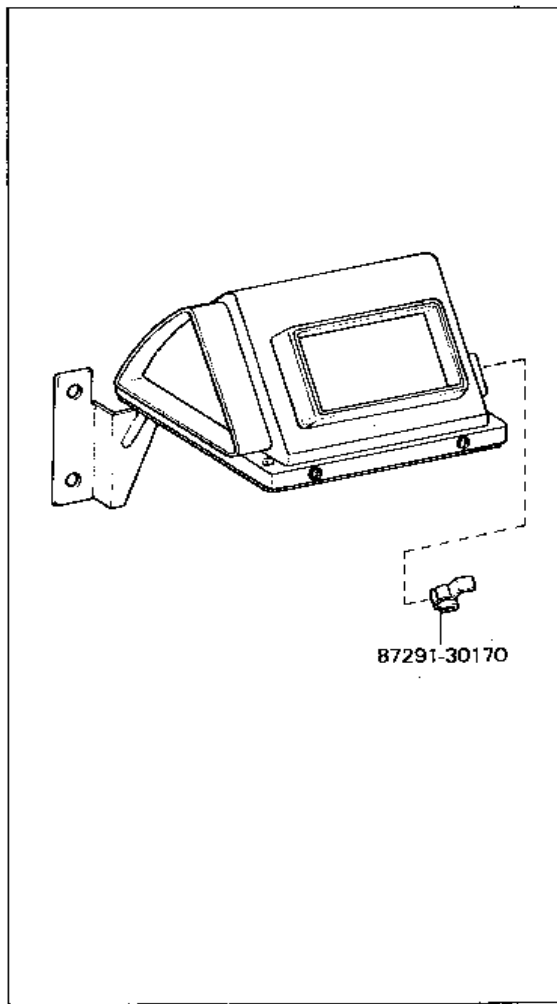
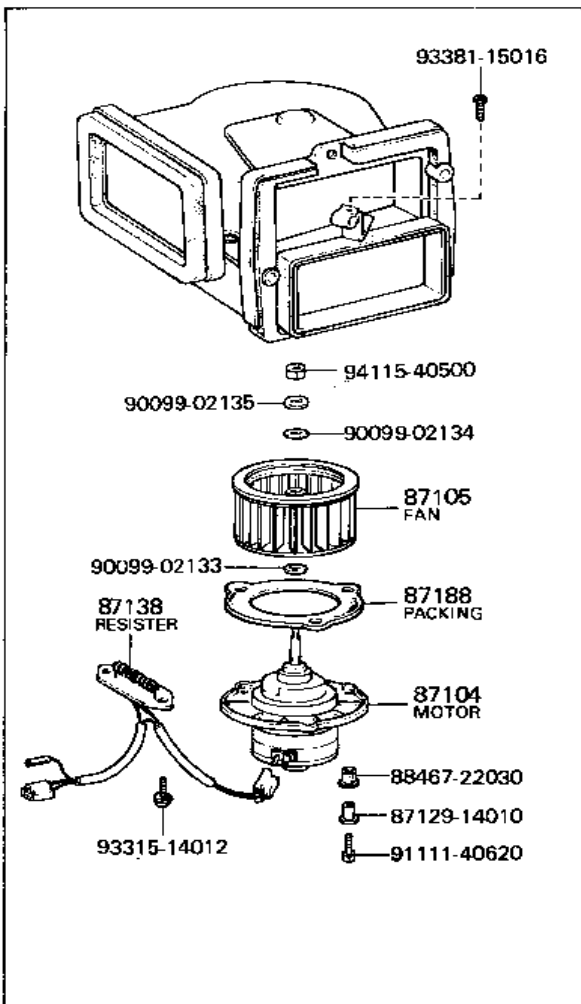
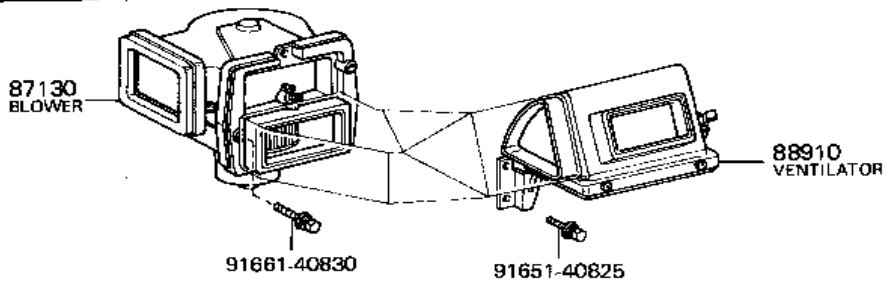

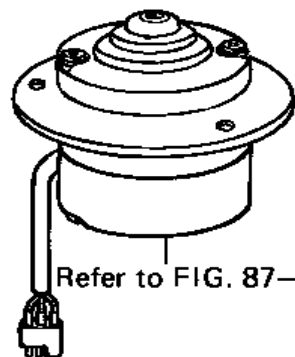

90092-20582

94511-00500

87184
HOUSING

90092-20582

94511-00500

87183
HOLDER

87183A
BUSH

94611-10500

90099-01230

90099-01015 (t=0.5)

90099-01017 (t=0.3)

90093-30801 (t=0.2)

90093-30802 (t=0.1)

90099-01230

87182
STATOR

87181
ARMATURE

90093-30801 (t=0.2)

90093-30802 (t=0.1)

90099-01015 (t=0.5)

90099-01017 (t=0.3)

90099-01230

87185
HOUSING

90099-04804

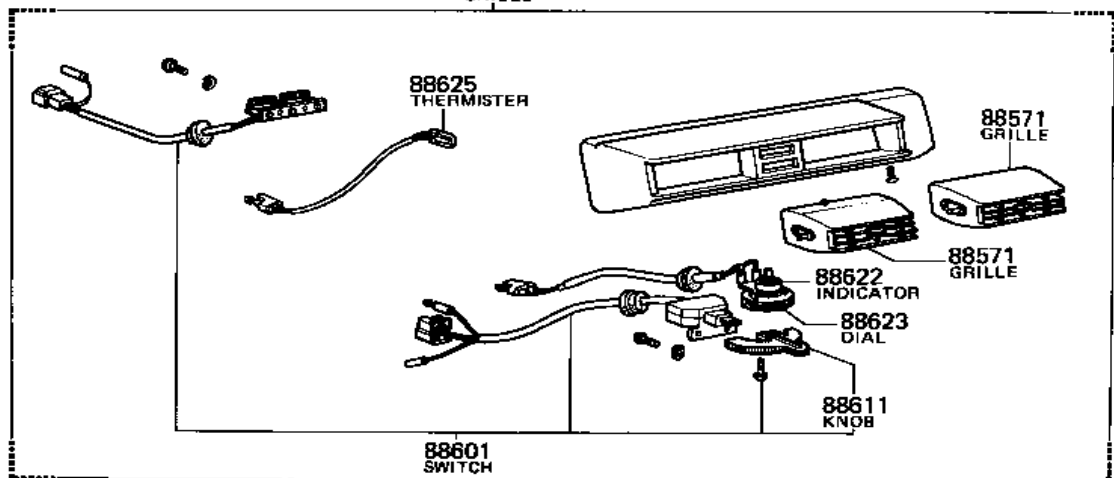
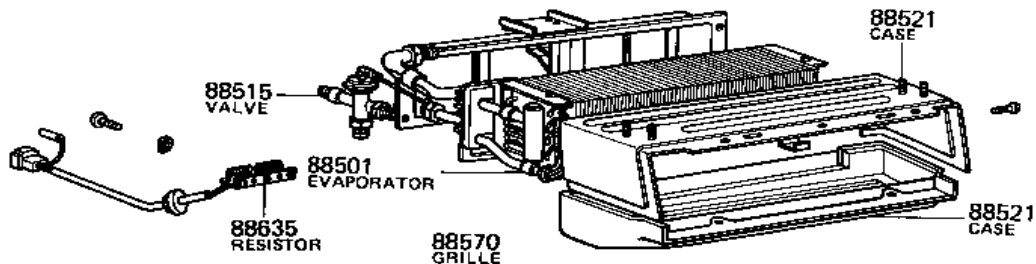
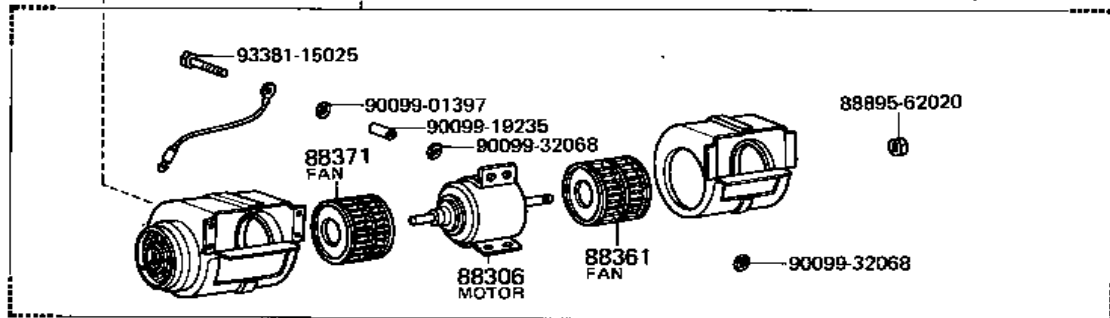
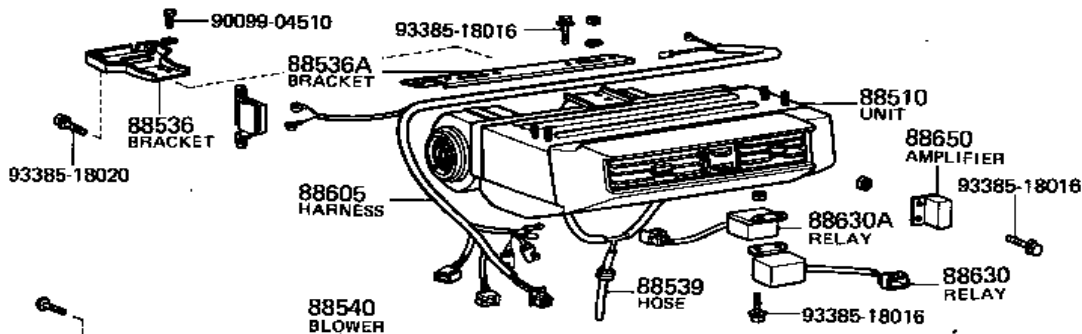

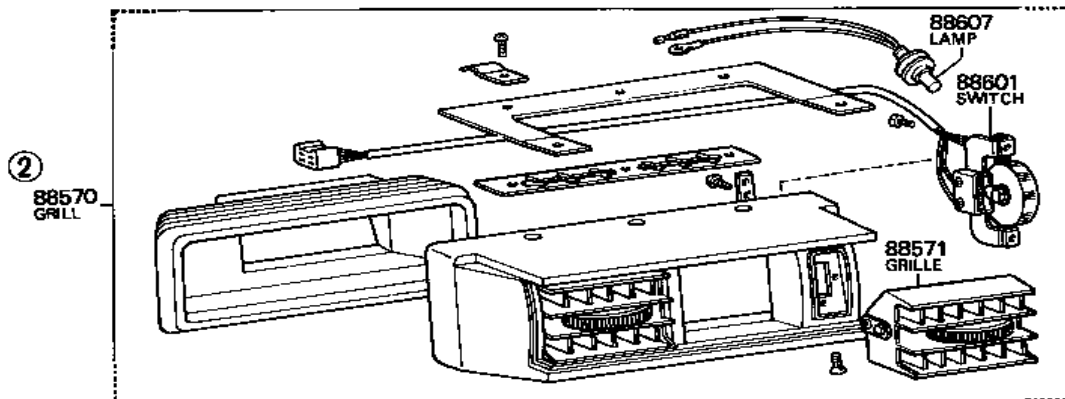
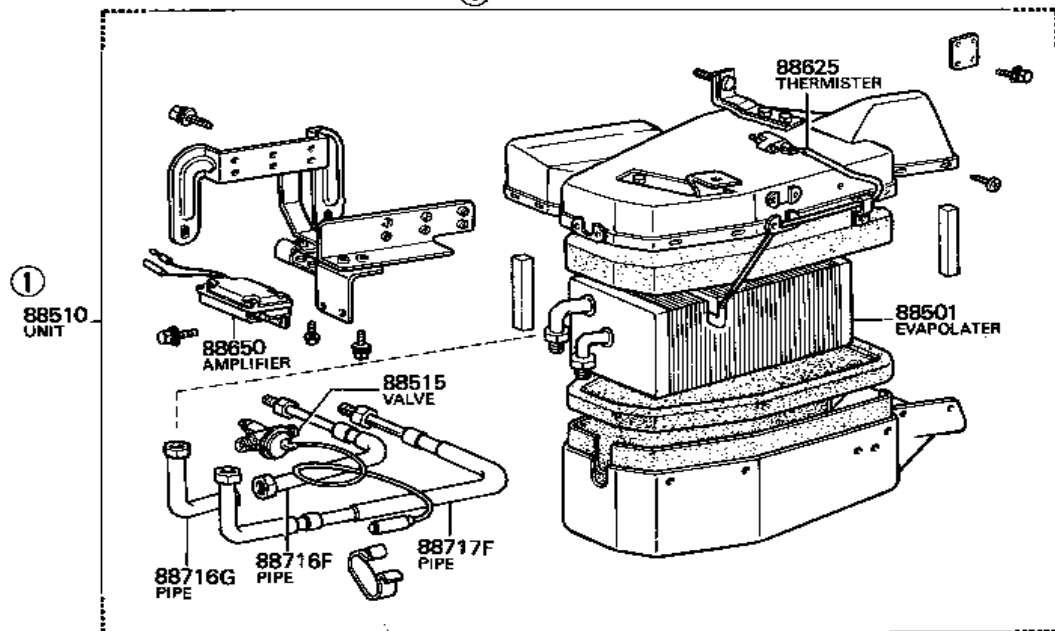
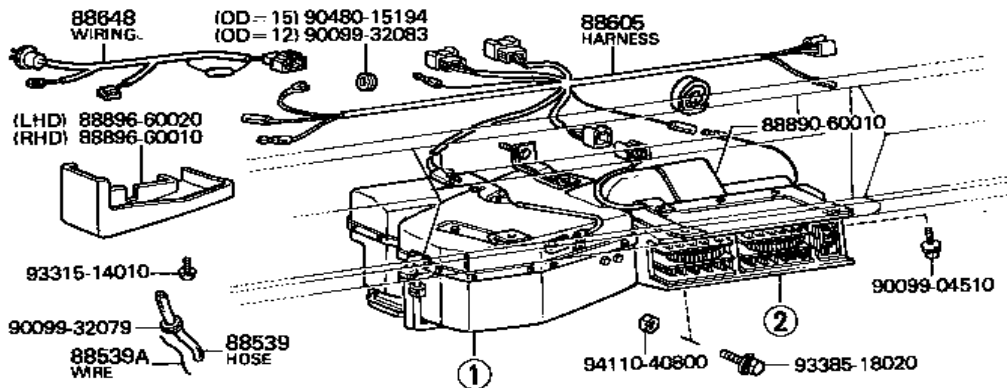

93219-14008

95381-01208

94611-10300

55910 CONTROL

(-7209)

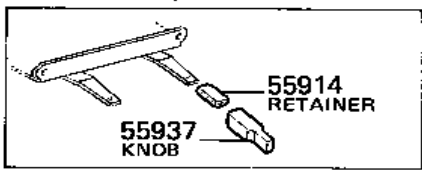

93315-14010

* 91651-40816

* 87202 DUCT

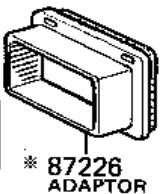

55932 GUIDE

55937 KNOB

55907 CABLE

94611-10300

95381-01208

55925-30010

55905 CABLE

87294 NET

* (-7305)

90159-40027

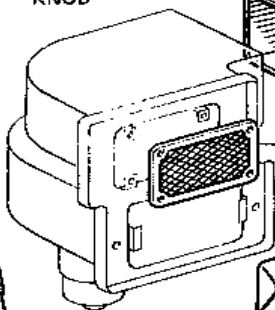

87201 DUCT

55925-30010

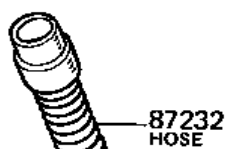
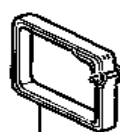

87232 HOSE

87232 HOSE

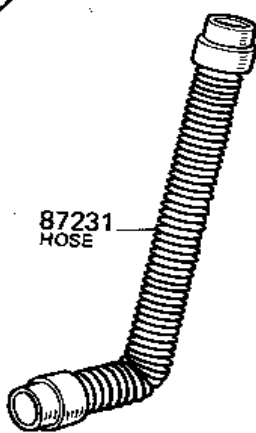
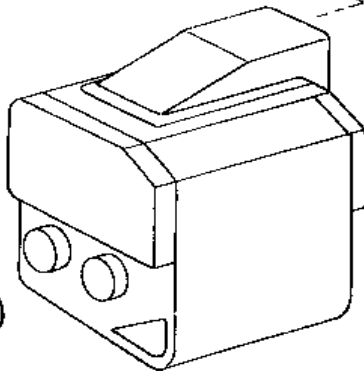

90461-08337

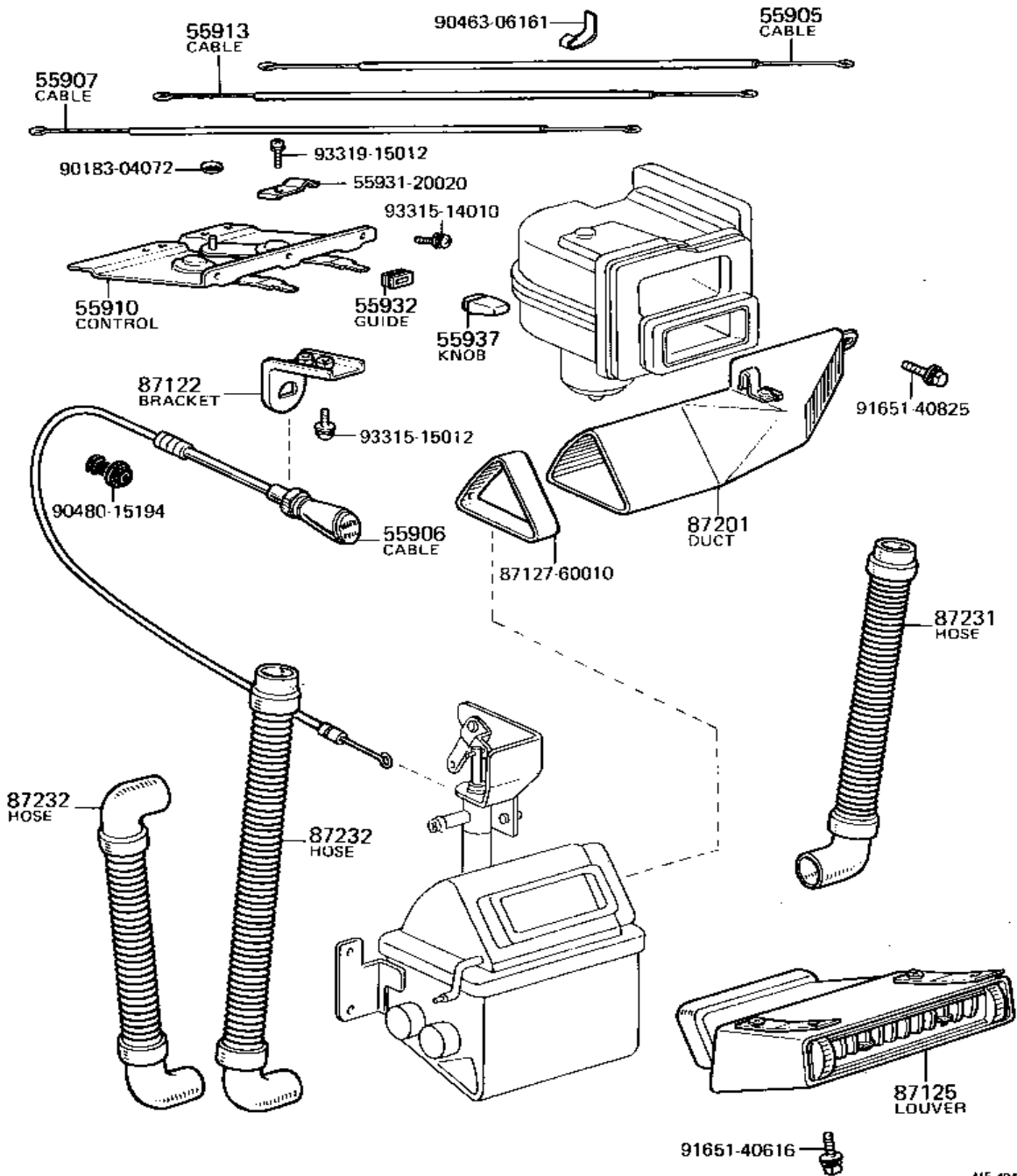

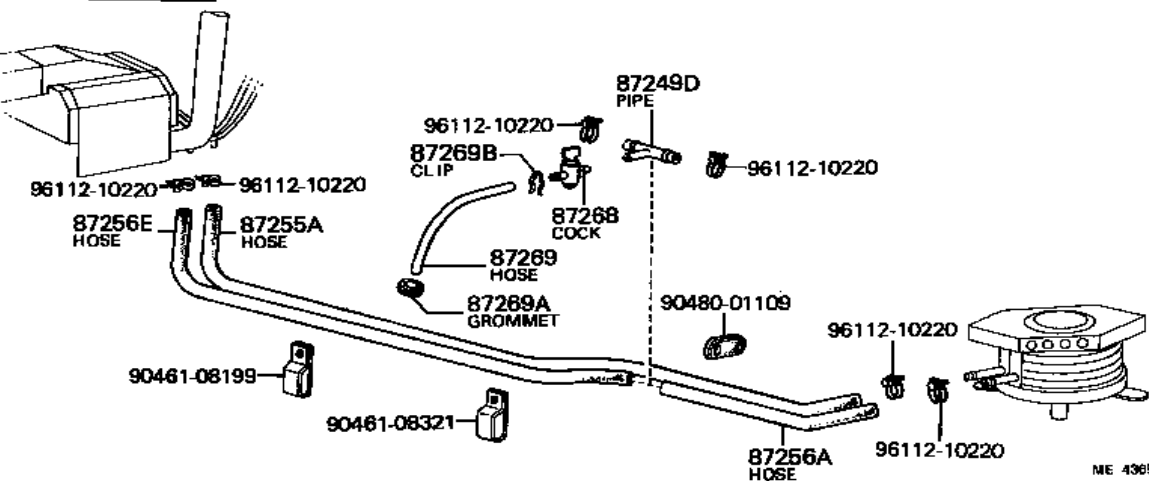
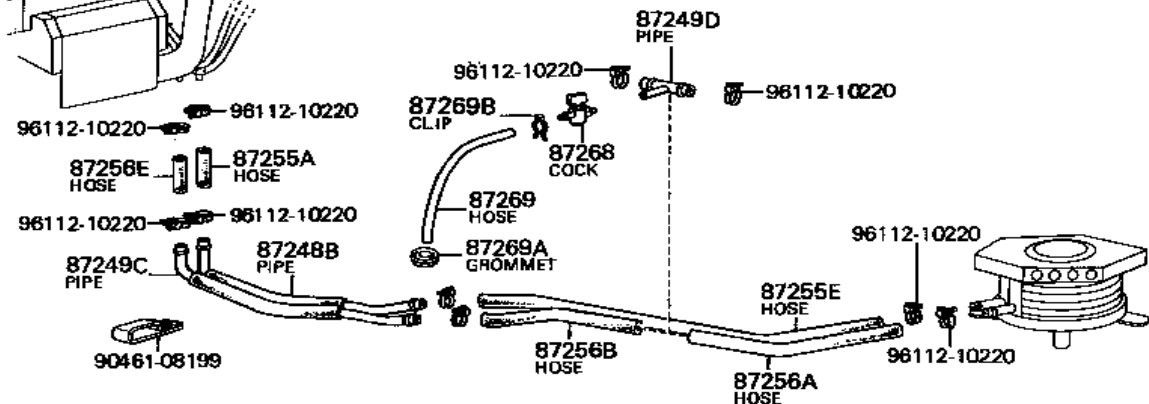
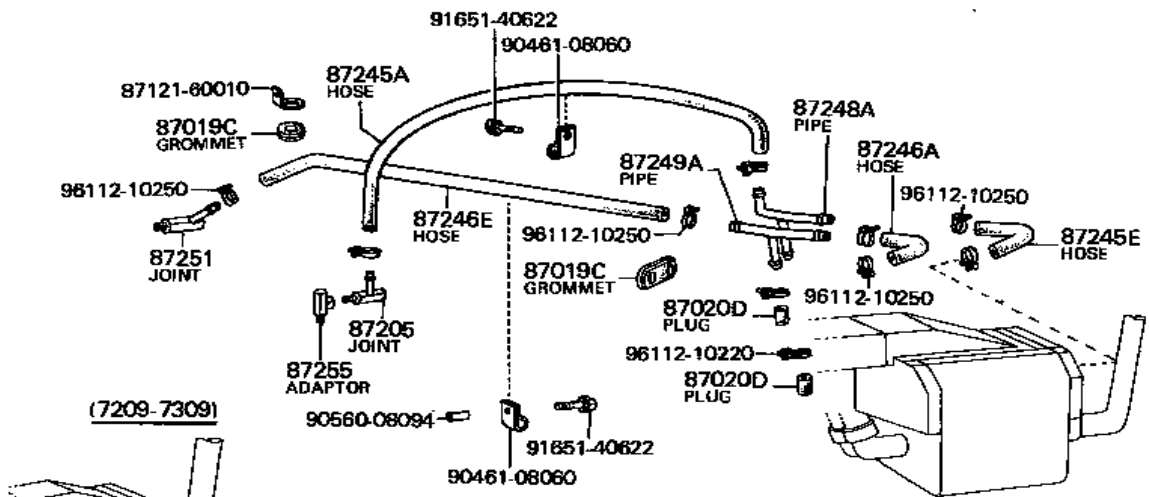

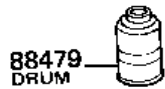

88714-14020

94110-40600

93385-16025

93385-16012

88718-60010 *3

88718-60030 *4

88385-16012

94110-40800

94110-40600

93385-16012

88718-60010 *3

88718-60030 *4

88713-60010

88711
HOSE

88470
RECEIVER

88716E
PIPE

94110-40600

90099-21012 *1

90099-21011 *2

90099-05201

90099-32060

88472
BRACKET

93385-18016

88712
HOSE

90099-21010

88716A
PIPE

88472A
BRACKET

88714-14020

93385-16012

*3 88718-60020

*4 88718-60040

90099-05201

94110-40600

93385-16012

88713-60020

94110-40600

93385-16016

88460
CONDENSER

*1 (-7309)

*2 (7309-)

*3 (-7501)

*4 (7501-)

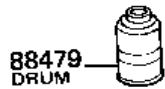

88714-14020

94110-40600

93385-16025

93385-16012

88718-60010 *3

88718-60030 *4

88385-16012

94110-40800

94110-40600

93385-16012

88718-60010 *3

88718-60030 *4

88713-60010

88711
HOSE

88470
RECEIVER

88716E
PIPE

94110-40600

90099-21012 *1

90099-21011 *2

90099-05201

90099-32060

88472
BRACKET

93385-18016

88712
HOSE

90099-21010

88716A
PIPE

88472A
BRACKET

88714-14020

93385-16012

*3 88718-60020

*4 88718-60040

90099-05201

94110-40600

93385-16012

88713-60020

94110-40600

93385-16016

88460
CONDENSER

*1 (-7309)

*2 (7309-)

*3 (-7501)

*4 (7501-)

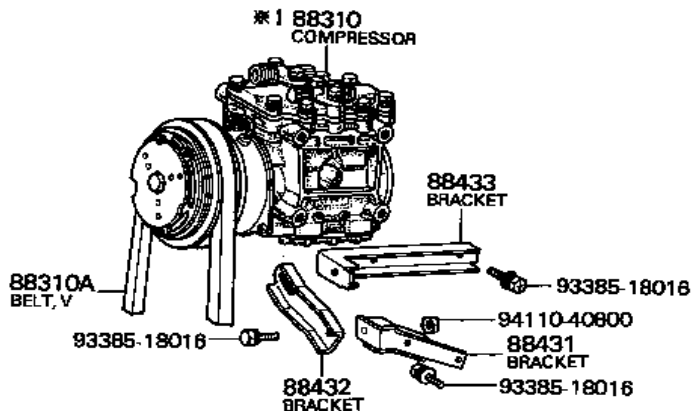

(7109)

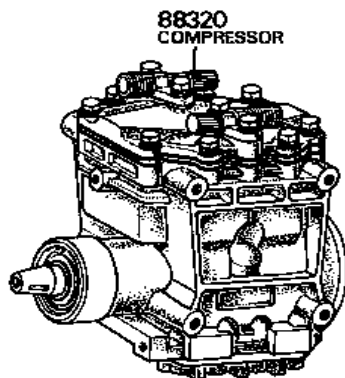
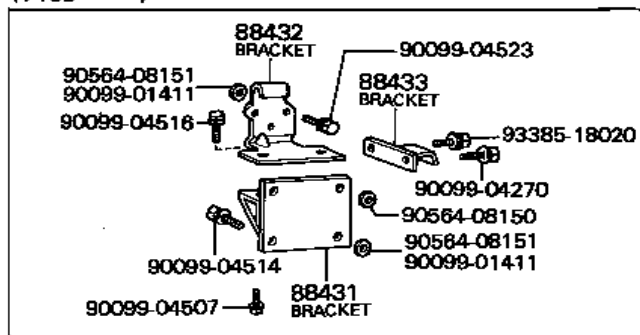

*1 (7010-7501)
 *2 (7010-7211)

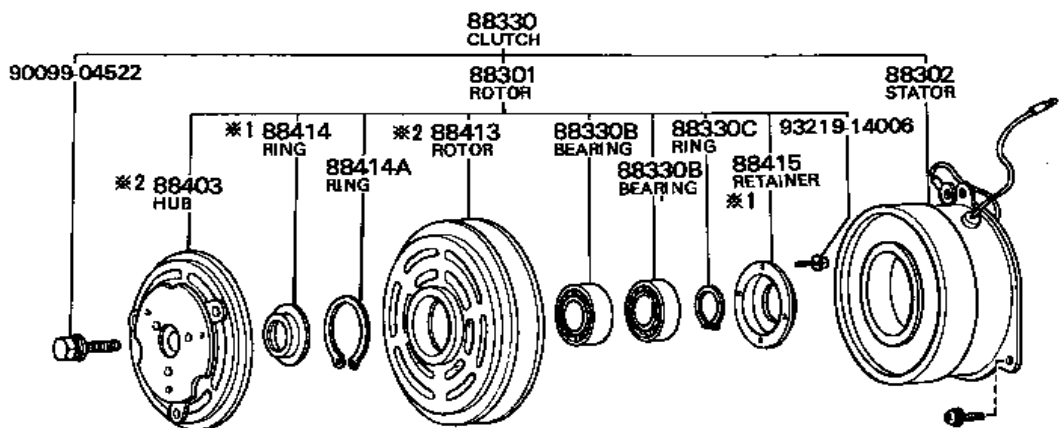

ME 4370-C

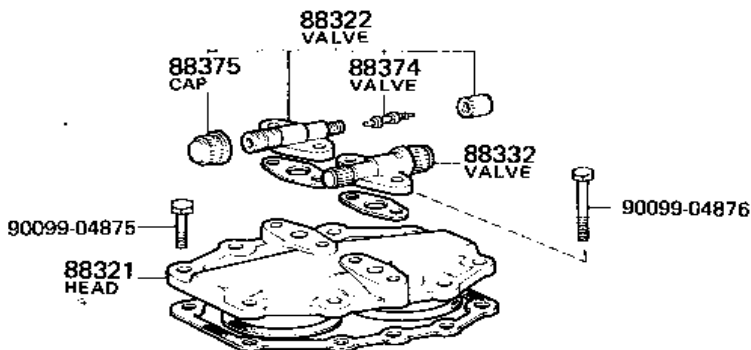
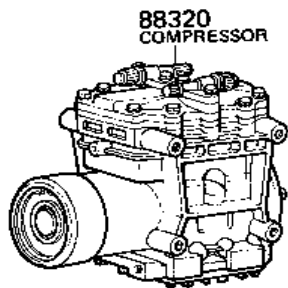

88320K
GASKET KIT

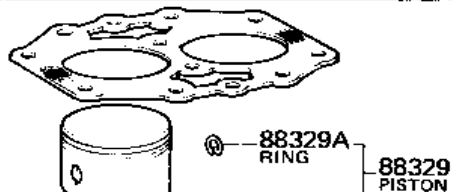
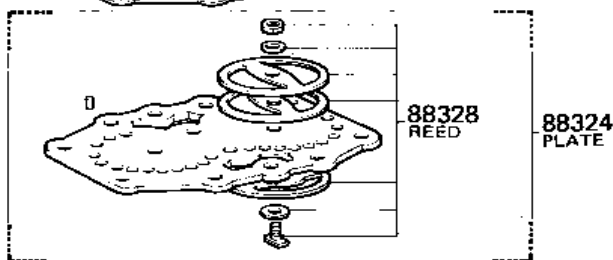
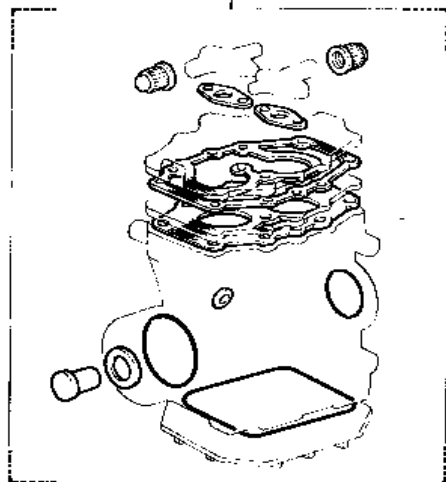

88325B
PLUG

88364
BEARING

90099-04877

88308
PUMP

88326 (REAR)
PLATE

88360
SEAL

88362
PLATE

88316
CRANKSHAFT

88326 (LOWER)
PLATE

90099-04878

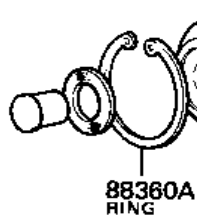

88316A
BEARING

88316C
KEY

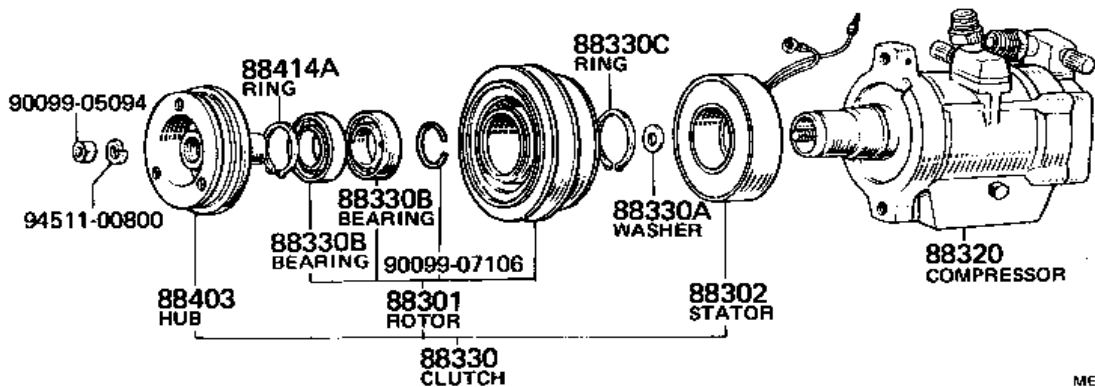
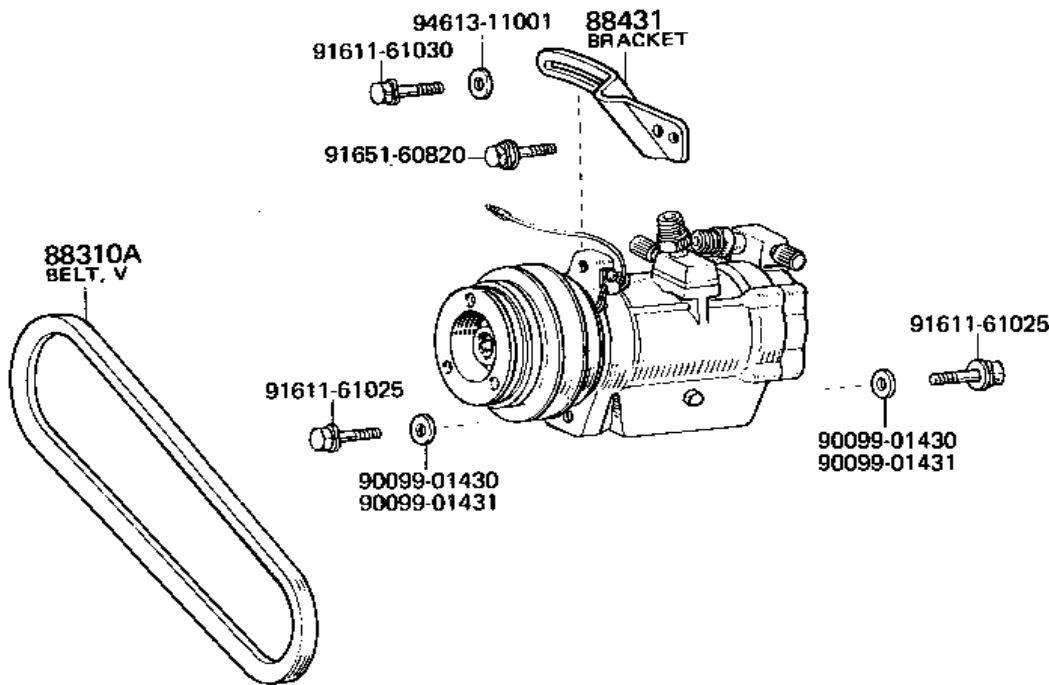

90099-04255
88322 VALVE

88320K GASKET KIT

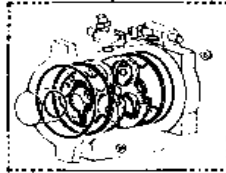
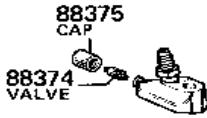
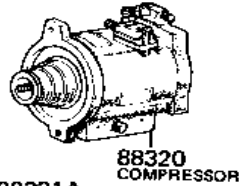

88321A PLATE

88321B REED

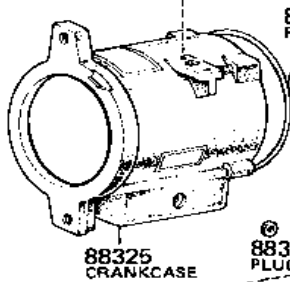

88360A RING

88362 PLATE

88360B SEAL

88360 SEAL

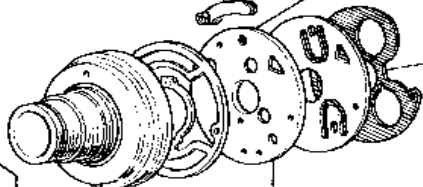

88321C REED

88321 HEAD

88339 PLUG

90099-04255

88332 VALVE

88304 CYLINDER

90099-08057

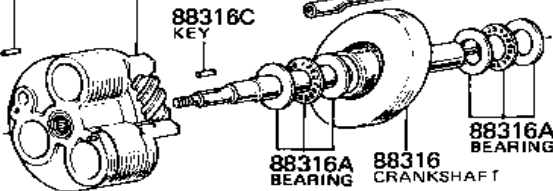
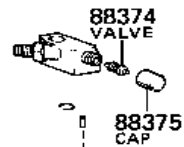

88321D VALVE

88338 TUBE

88321C REED

88329 PISTON

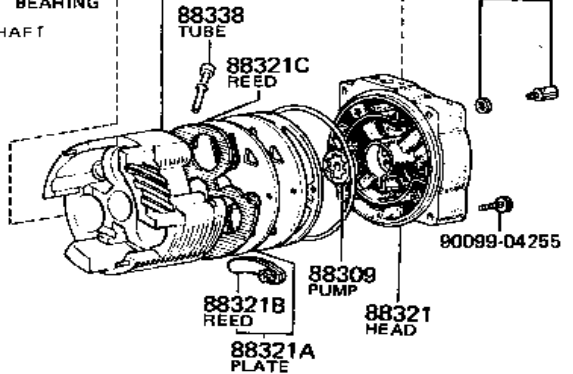

90099-04255

88321B REED

88321A PLATE

